

Ø  
 Ö  
 Ô  
 Ó  
 OE

Ø  
 Ö  
 Ô  
 Ó  
 OE

%<C@9G5B8-BH9F: 5798-A 9B G-CBGD9F A @8H@&(' \$, "  
 &"A 5H956@9K #k: 7CBB97HCFGA 5B1: 57H F98 D9F A @8H@&(' \$, "  
 ' "89G= B 98 HC 69 @5G9F K 9@898 HC 5 \* \$\$\$! G9F -9G5@ A -B1 A <C1 GB; "  
 ("<9FA 9H7 @95? F5H9. @9GGH5B CF 9E1 5@HC %L%&! - 77#G97 <95H%5HA 8=: 9F 98H5@DF9GG F97  
 )"9@97HF 75@F9E1 F9A 98HG  
 .....BG @5HCB F9G-GH5B791 A1 GH69: F95H9F Hk5B ) &\$\$A 9 C<A G5H  
 (") \$±%&! "J 87 5H&) 7 -5K 95!" \*(!&%  
 .....8-9@97HF 7 K #k: GH5B8-B; J C@H5; 91 A1 GHG-Ck BC 9J -89B79C: 6F9578CK B CF: @5G-CJ9F  
 .....K <9B GI 6-97H98 HC) \$\$\$J 57 FA G \* \$<nD9F 95!" \*(!&"8I F5HCB C:  
 .....5DD@75HCB G<5@69%G97CB8 A -B A I A "  
 .....7I FF9BHF5HB; . " 5A DGA 5L D9F 7CBH57H"  
 # "A 5H9F -5@G  
 .....K 9@8: @5B; 9 (LLL!G9F -9G5@ A -B1 A "  
 .....7CBH57HG 69FM@A A !7CDD9F "  
 .....BG @5HCFG ?FMC: @9L 79F5A 7"  
 .....<9@75@-B G9F HG. " \$\$\$! G9F -9G GH5-B @9GGH99@  
 ; : -B-G<.  
 .....7CBH57HG 9@97HFC@MH7 B 7?9@D@5H9 -5K 'EE!B!&- \$Z"\$\$\$S\$#\$\$\$&) \$H<-7?"  
 .....C@B D@5H9 -5K 5GHA 16(, , ZHND9 =Z7C895Z"\$\$\$S) \$#\$\$\$&) \$H<-7?"  
 .....K 9@8: @5B; 9.7<9A =75@7C8J9FGCB 7C5H-5K A @8H@&)) (%Z7@5GG%5"  
 - "GHC F5: 95B8 CD9F5HB; H9A D9F5H F9!)) \*7 HC %&) \*7  
 %&"CF89F-B; 'B: CFA 5HCB.  
 .....D@95G9GD97 =M577CF8-B; HC H<-9: C@C K -B;  
 .....- %& \$\$\$\$, !L  
 D-B 7CI BHfi Z% Z&) Z' +L  
 65G9D5FHBI A 69F

K 5FB-B: 1 H<G8C71 A 98H7CBH5-BGH77<-B-75@85H5%LDCFHC: K <-7< GF9GF 7H98  
 6MH<9%LDCFH5BA B @F5HCB F9 I @5HCBG95F2B G7@CQ F9HC: CF9: B D9F CCBG  
 K #k: C1 HDE-CF1 G: CJ9FBA 98H5DDFCJ5@GDFC<-6H98J C @5HCBGC: H<9%LDCFH  
 @5K G5B8 F9 I @5HCBG5F9G 6-97HHC G9J9F7J @5B8 7F A B5@D9B5@H4G

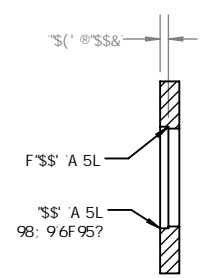
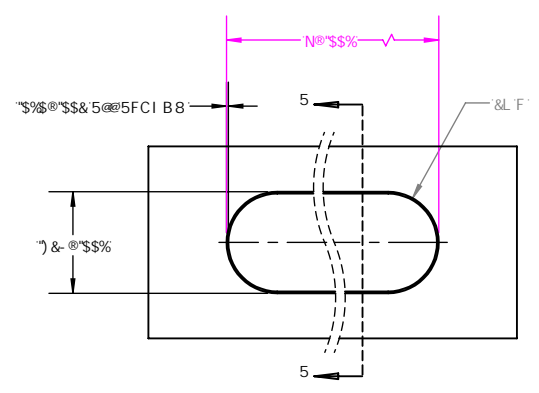
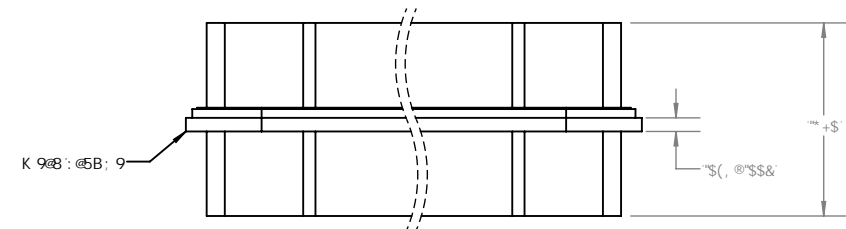
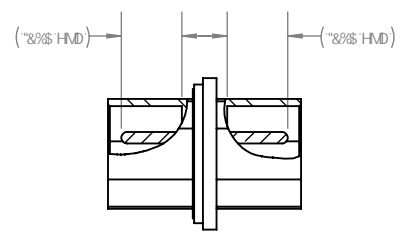
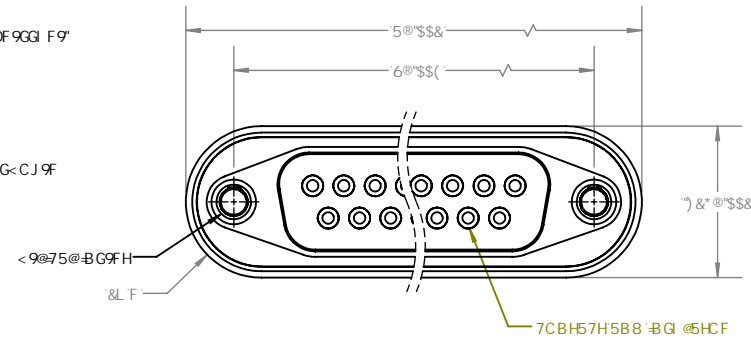

**TABLE 1**

PIN COUNT	Z	A	B
9	1.320	1.317	0.984
15	1.648	1.645	1.312
25	2.188	2.185	1.852
37	2.836	2.833	2.500

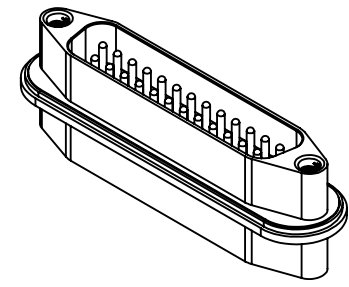

G75@9%.%  
 -%& \$\$\$\$, !&) G<CK B

GI ; ; 9GH98 < C @9 8 9H5 @

**PAE** K K K '<9FA 9H7GC@ HCBG7CA **HEMETICS SOLUTIONS GROUP**

7CBB97HCFZGI 6I8Z7I GHCA

95F1 \*\$\$