

BCHHG

"% GA D-BH9F: 579D9F'A @GH8!' (,"

"&"<9FA 9H7 @5? F5H9 @GGH<5B CF 9E1 5@HC %L %\$ 77#097 <95H%5HA 8±: 9F 9B H5@DF 9GGI F9"

" " 9@97HF =5@F9E1 ± 9A 9BHG

.....A D985B 79.) \$C<A GBCA -B5@

.....: F9E1 9B 7M87 HC &"; <N

" (" A 5H9F -5@C

.....: @5GG: 9FFI @9 ?CJ 5F"

.....K 9@8: @5B: 9CDHCBG G99CF89F-B; 'B: CFA 5HCB"

.....7CBH57H?CJ 5F"

.....BGI @5HCF: +\$+\$; @5GGCF 9E1 ± 5@9BH"

.....: FCI B8 GDF-B; : 69FM@ A 17CDD9F"

)": -B-G<.

.....: FCI B8 GDF-B; Z: @5GG: 9FFI @95B8 7CBH57H B-7?9@D@5H9 -5K 5A GEE!B!&-\$\$\$\$%\$#\$\$\$%) \$H<-7?"

.....: C@8 D@5H9 -5K 5GHA 16(, ZHMD9 -Z7C897Z"\$\$\$%) \$#\$\$\$%) \$H<-7?"

"**"GHCF5: 95B8 CD9F 5HB; 'H9A D9F 5H F9.!) s7 HC Z%) s7"

[+]: FCI B8 GDF-B; : 6GI DD@98 @C095B81 B5H57<98"

" ; "CF89F-B; 'B: CFA 5HCB.

.....D@95G9GD97±M577CF8-B; 'HC H<9: C@CK -B: "

.....: 89B H± MK ±: 65G9D5FHBC Z89F9B HMD9K 9@8: @5B; 9Z5B8 8-A 9B G-CB "5" @9B; H<"

.....9L5A D@9 - 874 \$\$\$\$! G6! 5@! \$, \$

8-A 9B G-CB "5" 1 "LLL
 K 9@8: @5B; 9
 5@ 1 5@ A -BI A (' \$ &
 5@ 1 5@ A -BI A (' \$ +
 GGH1 " \$ (@GH5-B @GGGH99@
 H-1 'H±5B ± A : F589 &
 89F9B HMD9
 G6 1 GA CCH< 6CF 9Z89F9B H-B1 %%)
 @8 1 @A ±H8 89F9B H±89F9B H-B1 %&\$
 : 8 1 : I @89F9B H±89F9B H-B1 %&\$
 65G9D5FHBI A 69F

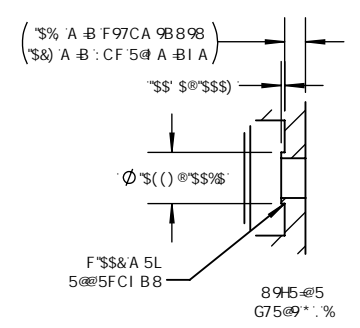
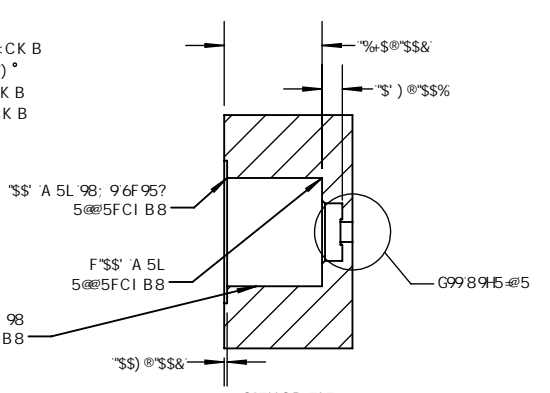
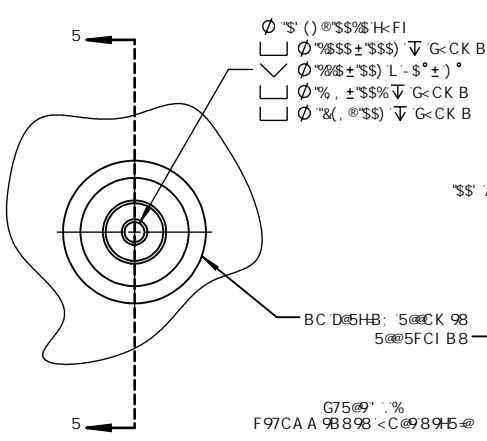
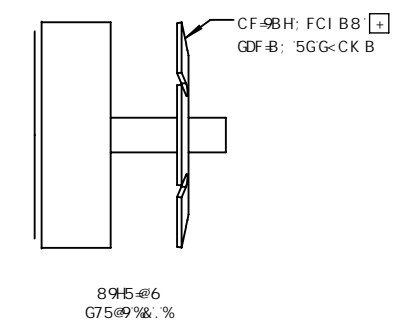
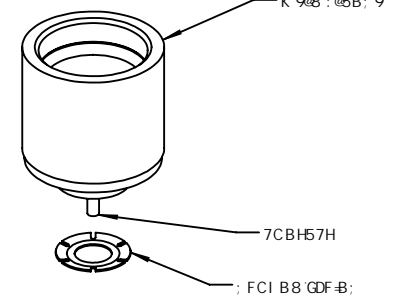
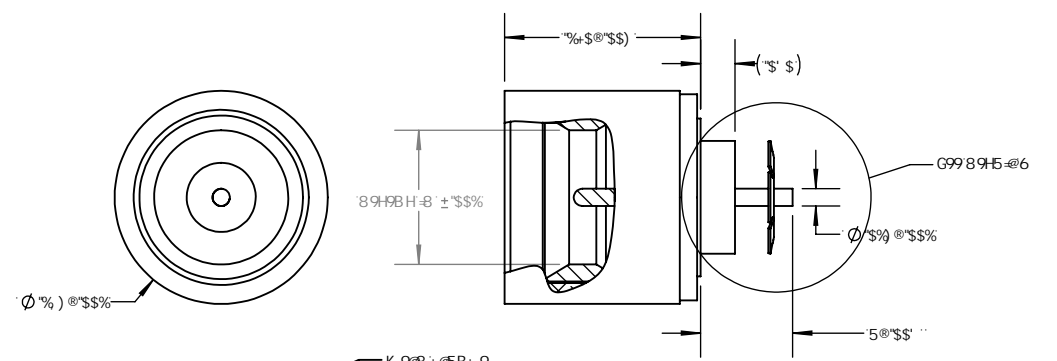

G75@9 % .%

G75@9 * .%
 F97CA A 9B 898 < C @989H5 @

PAVE The Heuric Acoustic

K K K " < 9FA 9H7GC @ HCBG7CA

HERMETIC SOLUTIONS GROUP
 Enabling Technology

HER 7CBB97HCFZGA DZ@5G9F K 9@8

F9I GCB : %

F9@5G9BHR \$& % ! &

G5@G8F5K -B;

75: 97C89 * () +

G75@9. * %

G< 99H % C: %

8C71A 98H

\$! - 874 \$\$\$\$

GI 6>97HHC 7<5B; 9K ±KCI HBCH79

F9I GCB : %	F9@5G9BHR \$& % ! &	G5@G8F5K -B;	75: 97C89 * () +	G75@9. * %	G< 99H % C: %	8C71A 98H	\$! - 874 \$\$\$\$
-------------	---------------------	--------------	-------------------	------------	---------------	-----------	--------------------