

BCH9G
%''-BH9F:579D9F'A-@GH8!'(,
&'<9FA 9H7 @95? F5H9:01 %L %&R!- 77G97 <Y%5HA '8=: 9F9BH5@DF9GG F9'
*''-A D985B79.)\$C<A GBCA -B5@
[]: -B-G<.
.....BG9FH5B8 7CBH57H B]D@5H9D9F '5A GEE!B!&- \$Z"\$\$\$%\$#\$\$\$&\$ H<-??
.....; C@8 D@5H9D9F 5GHA !6(, , ZHMD9 =Z7C895Z"\$\$\$&\$ #\$\$\$%) \$H<-??"
.....; FC1 B8 GDF-B; .B]D@5H9D9F '5A GEE!B!&- \$Z"\$\$\$&\$ #\$\$\$%\$ H<-??
.....; C@8 D@5H9D9F 5GHA !6(, , ZHMD9 =Z7C895Z"\$\$\$&\$ A 5L H<-??"
[] A 5H9F-5@G
.....-BG9FH?CJ5F 5GHA !%)
.....K 9@8 : @5B: 9CDHCBG
.....!5@ A -B1 A ('\$ &
.....!5@ A -B1 A ('\$ +
.....!GH5-B@9GG" \$(@
.....!HH5B+ A ; F589&
.....7CBH57H?CJ5F 5GHA !: %)
.....-BG! @5HCF. +\$+ \$: @5GGCF 9E! =] 5@9BH
.....; FC1 B8 GDF-B; .6Y71 %&#%&'<
**CF89F-B; -B: CFA 5HCB.
.....D@5G9GD97=M6M65G9D5FHBI A 69FZD-B 8-5A 9H9FZ6I G<-B; 'A 5H9F-5@
.....5B8 8-A 9BGC-B "5".
.....9L5A D@9
.....&& \$\$\$\$% ! % ! 5@! &) \$
.....8-A 9BGC-B "5"1 "8) \$'fIA -B-A I A "\$&\$Z A 5L-A I A " \$\$\$&
.....K 9@8 : @5B: 9A 5H9F-5@1 5@(\$ (+ fCDHCBG 5@(\$ (+ "5@-Z5@\$' &
.....5@&'Z' \$(@GGH"GGH" 5B8 H] f&"H&'L
.....D-B 8-5A 9H9F1 "\$%) fCDHCBG "\$%&Z"\$%) Z5B8 "\$&\$&
.....65G9D5FHBI A 69F
+"; FC1 B8 GDF-B; 'G<5@69G<-DD98 @CCG9'
.....

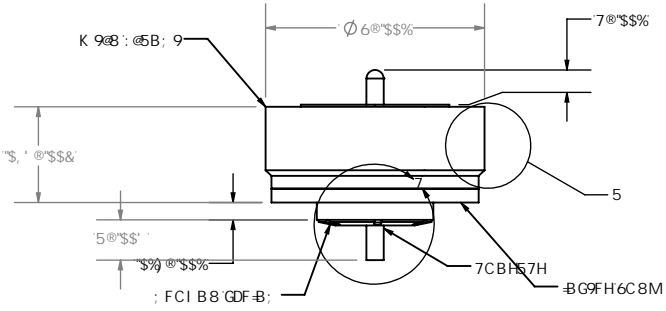

K 5FB-B: 1 H<-G8C7I A 9BH7CBH5-BGH97<-B-75@85H5Z9LDCFHC: K <-7<-GF9GF 7H98
6MH<-99LDCFH58A -B-GF5HCB F9 I @5HCBG195F8-G7@CG F9HC: CF9: B DF9GCBG
K H<-CI HDF<-CF1 G': CJ9FBA 9BH5DDFCJ5@GDFC<-6H98"J<-@5HCBG: H<-99LDCFH
@K G5B8 F9 I @5HCBG5F9G 6-97HHC G9]9F97J @5B8 7F A -B5@D9B5H49G

H56@9%		
- && \$\$\$\$% LLLLLLLLL	8-A 9BGC-B 6	8-A 9BGC-B 7
- && \$\$\$\$% @ LLLLLLLLL	%-\$	"\$('
- && \$\$\$\$% @ LLLLLLLLL	% \$	"\$*\$
- && \$\$\$\$% & \$ LLLLLLLLL	"&&&	"\$*\$

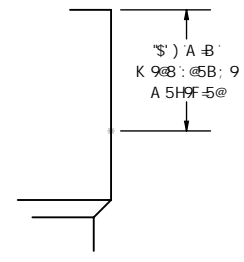
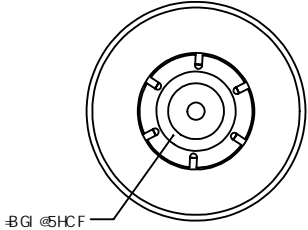

8 9H5 @5
G75@9% . %

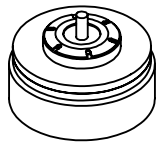

G75@9(: %

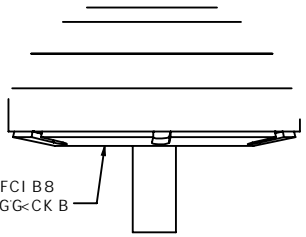

8 9H5 @7
G75@9% . %

PA-E K K K '<9FA 9H7GC@ HCBG7CA **HEOMETRICSOLUTIONSGROUP**

7CBB97HCFZF: : @5B: 9A CI BHZ@5G9F K 9@8

J9FGCB 5"\$ F995G9B5H9 &&(!& G5@G8F5K -B; 75: 97C89 *() +* G75@9. *% G<99H %C: & BC71A 9BH \$! - && \$\$\$\$%

B: CFA 5HCB < 9F9B 'GG 6-97HHC H-985H5 F< <HG
5B8 9LDCFH7CBHFC@09 9B8GCB G< 99H1%

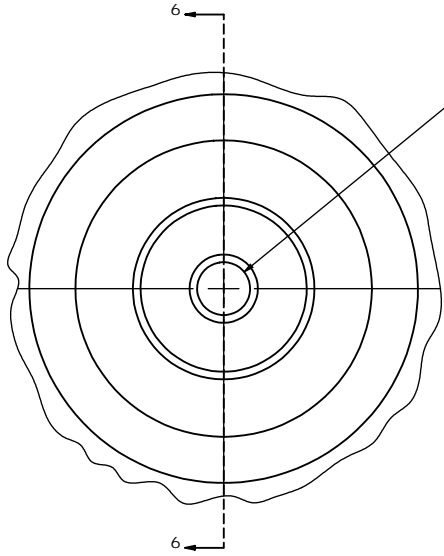

- Ø 8@'\$\$\$% H<FI
- Ø: ±'\$\$\$) ∇ G<CK B
- ∨ Ø: ±'\$\$\$) L- \$ ±)
- Ø< ±'\$\$\$% ∇ G<CK B
- Ø> ±'\$\$\$) ∇ G<CK B

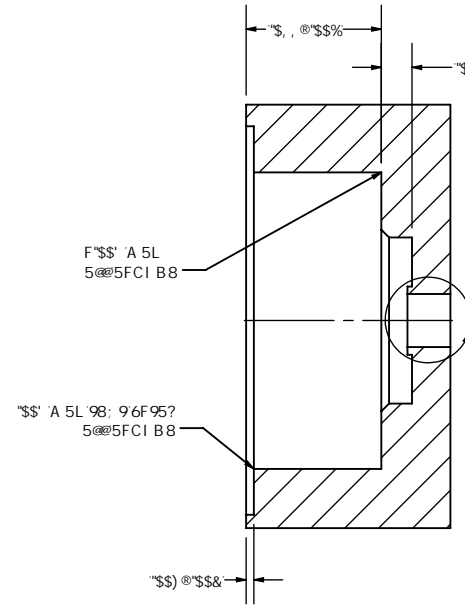

G97HCB '616

G75@9, '1%
< C @ 9 89H5 = @

H56@9 &						
- && \$\$\$% LLLLLLLL	8-A 9B G-CB 8	8-A 9B G-CB '9	8-A 9B G-CB :	8-A 9B G-CB ;	8-A 9B G-CB <	8-A 9B G-CB >
- && \$\$\$% %& LLLLLLLL	"\$&+"	"\$.)	"\$, +\$	"\$- +	"%&'	"&'
- && \$\$\$% %! LLLLLLLL	"\$ ()	"\$ (()	"%& &	"%&	"% '	"&)"
- && \$\$\$% &\$! LLLLLLLL	"\$ (* \$	"\$) *)	"% \$'	"%(\$	"&&)"	"&.)

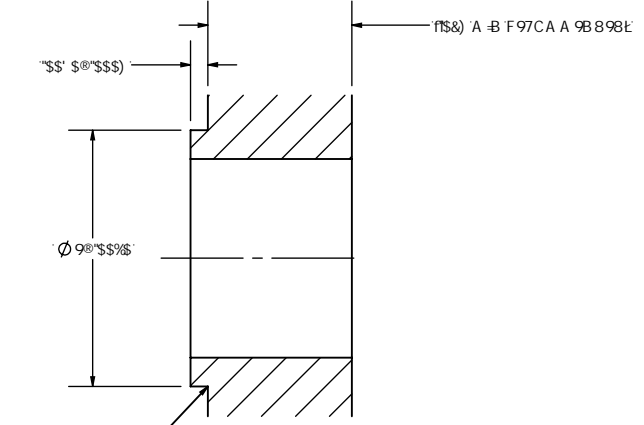

89H5@8
G75@9' \$.'%

75: 97C8& (0)*	F0: 5'\$	8C71 A 9BH	\$! - && \$\$\$%
8F5K -B: GN9.5	G75@9, %%	G< 99H &C: &	