



### Features and Benefits

- HCMOS output signal
- Operating temperature -40°C to +85°C
- Less than +/- 0.5 ppb per day aging
- Less than +/- 50 ppb per year aging
- SC Cut Crystal

### Typical Applications

- SDH/SONET, Telecommunication base station
- Test and measurement equipment
- Synthesizer, Digital switch, Reference Timing Circuit

### Mechanical Drawing & Pin Connections

Drawing No: MD160045-1

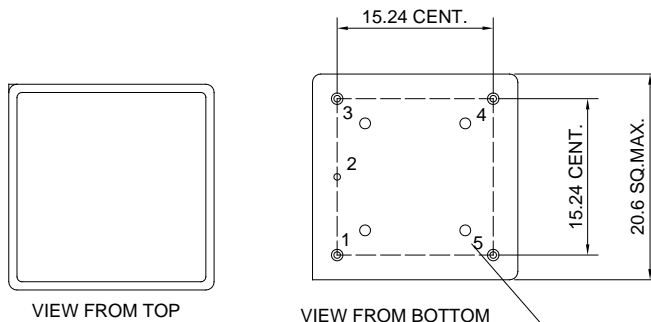

NUMBERS FOR REFERENCE ONLY  
(NOT STAMPED ON UNIT)

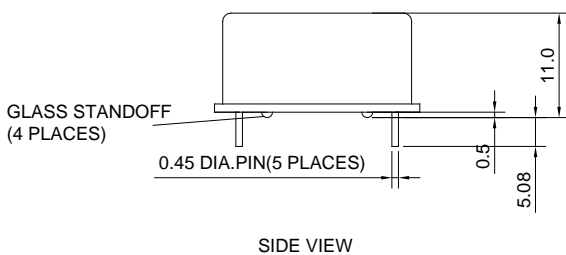

#### PIN CONNECTION 1

Pin	Signal
1	CONTROL VOLTAGE
2	REFERENCE VOLTAGE
3	GND
4	R.F. OUTPUT
5	VCC

#### PIN CONNECTION 2

Pin	Signal
1	VCC
2	R.F. OUTPUT
3	GND
4	CONTROL VOLTAGE
5	REFERENCE VOLTAGE

Unit: mm  
1mm=0.039inch



Specifications

OCXO Specification	Sym	Condition	Value			Unit	Note
			Min.	Typ.	Max.		
Frequency Range	F <sub>0</sub>			10.000000		MHz	
<b>RF Output</b>							
Output Waveform			Rectangular				
Level				HCMOS			
Output Level"1"			+3.5			V	
Output Level"0"					+0.5	V	
Load				15		pF	
Duty Cycle		@+2.0V	45	50	55	%	
Spurious					-60	dBc	
<b>Power Supply</b>							
Voltage	V <sub>cc</sub>		4.75	5	5.25	V	3.3V input voltage is available.
Current		Warm-up			500	mA	
Power		Steady State			1.0	W	@+25°C
<b>Reference Voltage</b>							
Reference Voltage			3.8	4.0	4.2	V	
Load			9			Kohm	
<b>Frequency Control*</b>							
Tuning Range		VCO @0			-0.5	ppm	
		VCO @4V	+0.5			ppm	
Control Voltage	V <sub>c</sub>		0	2	4	V	
Slope				Positive			
Input Impedance			100			Kohm	
<b>Frequency Stability</b>							
Vs. Ambient		-30°C to +70°C			+/-10	ppb	Ref. to +25°C, Refer to Freq. Stability Vs Temp. Range table.
Vs. Supply Voltage Change		+/-5% change			+/-0.5	ppb	
Warm-up		In 3 minutes @+25°C			+/-50	ppb	Ref. to 1hour
Aging	Per Day	After 30 Days			+/-0.5	ppb	
	Per Year				+/-50	ppb	
	10 Years				+/-0.3	ppm	
<b>Phase Noise</b>							
Phase Noise		@10Hz			-115	dBc/Hz	
		@100Hz			-135	dBc/Hz	
		@1KHz			-145	dBc/Hz	
		@10KHz			-150	dBc/Hz	

Table 1:

Temperature Range vs. Stability Availability			
Temperature range (°C)	±5ppb	±10ppb	±20ppb
-30 to +70	Available	Available	Available
-40 to +85	Available	Available	Available