

## XO7500L-G2

40 to 200 MHz LVDS Lowest Jitter Clock

### Features

- 40 to 200 MHz
- 7.0 mm x 5.0 mm x 1.8 mm ceramic SMD
- Compact and lightweight
- Differential LVDS Outputs
- 2.5 or 3.3 v supply
- 0.3 ps integrated phase jitter typ.

### Picture of Part



### Description

The XO7500L-G2 features the use of high frequency fundamental crystals in non-PLL based circuitry to achieve the lowest possible jitter and phase noise performance. LVDS outputs exceed the requirements for SONET, XDSL, and other telecommunication standards.

### Physical Dimensions & Pin Connections

Unit:mm

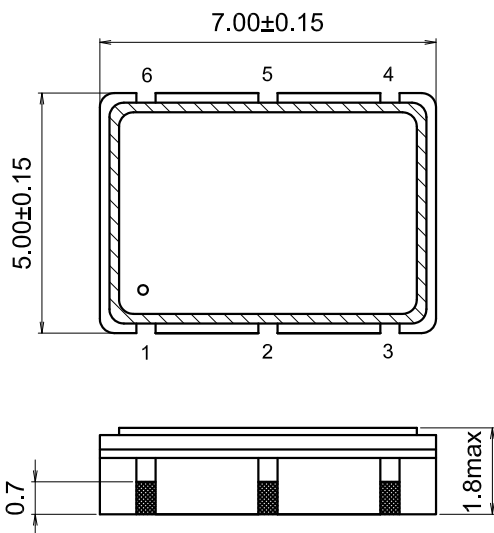

Pad1	Tri-state	Pad4	LVDS Output
Pad2	No Connection	Pad5	LVDS Output
Pad3	Ground	Pad6	Supply Voltage

Rounded pad is pad No.1

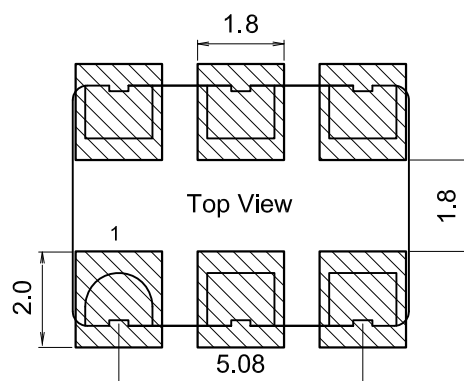
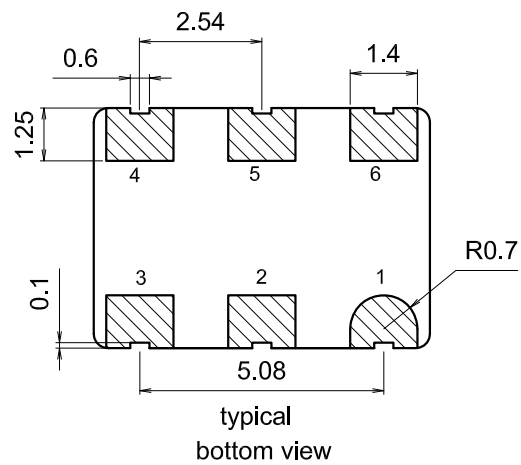

# XO7500L-G2

40 to 200 MHz LVDS Lowest Jitter Clock

## Specification

LVDS XO (Next Generation)		Sym.	Condition	Value			Unit	Note
				Min.	Typ.	Max.		
<b>Frequency Range</b>		$f_0$		40		200	MHz	
LVDS Outputs	Output High Voltage				1.430	1.600	V	
	Output Low Voltage			0.900	1.100		V	
	Output Differential		Voltage	250	350	450	MV	millivolts
	Duty Cycle		Measured at 50% of waveform	45	50	55	%	
	Rise / Fall Time			0.20	0.40		ns	**measured at 20 to 80% of the waveform
			Start up Time		3.0	10	ms	
<b>Power supply</b>								
Voltage		Vcc		3.150	3.300	3.450	V	2.5V +/- 5% available
Current consumption		Icc	Current Drain is a function of frequency		16.0	27.0	mA	
<b>Pad 1 Enable Disable Function</b>								
			Voltage applied to pad 1	70% Vcc			volts	In the disabled mode, both outputs are enabled when Pad 1 is taken
								Above 70% of Vcc ref to
								Ground ( threshold )
<b>Pad 1 Enable Disable Function</b>								
			Voltage applied to pad 1			30% Vcc	volts	Both outputs are disabled when
			Oscillator circuit is always on.					Pad 1 is taken below 30% Vcc.
			Only buffer circuit is turned OFF					
Typical Phase Noise as a Function of Operating Frequency			Freq. OFFSET	1KHz	10KHz	100KHz		
			125 MHz	-120	-136	-142		
			Frequency Domain Phase Jitter		0.300		PS RMS	Integrated from 12KHz to 20MHz Max.
<b>Environmental, mechanical conditions.</b>								
Operating temperature range		<b>-40°C to +85°C maximum range available that is standard</b>						
Storage temperature range		<b>-55°C to 125°C</b>						
Humidity		85% RH ; 85C ; 48 hours of exposure						
Vibration		Mil-Std 202F , Method 204, 35G's, 50 to 2000 Hz						
Shock		Mil-Std 202F, Method 213B, test condition E, 1000 GG half sine wave						
Reflow		<b>+260°C for 10 seconds</b>						



## Ordering Information

XO7500L-G2-XXX.XXXXXX-W-Y

1. Field "XXX.XXXXXX" is the Output Frequency to six decimals in MHz
2. Field "W" is Operating Temperature Range and Freq. Stability :
  - a. "0" for -10°C to +70°C and +/- 25 ppm
  - b. "1" for -10°C to +70°C and +/- 50 ppm
  - c. "2" for -10°C to +70°C and +/- 100 ppm
  - d. "3" for -40°C to +85°C and +/- 25 ppm
  - e. "4" for -40°C to +85°C and +/- 50 ppm
  - f. "5" for -40°C to +85°C and +/- 100 ppm
3. Field "Y" is Power Supply Option
  - a. "0" for 2.5 V +/- 5%
  - b. "1" for 3.3 V +/- 5%

## Part Number Example

XO7500L-G2-125.000000-5-0

125.000000 MHz Operating Frequency

Operating Temperature of -40°C to +85°C

+/- 100 ppm Overall Frequency Stability

2.5 V +/- 5% supply voltage

Typical Phase Noise Plot

