

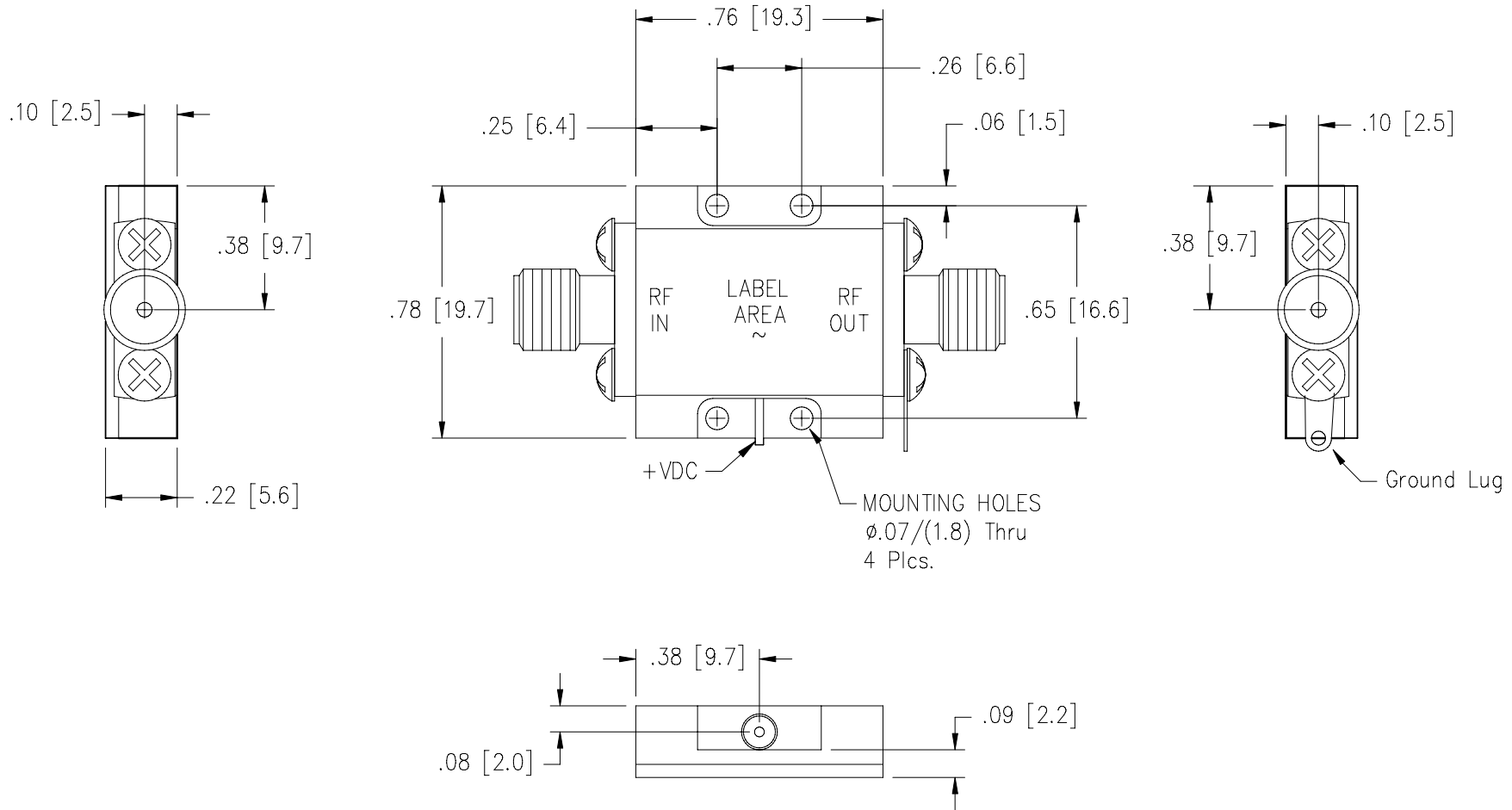

MICROWAVE SOLUTIONS INC.
 PROPRIETARY AND PRIVATE
 THE INFORMATION CONTAINED IN THIS
 DOCUMENT OR ITEM IS THE
 PROPERTY OF MICROWAVE SOLUTIONS
 INC. (MSI) AND SHALL BE KEPT IN
 STRICT CONFIDENCE EXCEPT WITH
 WRITTEN PERMISSION OF MSI.

REVISIONS			
REV.	DESCRIPTION	DATE	APPRVD
E	REVISE PER ECO 2530 JT	020104	
F	REVISE PER ECO 2797 SY	6/7/05	



NOTES:

1. Removable "SMA" connectors.
2. RF pin diameter = .02" x .07" in length.
3. Input voltage pin is $\phi.03$ ".
4. Dimensions are in Inches/[mm.].
5. Ground Lug can be placed on input if requested

THIS DWG IS PRELIMINARY UNLESS STAMPED RELEASED	NOTE: THIS DWG INCORPORATES THIRD ANGLE PROJECTION	UNLESS OTHERWISE SPECIFIED DIMENSIONS ARE IN INCHES	DRWN: Judy Thomas	020104	 microwave solutions inc. NATIONAL CITY CALIFORNIA
		TOLERANCES ARE: FRACTIONS DECIMALS ANGLES $\pm 1/64$ $XX \pm .010$ $\pm 1/2^\circ$ $XXX \pm .005$	CHECKED		
		UNLESS OTHERWISE SPECIFIED \checkmark ALL OVER	ENG:		OUTLINE DRAWING, X/K-BAND, DROP-IN, AMPLIFIER
		MATERIAL:	PROD:		
		FINISH:	QA:		SIZE A FSCM NO. 65151 DWG NO. OL-001621-2 REV. F
		DO NOT SCALE DRAWING	APPROVALS:	CAD FILE: OL1621-2_F	WEIGHT: 11.5 G SCALE: 2X SHEET 1 OF 1