

DESCRIPTION

PMI MODEL SAA-218-6-093-013542 OPT. HERM IS A SWITCHABLE RF ATTENUATOR FOR SIX SIGNAL PATHS OPERATING FROM 2 TO 18 GHz. DESIGNED TO BE SWITCHED BETWEEN A LOW LOSS STATE (2 dB LOSS TYPICAL) AND A HIGH LOSS STATE (20 dB LOSS TYPICAL). THE SETTINGS WILL BE SELECTED BY SIX DIGITAL CONTROL BITS.

SPECIFICATIONS

- FREQUENCY RANGE: _____ 2 TO 18 GHz
- LOGIC HIGH VOLTAGE, VH: _____ 2.0 V MINIMUM, 3.5 V MAXIMUM
- LOGIC LOW VOLTAGE, VL: _____ 0 V MINIMUM, 0.8 V MAXIMUM
- CURRENT AT VH: _____ 0 mA MINIMUM, 24 mA MAXIMUM
- CURRENT AT VL: _____ 0 mA MINIMUM, 24 mA MAXIMUM
- LOAD CAPACITANCE: _____ 0 pF MINIMUM, 35 pF MAXIMUM
- RISE TIME: _____ 1.0 ns MINIMUM, 2.0 ns TYPICAL, 10.0 ns MAXIMUM
- FALL TIME: _____ 1.0 ns MINIMUM, 2.0 ns TYPICAL, 10.0 ns MAXIMUM
- RESPONSE TIME: _____ 100 ns MAXIMUM (50% VOLTAGE OF INPUT LOGIC SIGNAL TO 1 dB OF FINAL VALUE OF RF ATTENUATION)
- REPETITION RATE: _____ SUPPORT SWITCHING FROM DC TO 500 kHz
- INSERTION LOSS (LOW LOSS PATH) 1dB Min. 4dB Max.
- INSERTION LOSS (HIGH LOSS PATH) 18dB Min. 22dB Max. ***
- TOLERANCE AND FLATNESS: _____ LOW LOSS: +1 dB, -2 dB (IL OF 1 dB TO 4 dB)
HIGH LOSS: +2 dB, -2 dB (IL OF 18 dB TO 22 dB) ***
- VSWR: _____ 2.0:1 MAXIMUM
- OUTPUT 1 dB COMPRESSION: _____ 18 dBm
- ISOLATION: _____ 50 dB MINIMUM, BETWEEN ANY OF THE SIX OUTPUTS WITH ANY SWITCH SETTING
- STABILITY: _____ < -70 dBm SPURIOUS OUTPUT SIGNAL*
- VIDEO SPIKE LEAKAGE: _____ < 500 mV PEAK TO PEAK (MEASURED WITH A MINIMUM BANDWIDTH OF 200 MHz)
- SPECTRAL ACTIVITY: _____ -70 dBm MAXIMUM @ 500 kHz SWITCHING RATE
- DC VOLTAGE: _____ -5 ± 0.1 VDC @ 0.30 A MAXIMUM
+5 ± 0.1 VDC @ 0.30 A MAXIMUM
- AC RIPPLE: _____ 120 mV PEAK TO PEAK MAXIMUM**
- CONNECTORS
 - INPUT - OUTPUT: _____ SMA (F) REMOVABLE
 - CONTROL & POWER: _____ 9 PIN MICRO D PLUG (M83513-03A03C)
- SIZE: _____ 1.959" (MAX) X 4.000" (MAX) X 0.810" (MAX)
- WEIGHT: _____ 1.0 LBS MAXIMUM
- FINISH: _____ PLATE & WIRE BAR - CHEMICAL FILM :
YELLOW COLOR CLASS 3 PER MIL-C-5541

ATTENUATORS - GOLD PLATED AND HERMETICALLY SEALED

- * SHOULD BE UNCONDITIONALLY STABLE PER THE FOLLOWING CONDITIONS: A, B, C
 A. WITH ANY INPUT OR OUTPUT PORT TERMINATED IN ANY PASSIVE SOURCE OR LOAD IMPEDANCE
 B. WITH INPUT POWER LEVELS RANGING FROM NO INPUT TO THE MAXIMUM THAT IS SPECIFIED ON TABLE 1
 C. WITH ANY OPERATING TEMPERATURE SPECIFIED IN TABLE 1

** AC RIPPLE FREQUENCY IS 600 kHz TYPICAL

*** DO NOT NORMALIZE INSERTION LOSS (LOW LOSS PATH) WHEN MEASURING HIGH LOSS PATH

NOTE: SPECIFICATIONS WILL VARY OVER OPERATING TEMPERATURE
 NOTE: THE ABOVE SPECIFICATIONS ARE SUBJECT TO CHANGE OR REVISION

ENVIRONMENTAL RATINGS:

◦ TABLE 1: ABSOLUTE MAXIMUM RATINGS

PARAMETER	ZONE	SPECIFICATION
CONTINUOUS OPERATING TEMPERATURE	B	-40 °C TO 71.1 °C - CONTINUOUS N/A - MTBF
	C	-40 °C TO 71.1 °C - CONTINUOUS N/A - MTBF
TRANSIENT TEMPERATURE	B	-53.9 °C TO 48.9 °C
	C	TBD
STORAGE TEMPERATURE	ALL	-53.9 °C TO 95 °C
SURROUNDING AIR PRESSURE UNPRESSURIZED AREAS, EQUIPMENT BAYS	ALL	0.44 PSIA TO 15.5 PSIA AT 0.6 PSI/SEC
NON-GUNFIRING VIBRATION ENVIRONMENT	ALL	FIGURE 1, VIBRATION VALUES (SEE PAGE 2)
GUNFIRING VIBRATION ENVIRONMENT	ALL	FIGURE 2, GUNFIRING VIBRATION VALUES (SEE PAGE 2)
CONTINUOUS RF INPUT POWER (1)	N/A	24 dBm (MAXIMUM)
+5 VOLT POWER SUPPLY	N/A	+6 V (MAXIMUM)
-5 VOLT POWER SUPPLY	N/A	+6 V (MINIMUM)

NOTE 1: IN THE FREQUENCY BAND OF 2 TO 18 GHz

◦ TABLE 3: RF INPUT AND OUTPUT CONNECTORS

CONNECTOR	SIGNAL NAME	SPECIFICATION
J2	ATTEN LF A INPUT	OUTPUT CONTROL
J8	ATTEN LF A OUTPUT	LEFT FORWARD TRANSMITTER A
J3	ATTEN LF B INPUT	OUTPUT CONTROL
J9	ATTEN LF B OUTPUT	LEFT FORWARD TRANSMITTER B
J4	ATTEN RF A INPUT	OUTPUT CONTROL
J10	ATTEN RF A OUTPUT	RIGHT FORWARD TRANSMITTER A
J5	ATTEN RF B INPUT	OUTPUT CONTROL
J11	ATTEN RF B OUTPUT	RIGHT FORWARD TRANSMITTER B
J6	ATTEN AFT A INPUT	OUTPUT CONTROL
J12	ATTEN AFT A OUTPUT	AFT TRANSMITTER A
J7	ATTEN AFT B INPUT	OUTPUT CONTROL
J13	ATTEN AFT B OUTPUT	AFT TRANSMITTER B

REVISIONS				
ZONE	REV.	DESCRIPTION	DATE	APPROVED
	1	ORIGINAL RELEASE	03/25/15	
	A1	ECN # 16-0064	04-22-16	
	B1	ECN # 18-0196	09/20/18	
	C1	ECN # 18-0216	10/10/18	

◦ TABLE 2: P1 CONNECTOR

PIN NO.	SIGNAL NAME	SPECIFICATION
1	ATTEN LF A	ATTENUATION CONTROL BIT LF A
2	ATTEN LF B	ATTENUATION CONTROL BIT LF B
3	ATTEN RF A	ATTENUATION CONTROL BIT RF A
4	ATTEN RF B	ATTENUATION CONTROL BIT RF B
5	ATTEN AFT A	ATTENUATION CONTROL BIT AFT A
6	ATTEN AFT B	ATTENUATION CONTROL BIT AFT B
7	-5 VDC	DC POWER
8	GROUND	GROUND
9	+5 VDC	DC POWER

PMI CONFIDENTIAL AND PROPRIETARY

PLANAR MONOLITHICS INDUSTRIES, INC.

7311-F GROVE ROAD
 FREDERICK, MARYLAND 21704 USA
 TEL: 301-662-5019 FAX: 301-662-1731
 WEBSITE: www.pmi-rf.com
 E-MAIL: sales@pmi-rf.com
 ISO 9001 CERTIFIED



APPROVALS		DATE	TITLE		
DRAWN VR		03/25/15	PRODUCT FEATURE SAA-218-6-093-013542 OPT. HERM		
CHECKED			SIZE B	FSCM NO. 05XQ0	DWG NO. 27013482
ISSUED					REV. C1
SCALE N:S			SHEET 1 OF 3		

ALL DIMENSIONS ARE IN INCHES
 TOLERANCES:
 X.XX ±0.020
 X.XXX ±0.010

DESCRIPTION

PMI MODEL SAA-218-6-093-013542 OPT. HERM IS A SWITCHABLE RF ATTENUATOR FOR SIX SIGNAL PATHS OPERATING FROM 2 TO 18 GHz. DESIGNED TO BE SWITCHED BETWEEN A LOW LOSS STATE (2 dB LOSS TYPICAL) AND A HIGH LOSS STATE (20 dB LOSS TYPICAL). THE SETTINGS WILL BE SELECTED BY SIX DIGITAL CONTROL BITS.

• NON-GUNFIRING VIBRATION ENVIRONMENT

Figure 1: Minimal Integrity Test – General
MIL-STD-810, 514.4-39, Modified

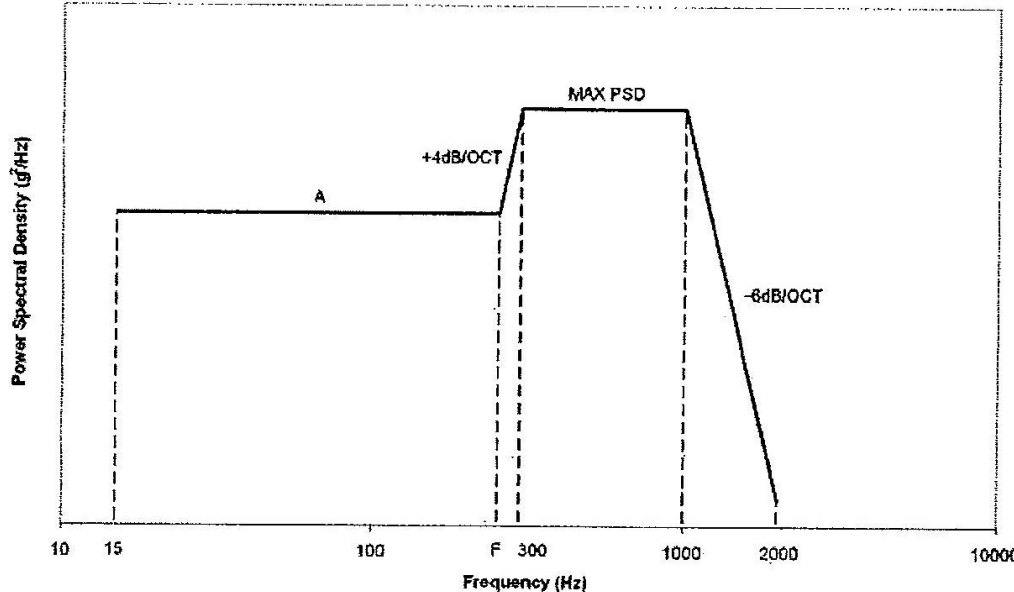

Vibration Values

Zone	Performance			Endurance		
	A	MAX PSD	F (REF)	A	MAX PSD	F (REF)
A	0.020	0.025	253.8	0.020	0.033	206.1
B	0.020	0.040	178.4	0.020	0.053	144.4
C	0.040	0.070	197.2	0.040	0.093	159.3
E	0.040	0.280	69.7	0.040	0.370	56.6
F	0.040	0.140	117.2	0.040	0.186	94.7

• GUNFIRING VIBRATION ENVIRONMENT

Figure 2: Gunfiring Vibration Environment

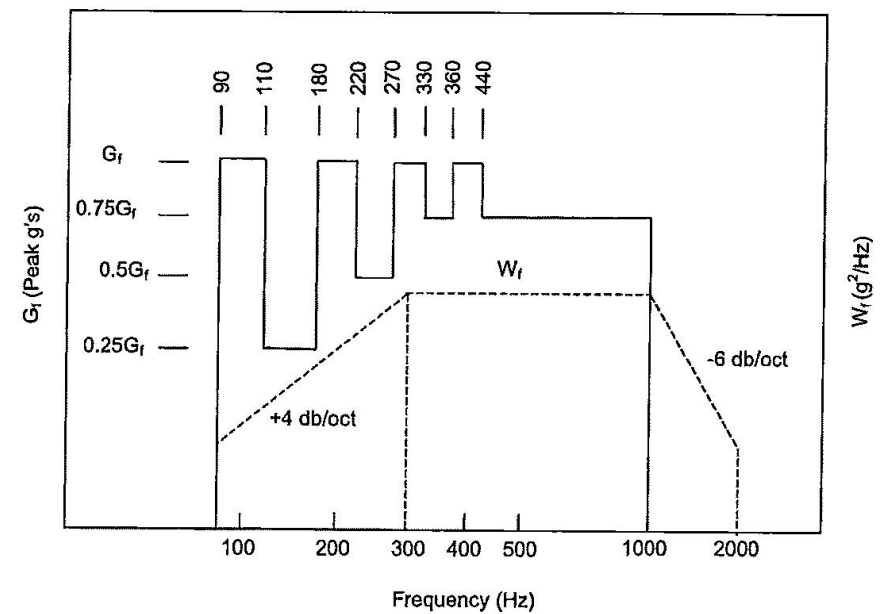

Gunfiring Vibration Values

	Gf	Wf PSD
A	2.7	0.012
B	8.4	0.036
C	3.3	0.014
E	SEE 3.2.12	
F	N/A	N/A

PMI CONFIDENTIAL AND PROPRIETARY

PLANAR MONOLITHICS INDUSTRIES, INC.

7311-F GROVE ROAD
FREDERICK, MARYLAND 21704 USA
TEL: 301-662-5019 FAX: 301-662-1731
WEBSITE: www.pmi-rf.com
E-MAIL: sales@pmi-rf.com
ISO 9001 CERTIFIED



NOTE: SPECIFICATIONS WILL VARY OVER OPERATING TEMPERATURE
NOTE: THE ABOVE SPECIFICATIONS ARE SUBJECT TO CHANGE OR REVISION

ALL DIMENSIONS ARE IN INCHES
TOLERANCES:
X.XX ±0.020
X.XXX ±0.010

APPROVALS		DATE	TITLE		
DRAWN		03/25/15	PRODUCT FEATURE		
CHECKED			SAA-218-6-093-013542 OPT. HERM		
ISSUED			SIZE	FSCM NO.	DWG NO.
			B	05XQ0	27013482
			SCALE	N:S	SHEET 2 OF 3
			REV.	C1	

DESCRIPTION

PMI MODEL SAA-218-6-093-013542 OPT. HERM IS A SWITCHABLE RF ATTENUATOR FOR SIX SIGNAL PATHS OPERATING FROM 2 TO 18 GHz. DESIGNED TO BE SWITCHED BETWEEN A LOW LOSS STATE (2 dB LOSS TYPICAL) AND A HIGH LOSS STATE (20 dB LOSS TYPICAL). THE SETTINGS WILL BE SELECTED BY SIX DIGITAL CONTROL BITS.

MECHANICAL OUTLINE

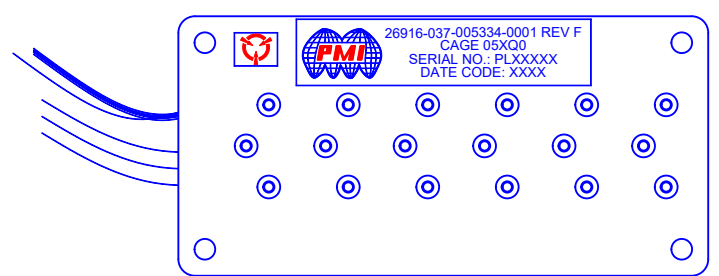
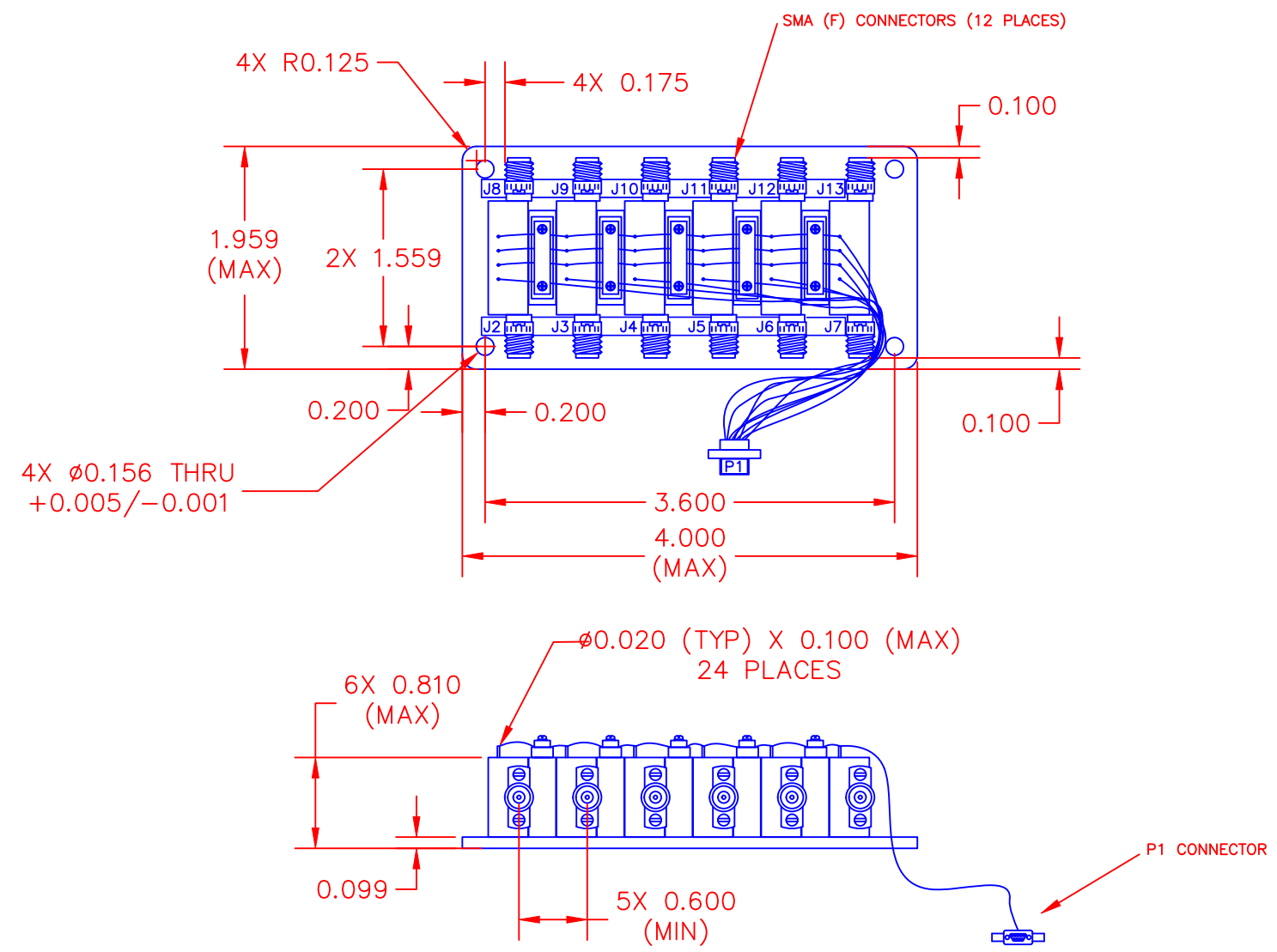

BLOCK DIAGRAM

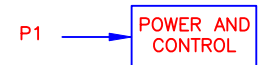
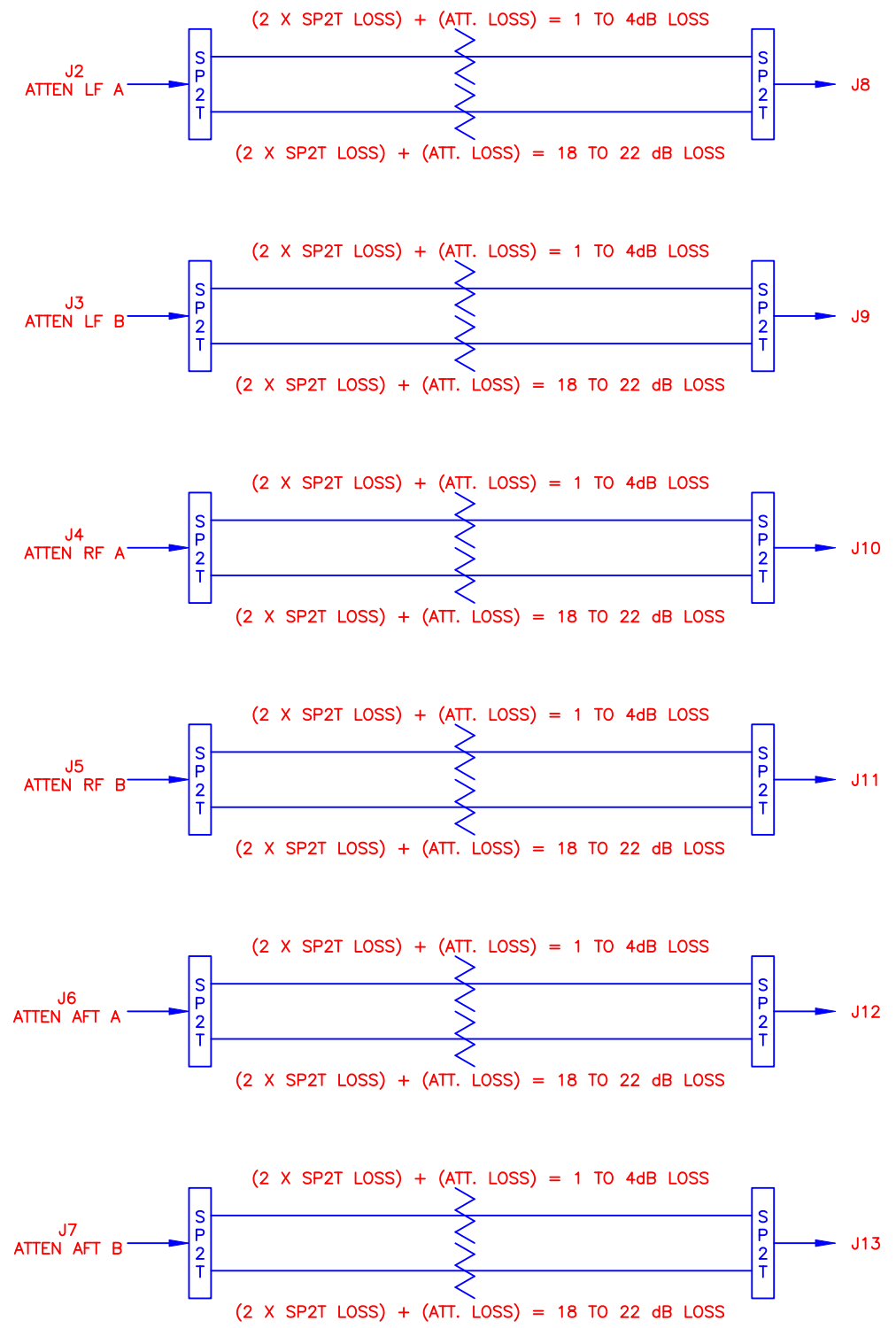

PMI CONFIDENTIAL AND PROPRIETARY

PLANAR MONOLITHICS INDUSTRIES, INC.
 7311-F GROVE ROAD
 FREDERICK, MARYLAND 21704 USA
 TEL: 301-662-5019 FAX: 301-662-1731
 WEBSITE: www.pmi-rf.com
 E-MAIL: sales@pmi-rf.com
 ISO 9001 CERTIFIED



APPROVALS		DATE	TITLE		
DRAWN VR		03/25/15	PRODUCT FEATURE		
CHECKED			SAA-218-6-093-013542 OPT. HERM		
ISSUED			SIZE B	FSCM NO. 05XQ0	DWG NO. 27013482
			SCALE N:S	SHEET 3 OF 3	REV. C1

NOTE: SPECIFICATIONS WILL VARY OVER OPERATING TEMPERATURE
 NOTE: THE ABOVE SPECIFICATIONS ARE SUBJECT TO CHANGE OR REVISION

ALL DIMENSIONS ARE IN INCHES
 TOLERANCES:
 X.XX ±0.020
 X.XXX ±0.010