

DESCRIPTION:

PMI MODEL NUMBER BPF-2D7G3D55G-850M-SFF IS A BANDPASS FILTER WITH A 1 dB BANDWIDTH OF 850 MHz MINIMUM COVERING 2700 TO 3550 MHz.

ZONE	REV.	DESCRIPTION	DATE	APPROVED
	A1	ORIGINAL RELEASE	1/3/2022	

SPECIFICATIONS:

- 1 dB PASSBAND FREQUENCY RANGE:..... 2.7 GHz TO 3.55 GHz MIN
- PASSBAND BANDWIDTH:..... 850 MHz MIN
- PASSBAND VSWR:..... 1.5:1 TYP, 2.0:1 MAX
- PASSBAND INSERTION LOSS:..... 3.5 dB MAXIMUM
- REJECTION:
 - 0.1 TO 2.488 GHz:..... -60 dBc MINIMUM
 - 3.763 TO 6.0 GHz:..... -60 dBc MINIMUM
- CONNECTORS:..... SMA FEMALE CONNECTORS (FIELD REMOVABLE)
- FINISH:..... SILVER PLATED

ENVIRONMENTAL RATINGS:

- TEMPERATURE:..... -40°C TO +85°C (OPERATING)
..... -65°C TO +125°C (STORAGE)

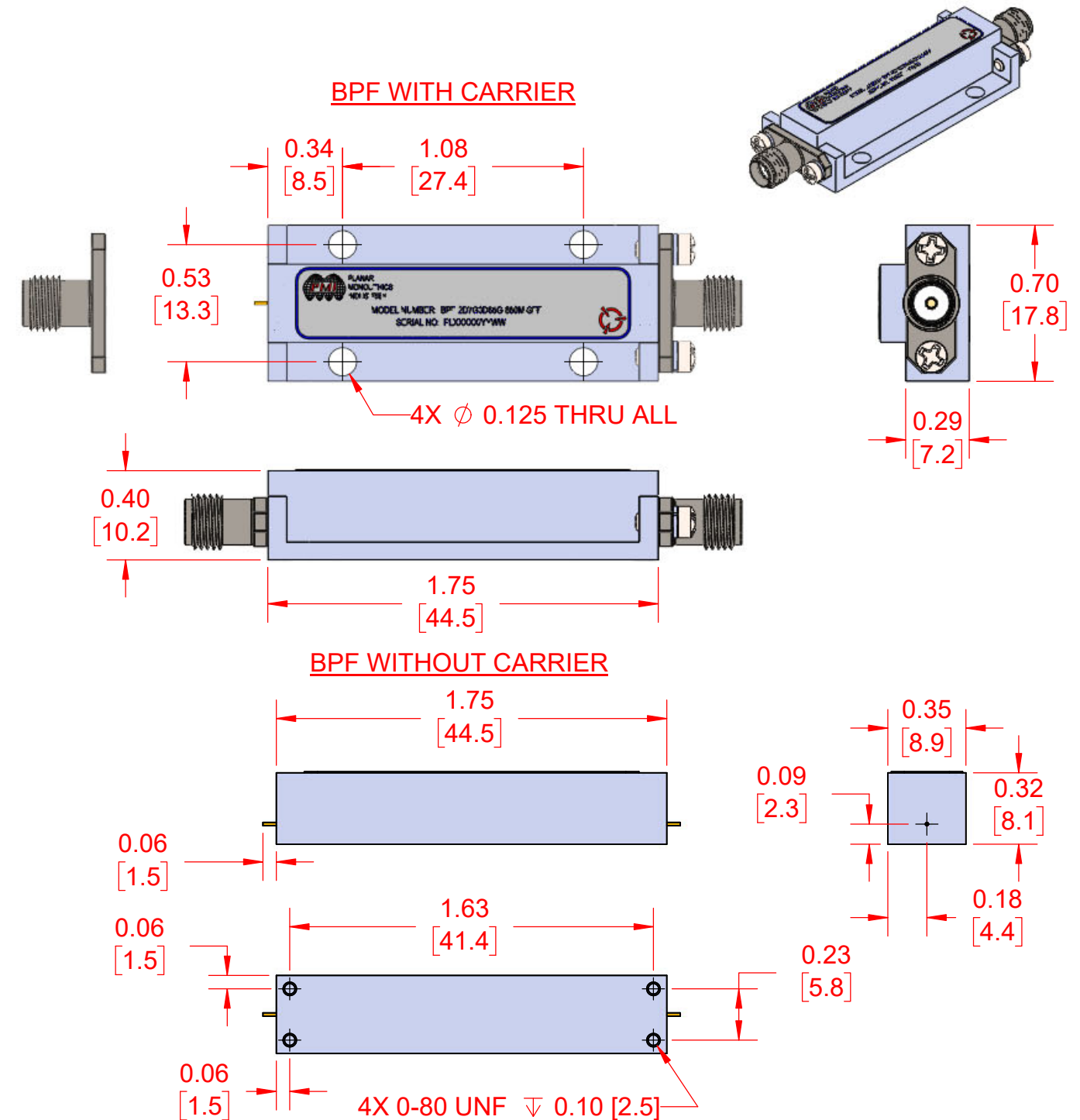

PMI CONFIDENTIAL AND PROPRIETARY

APPROVALS DRAWN R. SIRK REDRAWN ISSUED		DATE		TITLE 2700-3550 MHz BANDPASS FILTER BPF-2D7G3D55G-850M-SFF	
		1/3/2022			
UNLESS OTHERWISE SPECIFIED DIMENSIONS ARE IN INCHES TOLERANCES ARE: FRACTIONS DECIMALS ANGLES ± .XX ± 0.02 ± .XXX ± 0.01		SIZE	FSCM NO.	DWG NO.	REV.
		B	05XQ0	27043660	A1
SCALE 3:2				SHEET 1 OF 1	

PLANAR MONOLITHICS INDUSTRIES, INC.
 7311-F GROVE ROAD
 FREDERICK, MARYLAND 21704 USA
 TEL: (301)-862-5019, FAX: (301)-662-1731
 WEB: www.pmi-rf.com, EMAIL: sales@pmi-rf.com
 ISO 9001 CERTIFIED