

DESCRIPTION:

PMI MODEL EWDM-8G18G-65-70MV-2 IS A CW IMMUNE EW DETECTOR MODULE THAT OPERATES FROM 8.0 TO 18.0 GHz. THIS MODEL FEATURES AN INTERNAL SWITCH USED TO SWITCH BETWEEN THE BIT IN AND RF IN WITH INPUT BLANKING ON BOTH PORTS. IN ADDITION, AN RF OUTPUT PORT IS PROVIDED WITH A GAIN OF 33 dB MINIMUM. THE VIDEO OUTPUT IS DESIGNED TO DRIVE A 100 FT CABLE.

ZONE	REV.	DESCRIPTION	DATE	APPROVED
	A1	ORIGINAL RELEASE	12/12/2024	
	B1	ECN # 25-0217	7/22/2025	

RF SPECIFICATIONS:

- FREQUENCY RANGE: 8.0 GHz TO 18.0 GHz
- I/O VSWR: 2.3:1 MAX
- INPUT POWER MAX: 1 WATT CW, 100 WATT PEAK @ PW = 1 us & 1% DUTY
- SWITCH MODE: (1) RF INPUT, (2) BIT, (3) CHOP
- ISOLATION: 60 dB MIN ALL PORTS
- SWITCHING SPEED: 100 ns MAX
- LINEAR RF GAIN: 42.5 dB MIN/47.5 dB MAX
- NOISE FIGURE: 6.5 dB MAX
- FREQUENCY FLATNESS: ±2.5 dB
- 1 dB COMPRESSION: +10 dBm MIN
- SATURATED POWER: +20 dBm MAX
- SECOND HARMONIC: -10 dBc MIN
- THIRD HARMONIC: -20 dBc NOM

VIDEO OUTPUT SPECIFICATIONS

- TSS: -71 dBm
- DYNAMIC RANGE: -65 TO 0 dBm
- LOG SLOPE: 70 mV/dB ± 3 mV/dB
- LOG LINEARITY: ±1.0 dB MAX
- LOG ACCURACY @ 25°C: ±1.75 dB MAX
- ABSOLUTE LOG ACCURACY: ±2.0 dB MAX
- DC OFFSET: ± 70 mV
- RISE TIME: 28 ns MAX (10-90% TESTED FROM -50 TO 0 dBm)
28 ns MAX (10-90% FULL DYNAMIC RANGE GUARANTEED)
- FALL TIME: 300 ns MAX (10-90% TESTED FROM -50 TO 0 dBm)
300 ns MAX (10-90% FULL DYNAMIC RANGE GUARANTEED)
- SETTling TIME: 50 ns MAX (FROM 10% TO WITHIN 70 mV OF FINAL VALUE @ -40 & -10 dBm)
- RECOVERY TIME: 1 us MAX (FROM 90% OF A -5 dBm, 100 us PULSE TO WITHIN ±1.5 dB OF BASELINE)
WITHOUT AMPLITUDE LOSS OF A FOLLOWING -65 dBm, 100 ns PULSE
- VIDEO FREQUENCY FLATNESS: ±1.75 dB MAX @ 25°C
- PULSE WIDTH PROCESS RANGE: 100 ns TO 100 us
- VIDEO OUTPUT LOAD IMPEDANCE: 95±1 OHMS
- VIDEO OUTPUT @ -65 dBm: 320±123 mV FOR ALL FREQUENCIES
- VIDEO OUTPUT DRIVE CAPABILITY: DRIVING 100 ft RG180 INTO 95 OHMS LOAD
- PULSE DENSITY CAPABILITY: 10% DUTY @ 100 ns PW, 70% DUTY @ 100 us PW
NO PULSE AMPLITUDE LOSS
- NOISE LEVEL: 25 mV RMS MAX
- PULSE DROOP @ -65 dBm: 70 mV MAX
- PROPAGATION DELAY: 50 ns MAX FROM 50% RF TO 10% VIDEO
- CW IMMUNE POWER: TSS TO -40 dBm
- BASELINE SHIFT: 200 mV MAX @ -40 dBm CW
- PULSE AMPLITUDE LOSS WITH PULSE POWER = -30 dBm
@ CW POWER = -50 dBm, NO LOSS
@ CW POWER = -40 dBm, 2 dB LOSS MAX
- CW IMMUNE TIME @ CW = -40 dBm: 4 ms MAX
- CW RECOVERY TIME @ CW = -40 dBm: 120 us MAX
- DC POWER: ±15V ±5% @ 0.7A MAX FOR +15V
0.2A MAX FOR -15V
- RIPPLE DC TO 10 MHz: 100 mV MAX
- CONNECTORS:
RF & VIDEO: SMA FEMALE
DC POWER & CONTROL: 9 PIN MICRO D-SUB FEMALE

ENVIRONMENTAL RATINGS / E.S.S.:

(ESS TEST PERFORMED 100%, REPORT PROVIDED FOR 1 UNIT PER LOT)

- MTBF: 5000H @ 50°C
- STABILIZATION BAKE: 24 HOURS @ +85°C
- THERMAL SHOCK: -10°C TO +85°C, 10 CYCLES 1 HOUR DWELL TIME AT EACH TEMP,
RATE OF TEMP CHANGE 15°C/MIN
- RANDOM VIBRATION: 20 Hz TO 2000 Hz, RANDOM 16.8 GRMS IN ALL 3 AXIS FOR 15 MINUTES MIN.
- BURN IN: 48 HOURS @ +85°C DC POWER ON
- OPERATING TEMPERATURE: -10°C TO +85°C
- FINISH: GRAY PAINT, NO PAINT ON MOUNTING SURFACE

NOTE: SPECIFICATIONS WILL VARY OVER TEMPERATURE
NOTE: THE ABOVE SPECIFICATIONS ARE SUBJECT TO CHANGE OR REVISION

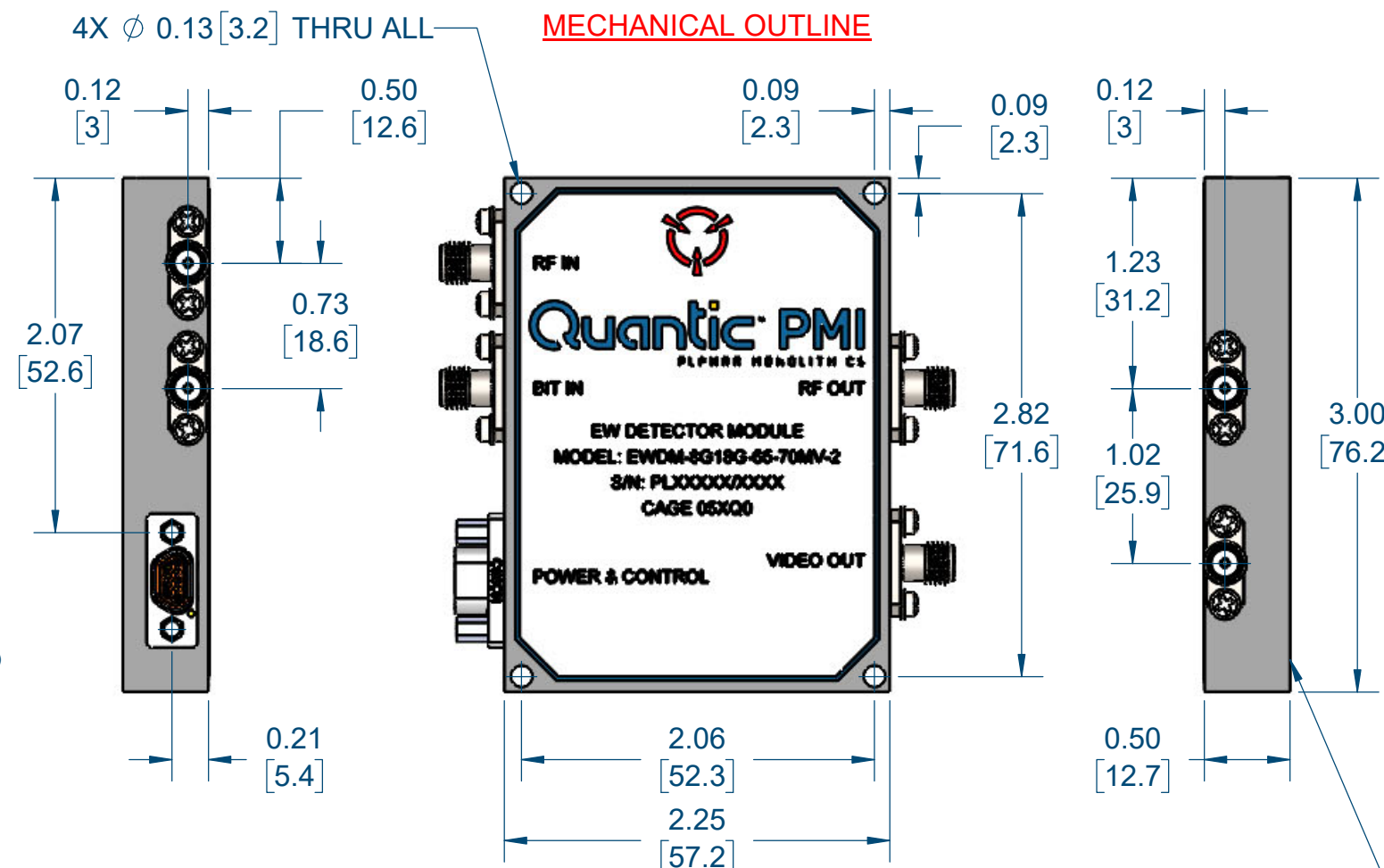

NO PAINT ON MOUNTING SURFACE

FUNCTIONAL BLOCK DIAGRAM

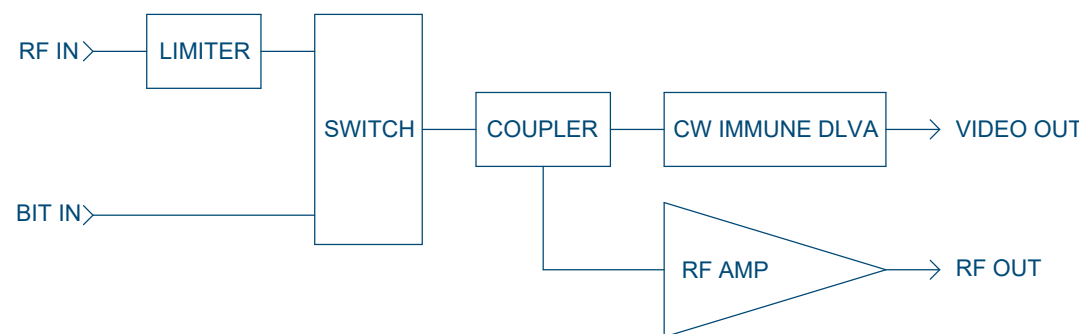

MICRO-D CONNECTOR PINS	
PIN NO.	FUNCTION
1	+15VDC
2	GND
3	NC
4	SW CONTROL TTL 1
5	SW CONTROL TTL 2
6	+15VDC
7	-15 VDC
8	-15VDC
9	GND

SWITCH CONTROL TTL LOGIC TABLE		
COMMAND MODES	PIN 4	PIN 5
RF INPUT MODE	TTL LOW	TTL LOW
BIT INPUT MODE	TTL HIGH	TTL LOW
RF INPUT CHOP	TTL LOW	TTL HIGH
BIT INPUT CHOP	TTL HIGH	TTL HIGH

PMI CONFIDENTIAL AND PROPRIETARY

<p>UNLESS OTHERWISE SPECIFIED DIMENSIONS ARE IN INCHES TOLERANCES ARE: FRACTIONS DECIMALS ANGLES ± .XX ± 0.02 ± XXX ± 0.01</p>		<p>APPROVALS</p> <p>DATE</p> <p>12/12/2024</p>	<p>7309-A GROVE ROAD FREDERICK MARYLAND 21704 USA TEL: (301) 662-5019, FAX: (301) 662-1731 WEB: WWW.QUANTICPMI.COM, EMAIL: SALES@QUANTICPMI.COM ISO 9001 CERTIFIED</p>
<p>DRAWN J ESCANO</p> <p>REISSUED</p>	<p>TITLE OUTLINE EWDM-8G18G-65-70MV-2</p>	<p>SIZE B</p> <p>FSCM NO. 05XQ0</p> <p>DWG NO. 27050140</p>	<p>REV. B1</p>
<p>SCALE 1:1</p>		<p>SHEET 1 OF 1</p>	