

ZONE	REV.	DESCRIPTION	DATE	APPROVED
	A1	ORIGINAL RELEASE	9/6/2025	

DESCRIPTION:

PMI MODEL: BPF-220M280M-60M-SFF IS A BANDPASS FILTER WITH SMA FEMALE CONNECTORS IN/ OUT. THIS UNIT HAS A PASSBAND FREQUENCY FROM 220 MHz TO 280 MHz.

SPECIFICATIONS:

- PASSBAND FREQUENCY:..... 220 MHz TO 280 MHz
- BANDWIDTH (-3 dB):..... 60 MHz MIN.
- INSERTION LOSS @ 250 MHz (F₀):..... 2 dB MAX
- VSWR:..... 1.5:1 MAX
- REJECTION @ 200 MHz:..... 40 dB MIN.
- REJECTION @ 300 MHz:..... 40 dB MIN.
- INPUT POWER:..... 1 W MAX
- CONNECTORS:..... SMA FEMALE
- FINISH:..... PAINTED BLUE

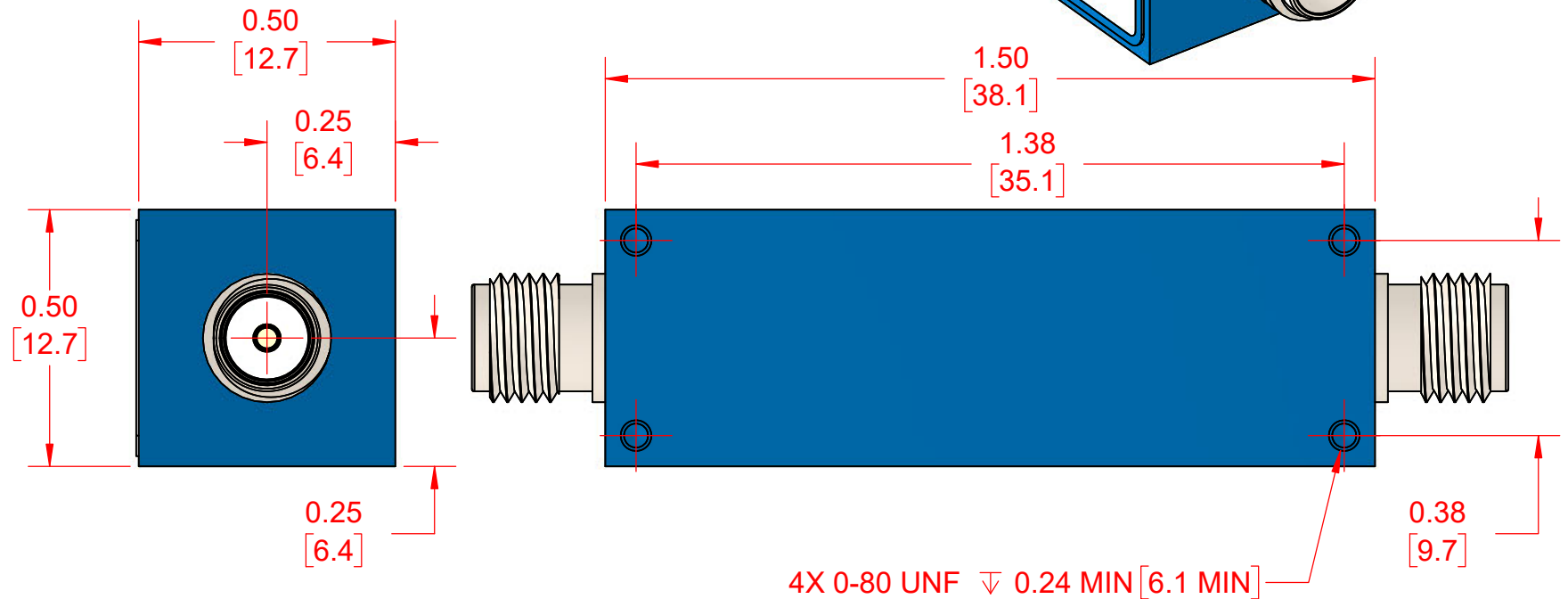
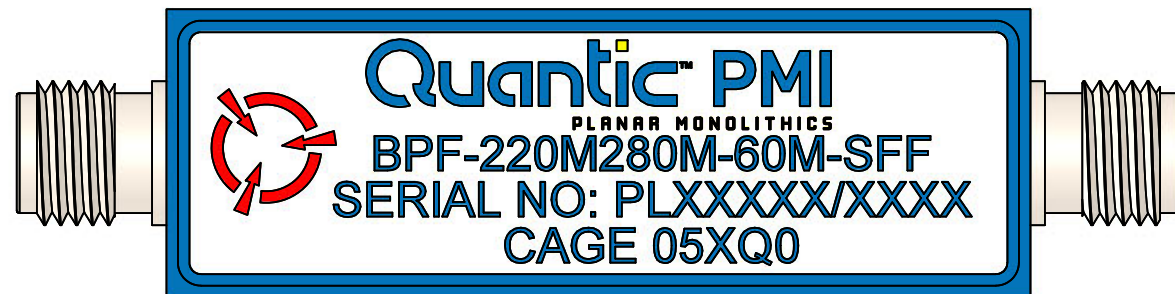
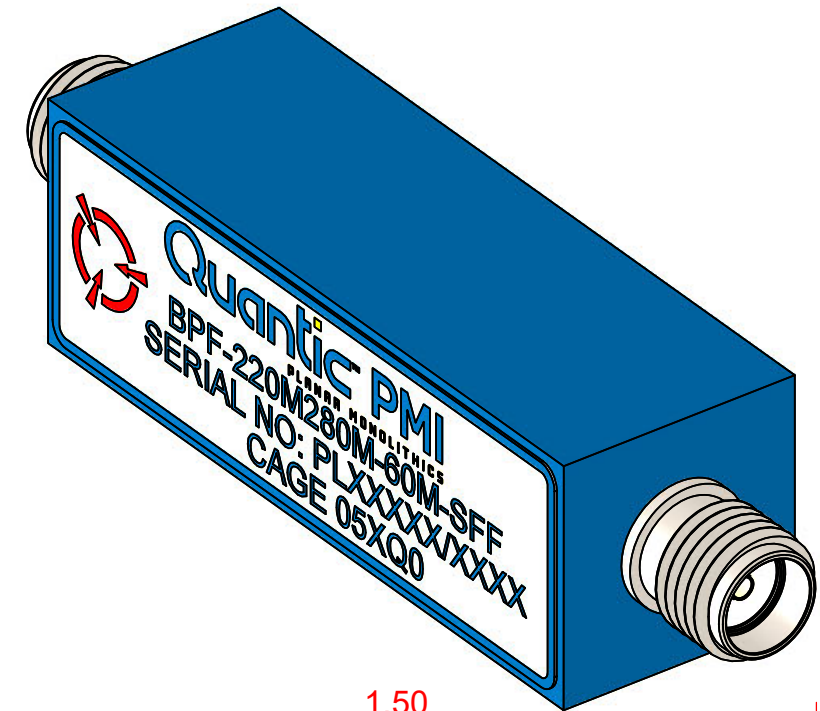

ENVIRONMENTAL RATINGS:

- TEMPERATURE:..... -55°C TO +85°C (OPERATING)
-65°C TO +125°C (STORAGE)
- HUMIDITY:..... MIL-STD-202, METHOD 103B COND. B
- SHOCK:..... MIL-STD-202, METHOD 213B COND. B
- VIBRATION:..... MIL-STD-202, METHOD 204D COND. B
- ALTITUDE:..... MIL-STD-202, METHOD 105C COND. B
- TEMPERATURE CYCLE:..... MIL-STD-202, METHOD 107D COND. A

NOTE: SPECIFICATIONS WILL VARY OVER TEMPERATURE
NOTE: THE ABOVE SPECIFICATIONS ARE SUBJECT TO CHANGE OR REVISION

PMI CONFIDENTIAL AND PROPRIETARY

APPROVALS DRAWN V. PRATAP REDRAWN ISSUED		DATE		Quantic PMI PLANAR MONOLITHICS 7309-A GROVE ROAD FREDERICK MARYLAND 21704 USA TEL: (301) 662-5019, FAX: (301) 662-1731 WEB: WWW.QUANTICPMI.COM, EMAIL: SALES@QUANTICPMI.COM ISO 9001 CERTIFIED	
		9/6/2025			
TITLE OUTLINE BPF-220M280M-60M-SFF				SIZE B	
UNLESS OTHERWISE SPECIFIED DIMENSIONS ARE IN INCHES TOLERANCES ARE: FRACTIONS DECIMALS ANGLES ± .XX ± 0.02 ± .XXX ± 0.01		FSCM NO. 05XQ0		DWG NO. 27052800	
SCALE 3:1				REV. A1	
				SHEET 1 OF 1	