

ZONE	REV.	DESCRIPTION	DATE	APPROVED
	A1	ORIGINAL RELEASE	11/5/2025	

DESCRIPTION:

PMI MODEL: BPF-2D2G2D29G-5W-SFF IS A BANDPASS FILTER WITH SMA FEMALE CONNECTORS IN/OUT. THIS UNIT HAS A PASSBAND FREQUENCY FROM 2.2 GHz TO 2.29 GHz.

SPECIFICATIONS:

- PASSBAND FREQUENCY:..... 2.2 GHz TO 2.29 GHz.
- INSERTION LOSS:..... 0.8 dB MAX
- RIPPLE:..... ±0.2 dB MAX
- VSWR:..... 1.3:1 MAX
- REJECTION @ DC TO 2.11 GHz:..... 40 dB MIN.
- REJECTION @ 2.4 GHz TO 5 GHz:..... 40 dB MIN.
- INPUT POWER:..... 5 W CW MAX
- CONNECTORS:..... SMA FEMALE
- FINISH:..... SILVER PLATED

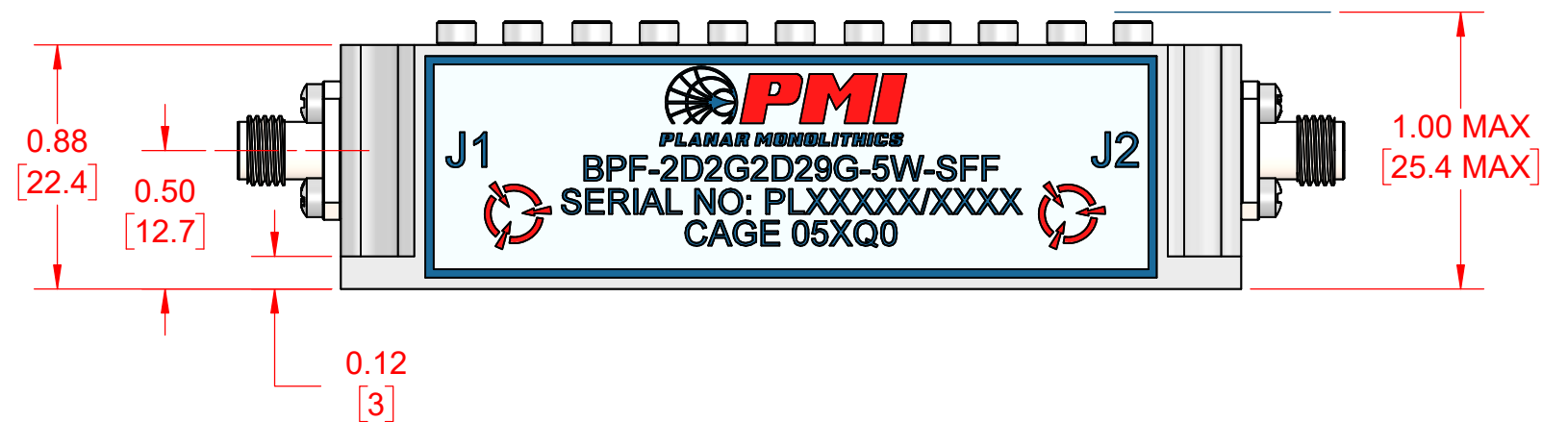
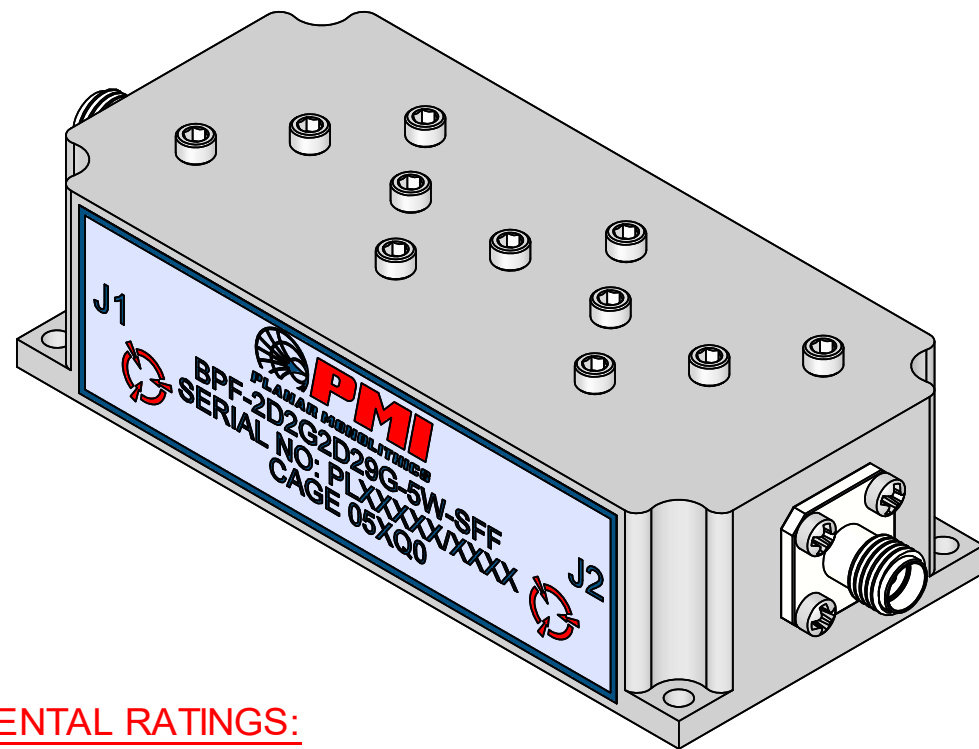
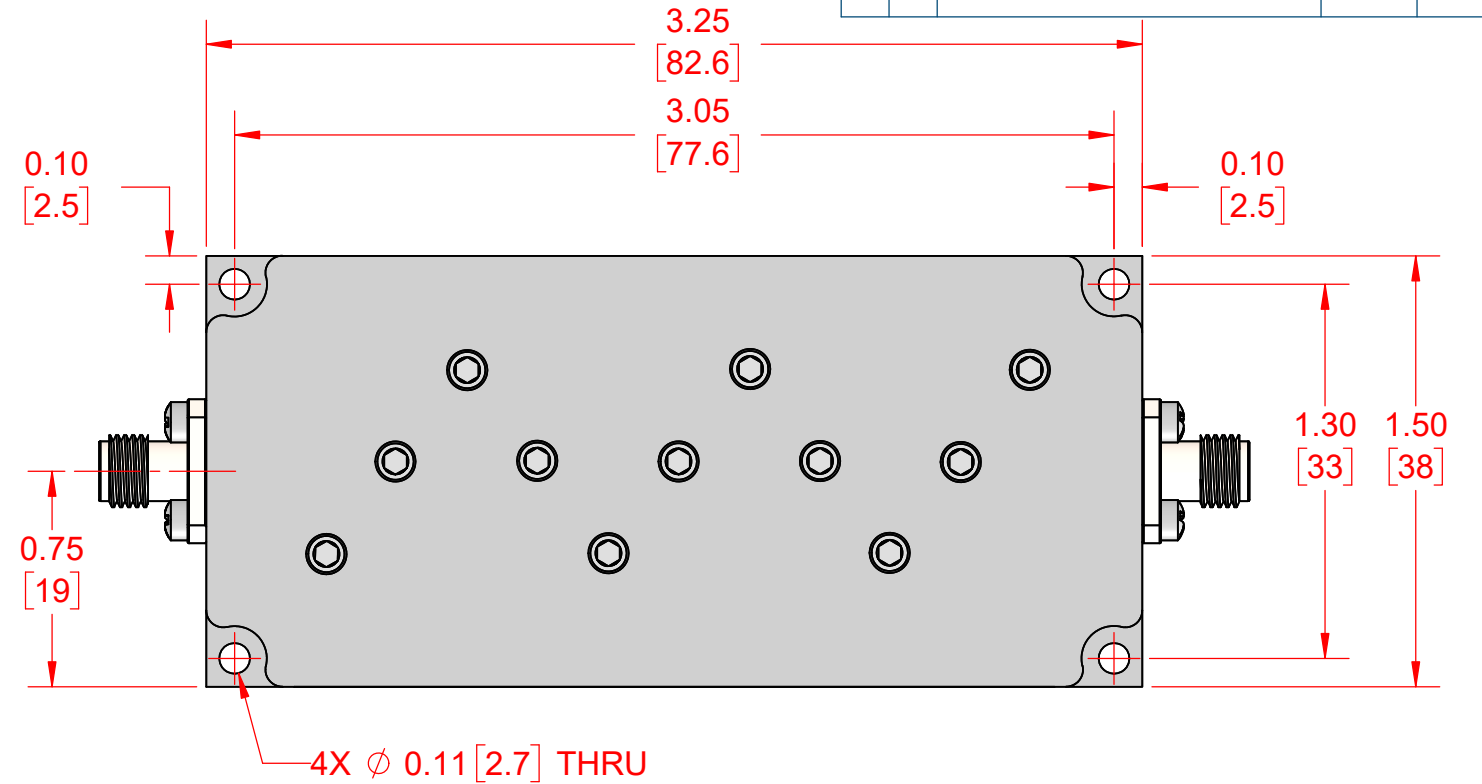

ENVIRONMENTAL RATINGS:

- TEMPERATURE:..... -24°C TO +60°C (OPERATING)
- HUMIDITY:..... MIL-STD-202, METHOD 103B COND. B
- SHOCK:..... MIL-STD-202, METHOD 213B COND. B
- VIBRATION:..... MIL-STD-202, METHOD 204D COND. B
- ALTITUDE:..... MIL-STD-202, METHOD 105C COND. B
- TEMPERATURE CYCLE:..... MIL-STD-202, METHOD 107D COND. A

NOTE: SPECIFICATIONS WILL VARY OVER TEMPERATURE
 NOTE: THE ABOVE SPECIFICATIONS ARE SUBJECT TO CHANGE OR REVISION

PMI CONFIDENTIAL AND PROPRIETARY

APPROVALS DRAWN V. PRATAP REDRAWN ISSUED		DATE 11/5/2025		 PMI PLANAR MONOLITHICS 7309-A GROVE ROAD FREDERICK, MARYLAND 21704 USA TEL: (301) 662-5019, FAX: (301) 662-1731 WEB: WWW.QUANTICPMI.COM, EMAIL: SALES@QUANTICPMI.COM ISO 9001 CERTIFIED	
		TITLE OUTLINE BPF-2D2G2D29G-5W-SFF			
UNLESS OTHERWISE SPECIFIED DIMENSIONS ARE IN INCHES TOLERANCES ARE: FRACTIONS DECIMALS ANGLES ± .XX ± 0.02 ± ± .XXX ± 0.01		SIZE B	FSCM NO. 05XQ0	DWG NO. 27053680	REV. A1
SCALE 3:2				SHEET 1 OF 1	