

DESCRIPTION:

PMI MODEL NUMBER PA-50-1D1G5D1G-SFF-X8 IS A CHASSIS CONTAINING 16 AMPLIFIERS WITH THE ABILITY TO INDIVIDUALLY TERMINATE UNUSED INPUT PORTS INTERNALLY INTO 50 OHMS. THE MINIMUM GAIN IS 50 dB WITH AN OUTPUT PSAT OF +33 dBm.

ZONE	REV.	DESCRIPTION	DATE	APPROVED
	A1	ORIGINAL RELEASE	9/9/2025	

SPECIFICATIONS:

- FREQUENCY RANGE:..... 0.5 TO 6 GHz
- NUMBER OF CHANNELS:..... 8 (8 INPUTS, 8 OUTPUTS)
- MAXIMUM INPUT POWER:..... +10 dBm
- GAIN (WITH 0 dB ATTENUATION):..... 50 dB NOMINAL
- PSAT:..... +33 dBm MINIMUM
- INPUT SPDT SWITCH:..... THROUGH OR INPUT TERMINATED INTO 50 OHM
- SPDT SWITCHING SPEED:..... 2 us TYP
- CONNECTORS:..... RF IN/ OUT: SMA FEMALE
- POWER SUPPLY:..... 100-240 VAC 50/60 Hz
- SIZE:..... 3U 19" RACK MOUNT CHASSIS 20" DEEP MAXIMUM
- FINISH:..... POWDER COATED BLUE

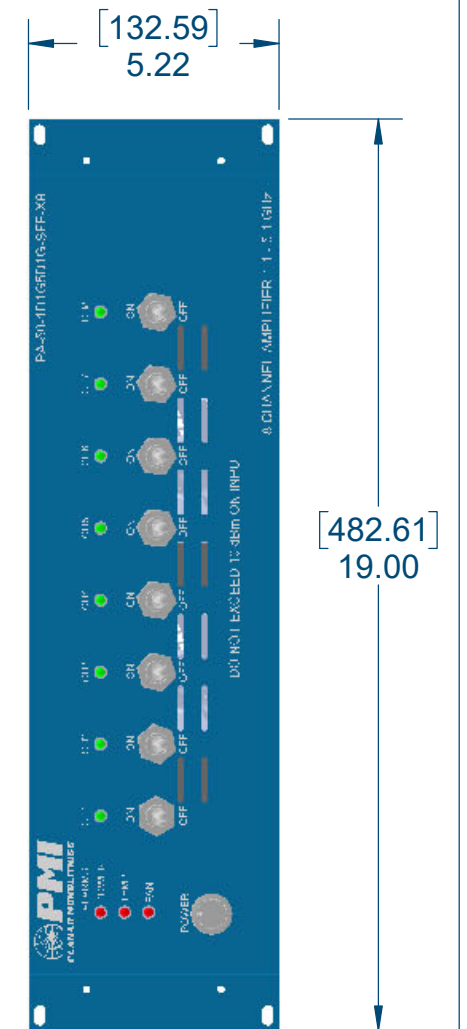
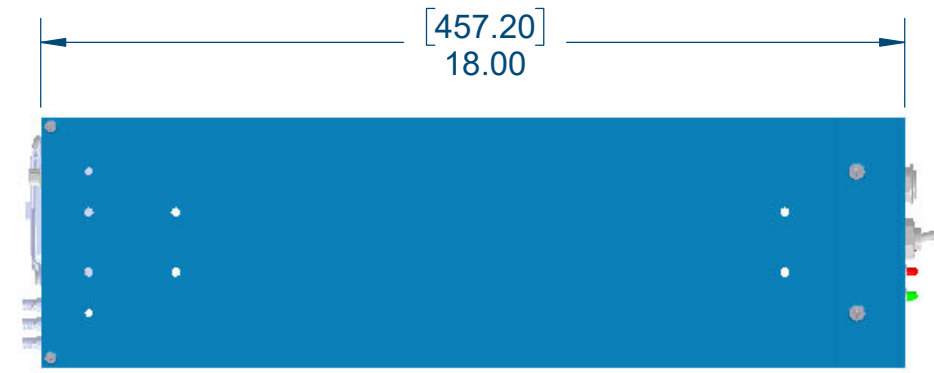

ENVIRONMENTAL RATINGS:

- TEMPERATURE:..... 10°C TO +30°C (OPERATING)

CONCEPTUAL BLOCK DIAGRAM:

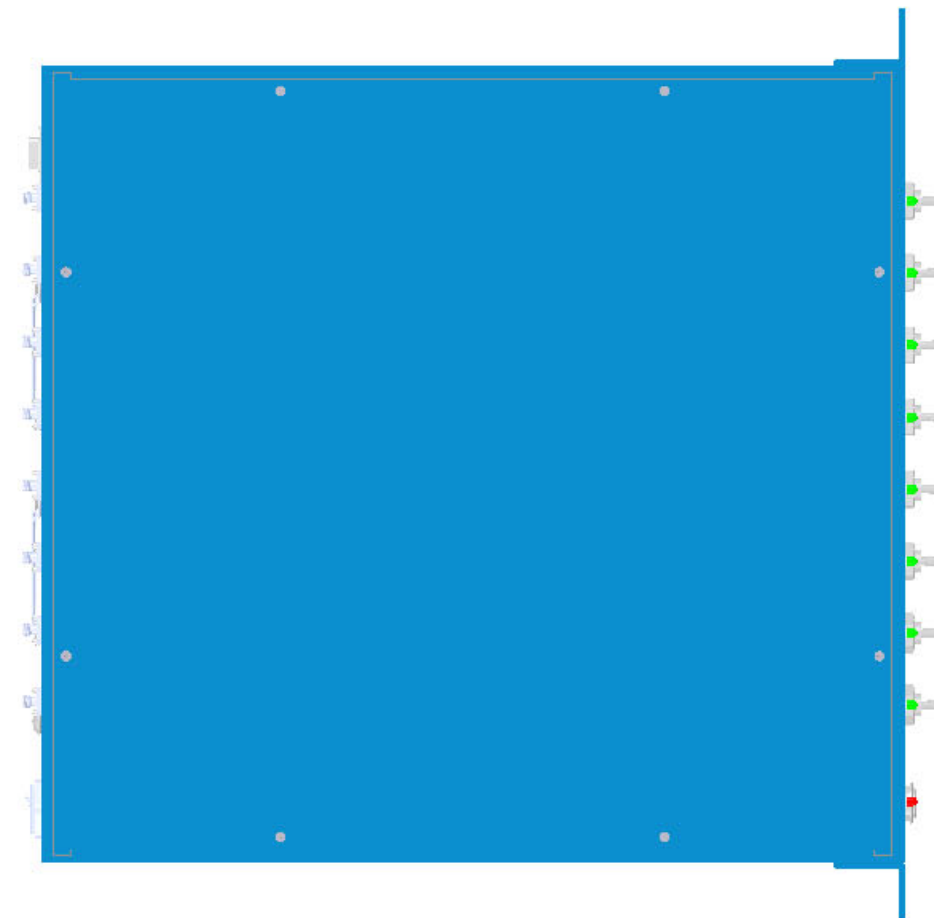
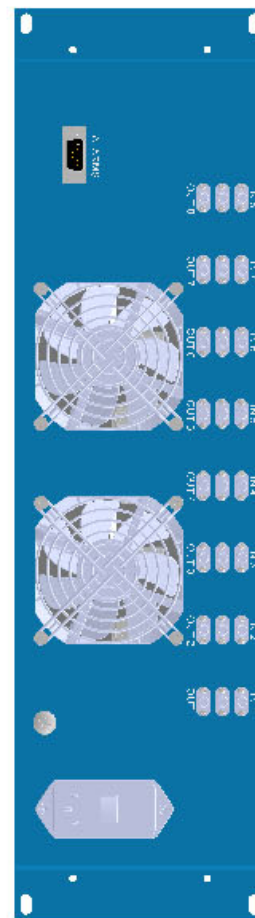
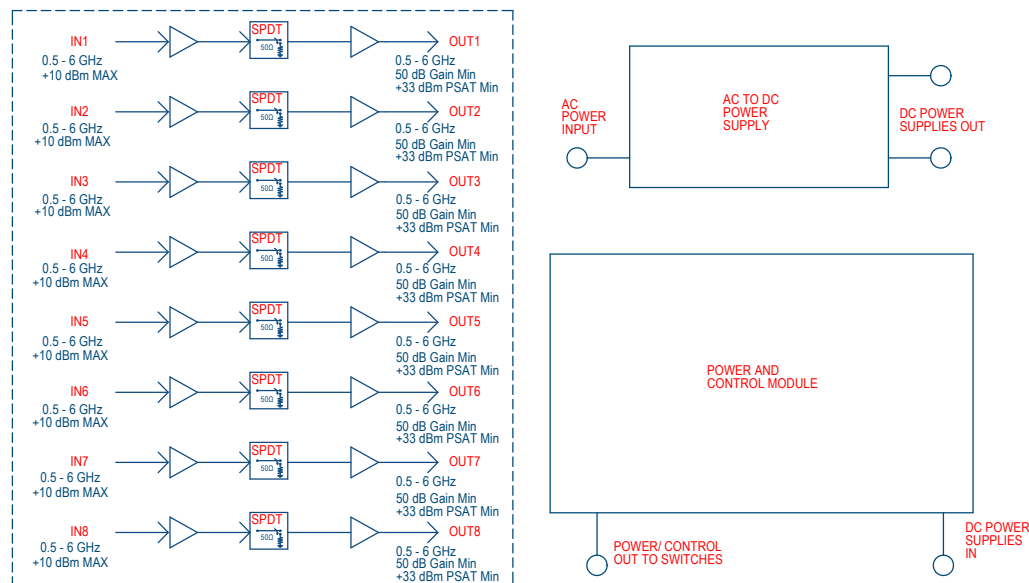

PMI CONFIDENTIAL AND PROPRIETARY

NOTE: SPECIFICATIONS WILL VARY OVER TEMPERATURE
 NOTE: THE ABOVE SPECIFICATIONS ARE SUBJECT TO CHANGE OR REVISION

UNLESS OTHERWISE SPECIFIED DIMENSIONS ARE IN INCHES TOLERANCES ARE: FRACTIONS DECIMALS ANGLES ± .XX ± 0.02 ± .XXX ± 0.01	APPROVALS	DATE	Quantic PMI PLANNAR MONOLITHICS 7309-A GROVE ROAD FREDERICK MARYLAND 21704 USA TEL: (301) 662-5019, FAX: (301) 662-1731 WEB: WWW.QUANTICPMI.COM, EMAIL: SALES@QUANTICPMI.COM ISO 9001 CERTIFIED		
	DRAWN M.LAULIS	9/9/2025	TITLE OUTLINE PA-50-1D1G5D1G-SFF-X8		
	REDRAWN		SIZE	FSCM NO.	DWG NO.
	ISSUED		B	05XQ0	27054380
			SCALE 1:8		REVISIONS A1
					SHEET 1 OF 1