

**DESCRIPTION:**

PMI model number 5CL10D14G-180-CD-SFF is a Combline filter with SMA female connectors in and out. All filters will be machined and silver plated to provide the highest possible Q.

REVISIONS				
ZONE	REV.	DESCRIPTION	DATE	APPROVED
	A1	ORIGINAL RELEASE	11/14/08	
	A2	ECN # 14-0112	7/22/14	

**SPECIFICATIONS:**

- CENTER FREQUENCY: . . . . . 10140 MHz Nom.
- 3dB BANDWIDTH: . . . . . 180 MHz Min.
- VSWR IN THE PASS BAND: . . . . . 1.5:1 MAX.
- INSERTION LOSS (PASSBAND) . . . . . 4 dB MAX.
- LOSS RIPPLE (PEAK TO PEAK) . . . . . 0.5 dB MAX.
- PHASE LINEARITY . . . . . ± 5° MAX.
- REJECTION -70 dB: . . . . . DC - 8000 MHz
- REJECTION -60 dB: . . . . . 8760 MHz
- REJECTION -60 dB: . . . . . 11520 - 12900 MHz
- REJECTION -50 dB: . . . . . 13000 - 17000 MHz
- CONNECTORS: . . . . . SMA FEMALE CONNECTORS
- SIZE . . . . . 1.90" (L) x 0.40" (W) x 0.40" (H)
- WEIGHT . . . . . 1 OZ. TYP.
- WEIGHT . . . . . GRAY EPOXY POLIMIDE COATING  
IAW MIL-C-22750, TYPE I OVER EPOXY  
POLIMIDE PRIMER IAW MIL-P-23377,  
TYPE I, CLASS 1 OR 3.

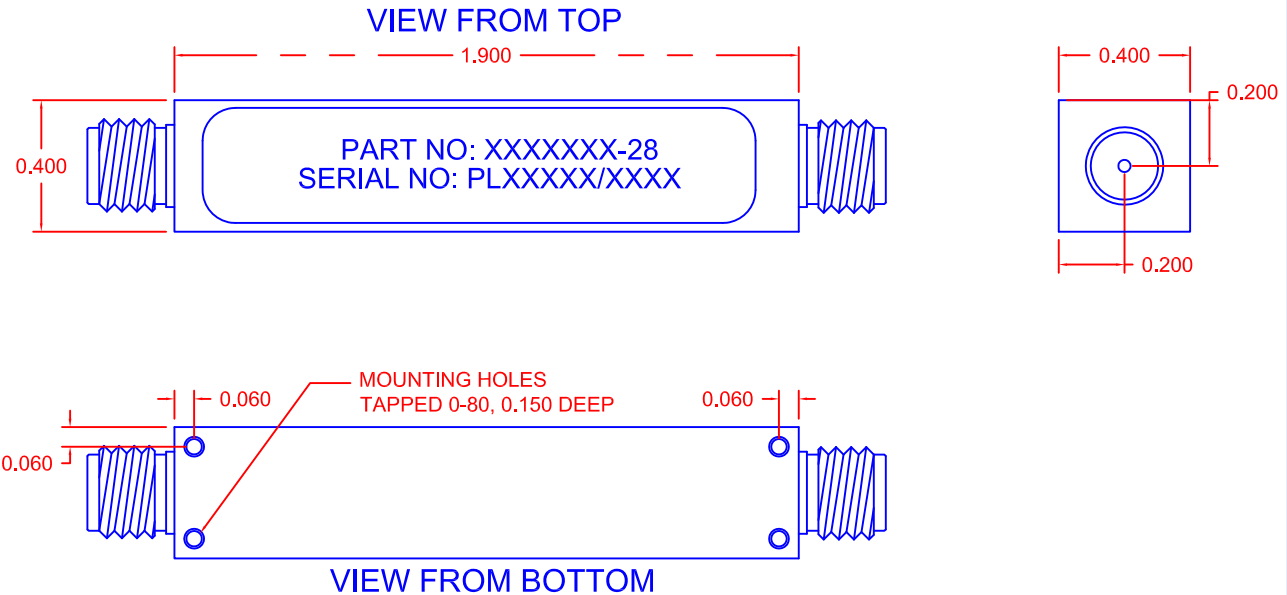

**PMI CONFIDENTIAL AND PROPRIETARY**

**ENVIRONMENTAL RATINGS:**

- TEMPERATURE: . . . . . -55°C TO +85°C (OPERATING)  
-65°C TO +125°C (STORAGE)
- HUMIDITY: . . . . . MIL-STD-202F, METHOD 103B COND. B
- SHOCK: . . . . . MIL-STD-202F, METHOD 213B COND. B
- VIBRATION: . . . . . MIL-STD-202F, METHOD 204D COND. B
- ALTITUDE: . . . . . MIL-STD-202F, METHOD 105C COND. B
- SALT FOG: . . . . . MIL-STD-202F, METHOD 107D COND. A
- FUNGUS: . . . . . MIL-STD-810C, METHOD 508.2
- TEMPERATURE CYCLE: . . . . . MIL-STD-202F, METHOD 107

NOTE: THE ABOVE SPECIFICATIONS ARE SUBJECT TO CHANGE OR REVISION

ALL DIMENSIONS ARE IN INCHES  
TOLERANCES:  
X.XX ±0.020  
X.XXX ±0.010

**PLANAR MONOLITHICS INDUSTRIES, INC.**  
 7311-F GROVE ROAD  
 FREDERICK, MARYLAND 21704 USA  
 TEL: 301-662-5019 FAX: 301-662-1731  
 WEBSITE: [www.pmi-rf.com](http://www.pmi-rf.com)  
 E-MAIL: [sales@pmi-rf.com](mailto:sales@pmi-rf.com)  
 ISO 9001 CERTIFIED



APPROVALS		DATE	TITLE			
DRAWN <i>S. PALAECIO</i>		11/14/08	PRODUCT FEATURE 5CL10D14G-180-CD-SFF			
CHECKED			SIZE A	FSCM NO. 05XQ0	DWG NO. 27009861	REV. A2
ISSUED			SCALE N: S		SHEET 1 OF 1	