

DESCRIPTION

PMI MODEL DRO-12D3G-CD-1 IS AN DIELECTRICALLY STABILIZED GaAs FET OSCILLATOR WITH THE FOLLWING SPECIFICATIONS

SPECIFICATIONS

- CENTER FREQUENCY: 12.3 GHz
- MECHANICAL TUNING FREQUENCY: ± 25 MHz
- OUTPUT POWER: +16 dBm Max. / +11 dBm Min.
- SPURIOUS: -55 dBc Min.
- HARMONICS: -20 dBc Min.
- PHASE NOISE (+25°C @ 10kHz): -75 dBc/Hz Min.
- FREQUENCY STABILITY: 12.3 MHz Max.
- PUSHING: 0.1 MHz/V Max.
- PULLING: ± 4 MHz Max @ VSWR
- DC SUPPLY: +15VDC ($\pm 5\%$) @ 150 mA Max
- CONNECTORS: SMA (F) / RFI SOLDER TERMINAL
- SIZE: 1.06" (L) X 1.63" (W) x 0.98" (H)
- FINISH: PAINTED GRAY
- WIEGHT: 2.4 Ounces Max

ENVIRONMENTAL RATINGS

- **TEMPERATURE:** -20°C TO +71°C (OPERATING)
-62°C TO +85°C (STORAGE)
- **HUMIDITY:** MIL-STD-202F, METHOD 103B COND. B
- **SHOCK:** MIL-STD-202F, METHOD 213B COND. B
- **VIBRATION:** MIL-STD-202F, METHOD 204D COND. B
- **TEMPERATURE CYCLE:** MIL-STD-202F, METHOD 107D COND. A

NOTE: SPECIFICATIONS WILL VARY OVER OPERATING TEMPERATURE
NOTE: THE ABOVE SPECIFICATIONS ARE SUBJECT TO CHANGE OR REVISION

ALL DIMENSIONS ARE IN INCHES
TOLERANCES:
X.XX ± 0.020
X.XXX ± 0.010
WEIGHT = 2.1 OZ

REVISIONS				
ZONE	REV.	DESCRIPTION	DATE	APPROVED
	1	ORIGINAL RELEASE	10/14/13	
	A1	ECN # 14-0015	02/01/14	

MECHANICAL OUTLINE

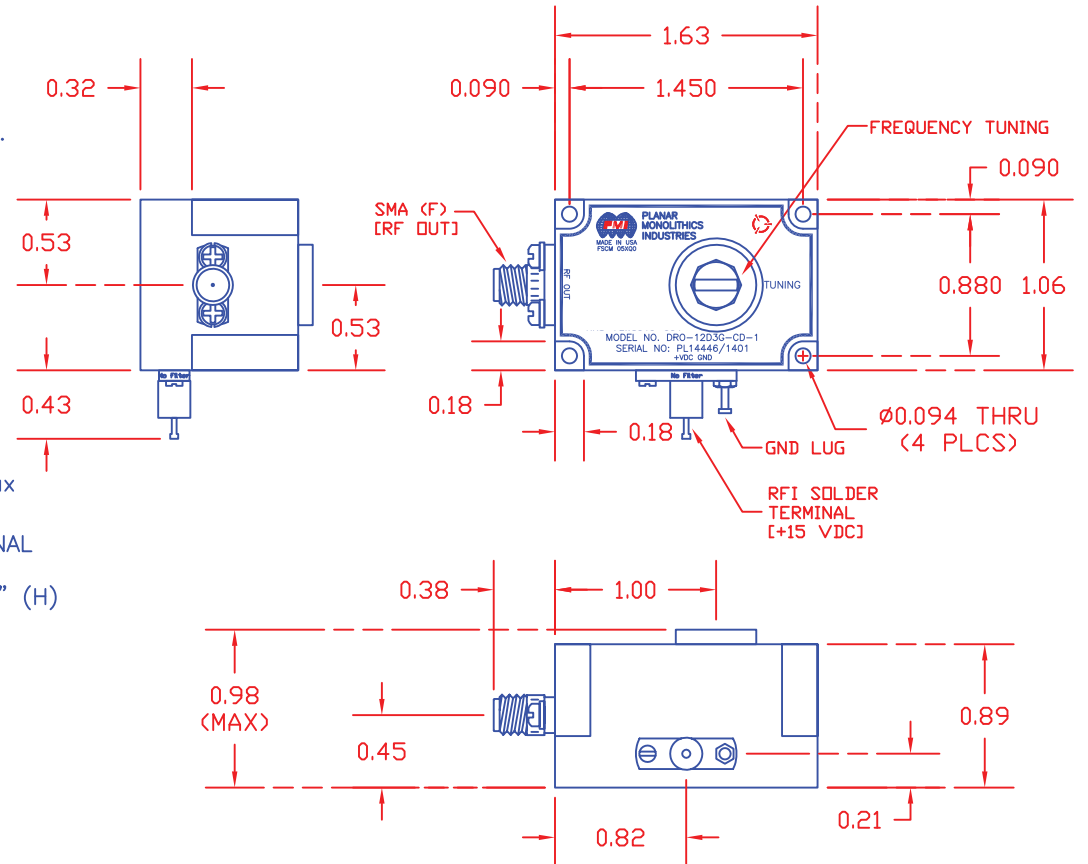

PMI CONFIDENTIAL AND PROPRIETARY

PLANAR MONOLITHICS INDUSTRIES, INC.

7311-F GROVE ROAD
FREDERICK, MARYLAND 21704 USA
TEL: 301-662-5019 FAX: 301-662-1731
WEBSITE: www.pmi-rf.com
E-MAIL: sales@pmi-rf.com
ISO 9001 CERTIFIED



APPROVALS		DATE	TITLE			
DRAWN <i>AMS</i>		10/14/13	PRODUCT FEATURE DRO-12D3G-CD-1			
CHECKED			SIZE	FSCM NO.	DWG NO.	REV.
ISSUED			A	05XQ0	27021391	A1
			SCALE	N:S		SHEET 1 OF 1