

# Characterization of an Evans Tantalum Hybrid Capacitor THQA2016502 – 5 mF/ 16 Volts

David Čespiva

David. A. Evans

## Brief Description of the Capacitor

The tantalum Hybrid capacitor combines an anode from a wet slug tantalum electrolytic capacitor with a ruthenium oxide based cathode from a redox electrochemical capacitor. The working electrolyte is 38% solution of sulfuric acid in water. The capacitor is enclosed in hermetic tantalum case. For better understanding see the fig. 1. Dimensions are in inches. Ruthenium oxide which forms the cathode of the capacitor is deposited on thin tantalum foils facing the pressed and sintered anode pellet. For parameters of the capacitor, see the tables below.

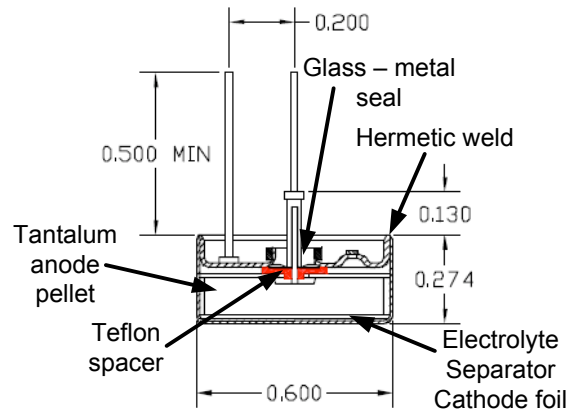

*Fig. 1: Construction of the tantalum Hybrid capacitor THQA2016502.*

Table 1: Parameters of the tantalum Hybrid capacitor THQA2016502 (1).

Parameter	Symbol	Value	Unit
Rated capacitance	$C_R$	5	mF
Rated voltage	$U_R$	16	V
Weight	m	8	g
Diameter x Length	D x L	1.5 x 0.6	cm
Energy*	E	0.64	J
Specific energy*	$E_{Spec}$	0.61	J/cm <sup>3</sup>
Specific energy*	$E_{Spec}$	0.08	J/g

\*) Energy calculations are based on rated values.

Table 2: Parameters of the tantalum Hybrid capacitor THQA2016502 (2).

Parameter	Symbol	Value	Unit
DC capacitance**	$C_{DC}$	7.4	mF
AC capacitance at 120 Hz	$C_{AC}$	5.57	mF
Resistance (ESR) at 1 kHz	ESR	0.118	$\Omega$
Leakage current***	$I_{Leak}$	30.9	$\mu A$
Frequency of <b>-45° phase shift</b>	$f_{-45}$	213.2	Hz
Resonance frequency	$f_0$	49.7	kHz
Specific power****	$P_{Spec}$	542.4	W
Specific power density	-	511.7	W/cm <sup>3</sup>
Specific power density	-	67.8	W/g

- \*\*\*) DC capacitance is determined from constant current charging (5 mA).
- \*\*\*) Leakage current is measured after 15 minutes at rated voltage and room temperature.
- \*\*\*\*) Specific power is calculated using the following formula:

$$P_{Spec} = \frac{U_R^2}{4 * ESR};$$

where  $U_R$  is rated voltage of the capacitor and  $ESR$  is its equivalent series resistance.

### Electrical Impedance Spectroscopy (EIS)

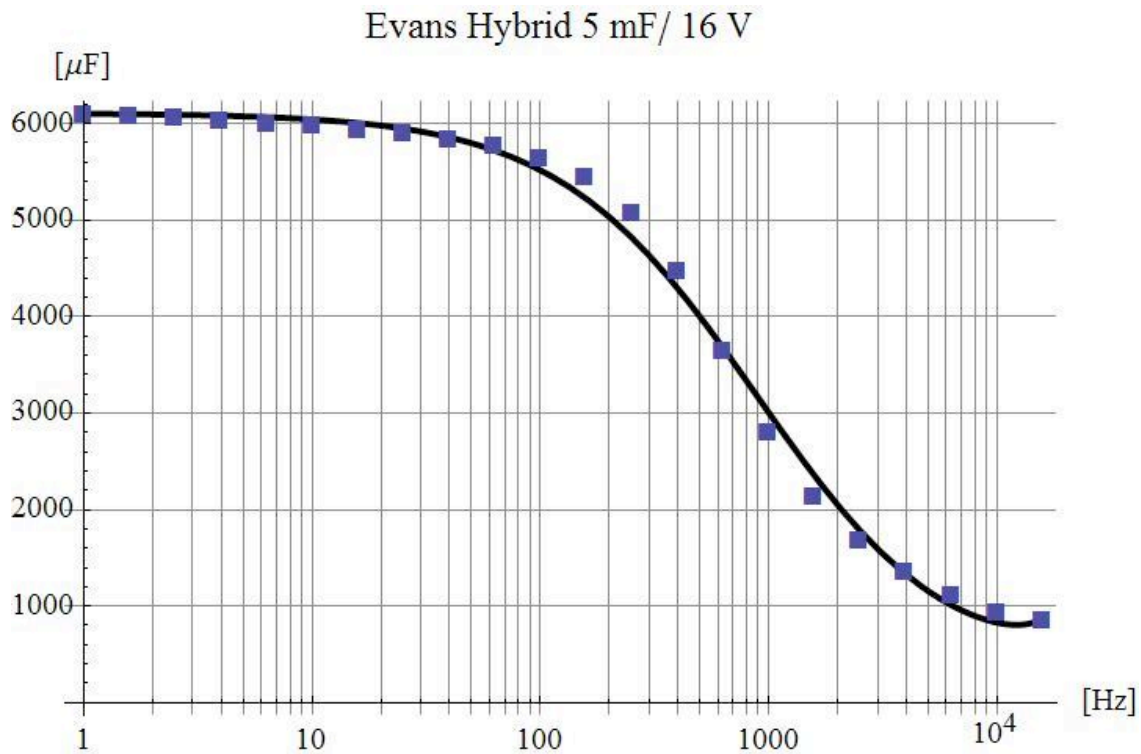

Fig. 2: Plot of capacitance vs. frequency. Blue markers show actually measured values while the black line is a result of mathematical modeling; the actual formula is given on the following page.

The formula describing dependence of capacitance on frequency:

$$Cap(f) = \frac{A}{B * f^2 + C * f + D};$$

where  $f$  is a frequency in Hz,  $A, B, C, D$  are constants which are specified for each particular capacitor; in case of our measured capacitor these are following:

- A = 1167.49,
- B =  $-8.4019 \times 10^{-9}$ ,
- C = 0.000205552,
- D = 0.19117.

When substituting previous constants into the formula we get the following:

$$Cap(f) = \frac{1167.49}{-8.4019 * 10^{-9} * f^2 + 0.000205552 * f + 0.19117};$$

frequency  $f$  is chosen from the range of 1 Hz to 15 000 Hz and the capacitance is in  $\mu\text{F}$ .

For frequency range from 1 Hz to 2 000 Hz it may be more accurate to use approximation by polynomials of 5<sup>th</sup> or 6<sup>th</sup> order, see fig. 3 below. (red = 5<sup>th</sup> order, green = 6<sup>th</sup> order)

$$Cap(f) = 6042.44 - 4.56681 * f + 0.00169964 * f^2 - 2.88164 * 10^{-7} * f^3 + 2.16824 * 10^{-11} * f^4 - 5.80593 * 10^{-16} * f^5$$

$$Cap(f) = 6062.77 - 4.95322 * f + 0.00224859 * f^2 - 5.32095 * 10^{-7} * f^3 + 6.63037 * 10^{-11} * f^4 - 4.0667 * 10^{-15} * f^5 + 9.52719 * 10^{-20} * f^6$$

In the above equations  $f$  stands for frequency in Hz and calculated capacitance is in  $\mu\text{F}$ .

Evans Hybrid 5 mF/ 16 V

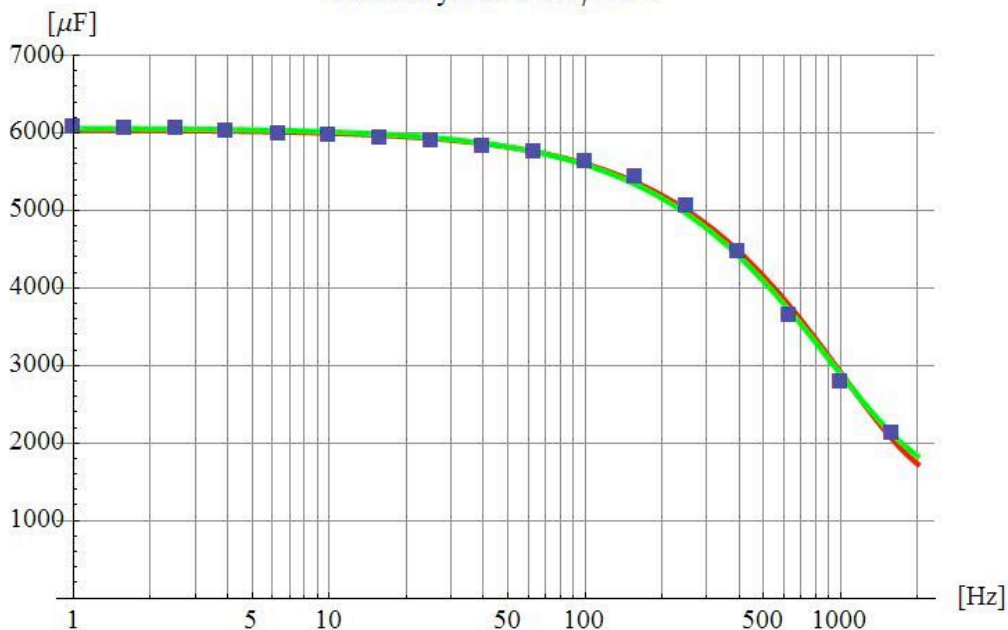

Fig. 3: Plot of capacitance vs. frequency. Approximation by polynomials.

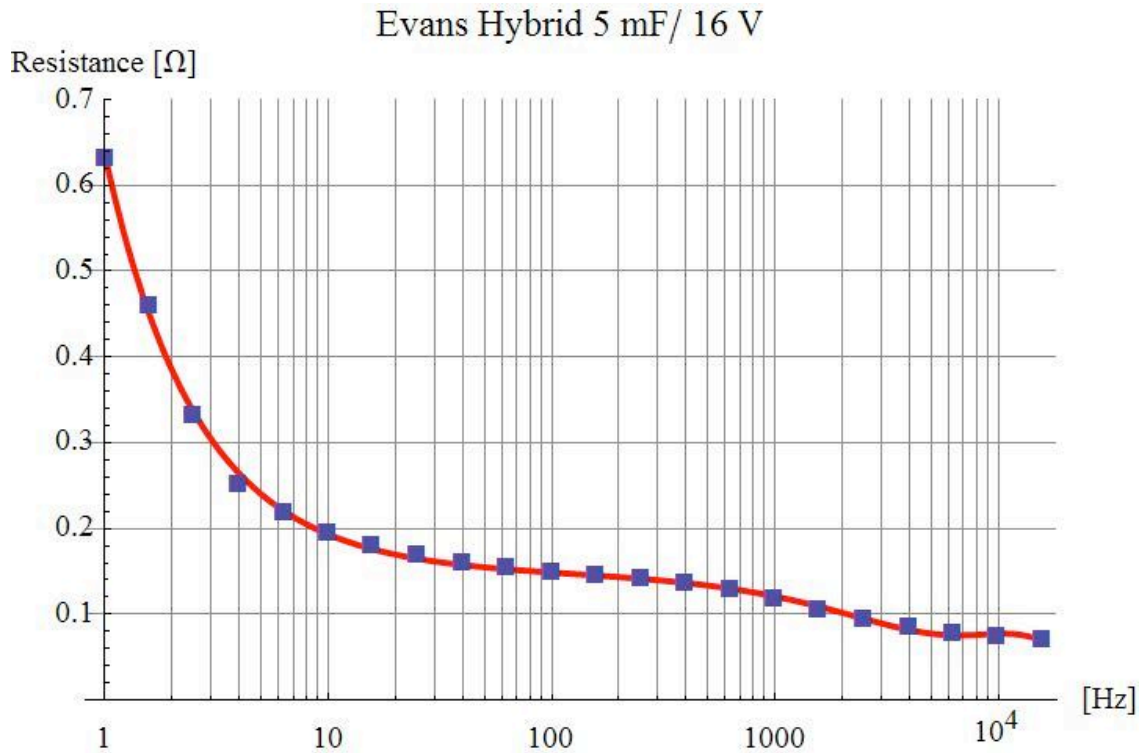

Fig. 4: Plot of ESR (resistance) vs. frequency and its approximation described below.

The formula describing dependence of equivalent series resistance (ESR, resistance) on frequency:

$$ESR(f) = \frac{A}{B + C * f} + D + E * f + F * f^2 + G * f^3 + H * f^4 + I * f^5;$$

where  $f$  is frequency in Hz,  $A, B, C, D, E, F, G, H, I$  are constants which are specified for each particular capacitor; in case of our measured capacitor these are following:

A = 9.41255,	D = 0.147229,	G = -3.54304*10 <sup>-13</sup> ,
B = -1.14464,	E = -0.0000314533,	H = 1.09253*10 <sup>-17</sup> ,
C = 20.469,	F = 5.01514*10 <sup>-9</sup> ,	I = -1.18578*10 <sup>-22</sup> .

When substituting previous constants into the formula we get the following:

$$ESR(f) = \frac{9.41255}{20.469 * f - 1.14464} + 0.147229 - 0.0000314533 * f +$$

$$+ 5.01514 * 10^{-9} * f^2 - 3.54304 * 10^{-13} * f^3 +$$

$$+ 1.09253 * 10^{-17} * f^4 - 1.18578 * 10^{-22} * f^5;$$

frequency  $f$  is chosen from range of 1 Hz to 15 000 Hz,  $ESR$  is in ohms.

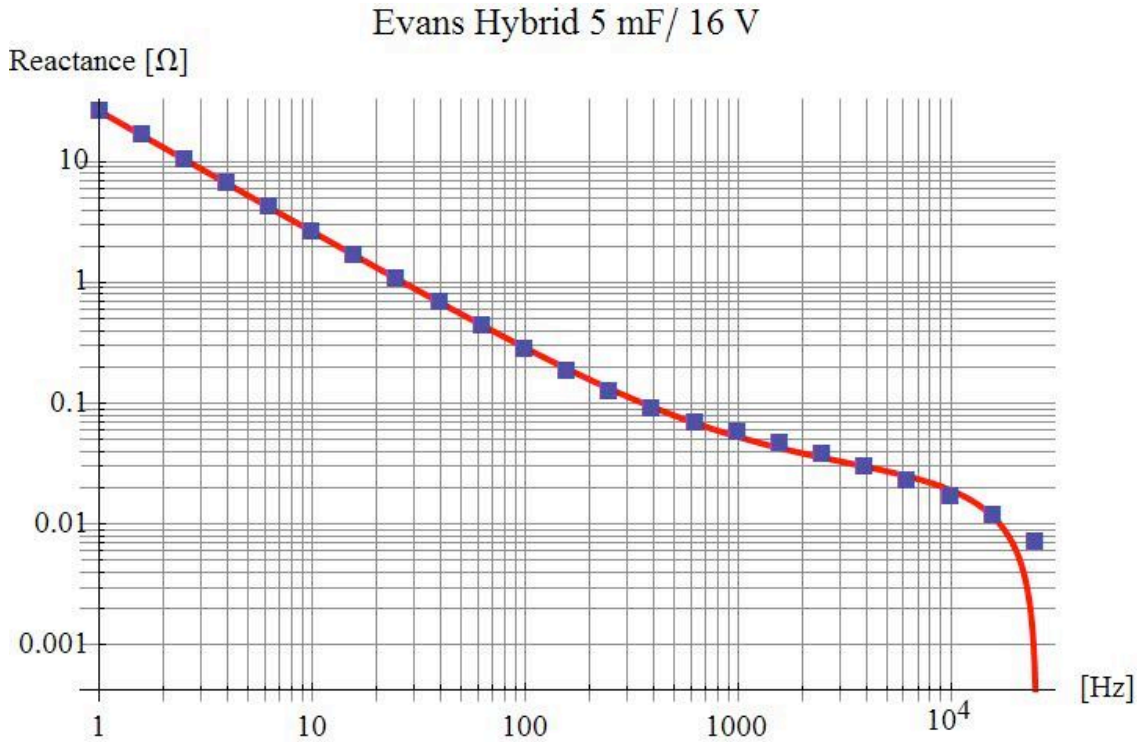

Fig. 5: Plot of reactance vs. frequency. The red line is an approximation by the function described below.

We have already mentioned a formula describing dependence of capacitance on frequency. Now we will use this formula to obtain a formula describing dependence of reactance on frequency. It is well known that the pure equation for capacitive reactance incorporates capacitance in it. It is very nice but it has a limitation. The formula works well as long as the capacitance is constant; BUT, as we have shown, the capacitance is strongly dependent on frequency due to porous anode used in construction of our Hybrid capacitor.

$$X = \frac{1}{2\pi f C_{ap}} \quad \text{becomes} \quad X = \frac{1}{2\pi f C_{ap}(f)}$$

We already know that for capacitance we can use a general formula as follows:

$$C_{ap}(f) = \frac{A}{B * f^2 + C * f + D}$$

Incorporating this formula into the formula for reactance we get the following:

$$X(f) = \frac{1}{2\pi f \frac{A}{B * f^2 + C * f + D}} = \frac{B * f^2 + C * f + D}{2\pi f A}$$

In the previous formula  $f$  stands for frequency in Hz and  $A, B, C, D$  are constants specific for each particular capacitor. In case of our measured capacitor these are:

- A = 1167.49,
- B =  $-8.4019 \times 10^{-9}$ ,
- C = 0.000205552,
- D = 0.19117.

The previous constants together with frequency in Hz gave us a capacitance in  $\mu\text{F}$ . In order to obtain a reactance in ohms we need to introduce a multiplier – in our case  $10^6$ . Then we can write the following:

$$X(f) = 10^6 \frac{B * f^2 + C * f + D}{2\pi f A}$$

After incorporating the previously mentioned constants into the previous formula we get the following final equation describing dependence of reactance on frequency. See the red curve plotted on previous page.

$$X(f) = 0.0280213 + \frac{26.0607}{f} - 1.14537 * 10^{-6} * f;$$

$f$  stands for frequency in Hz, calculated reactance  $X$  is in ohms.

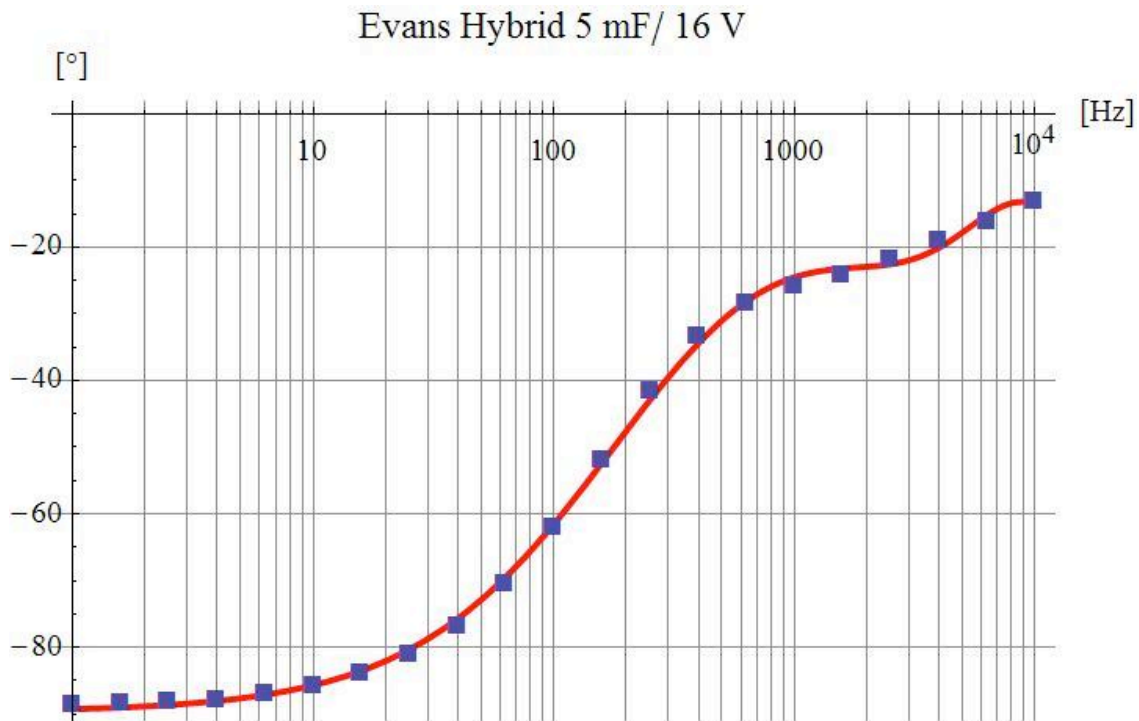

Fig. 6: Plot of phase angle vs. frequency. An ideal capacitor has a phase angle of  $-90^\circ$ .

The general formula describing dependence of phase angle on frequency:

$$\varphi(f) = \frac{A}{B + C * f} + D + E * f + F * f^2 + G * f^3 + H * f^4 + J * f^5 + K * f^6;$$

where  $f$  stands for frequency and  $A, B, C, D, E, F, G, H, J, K$  are constants specific for each particular capacitor. In the case of our measured capacitor these constants are as follows:

$A = 5.34566 * 10^4,$	$E = -0.0174016,$	$J = -1.06948 * 10^{-18},$
$B = -560.88,$	$F = 5.05024 * 10^{-6},$	$K = 1.08967 * 10^{-23}.$
$C = -2.55275,$	$G = -6.35507 * 10^{-10},$	
$D = 5.61447,$	$H = 3.83561 * 10^{-14},$	

Substituting previous constants into the general formula we get:

$$\varphi(f) = \frac{5.34566 * 10^4}{-560.88 - 2.55275 * f} + 5.61447 - 0.0174016 * f +$$

$$+ 5.05024 * 10^{-6} * f^2 - 6.35507 * 10^{-10} * f^3 +$$

$$+ 3.83561 * 10^{-14} * f^4 - 1.06948 * 10^{-18} * f^5 + 1.08967 * 10^{-23} * f^6;$$

where  $f$  is a frequency from 1 Hz to 10 000 Hz. Phase angle is measured in degrees.

A capacitor works efficiently if its phase angle is somewhere between  $-45^\circ$  and  $-90^\circ$ . With it on mind we can abandon the previous formula and we can approximate behavior of the capacitor by polynomial of 3<sup>rd</sup> order. Such a polynomial approximates dependence of phase angle on frequency in the said range of efficient operation.

$$\varphi(f) = -89.0566 + 0.335689 * f - 0.000716302 * f^2 + 5.32317 * 10^{-7} * f^3;$$

where  $f$  stands for a frequency from range of 1 Hz to 300 Hz for our particular capacitor under evaluation. Phase angle is measured in degrees. See the curve below.

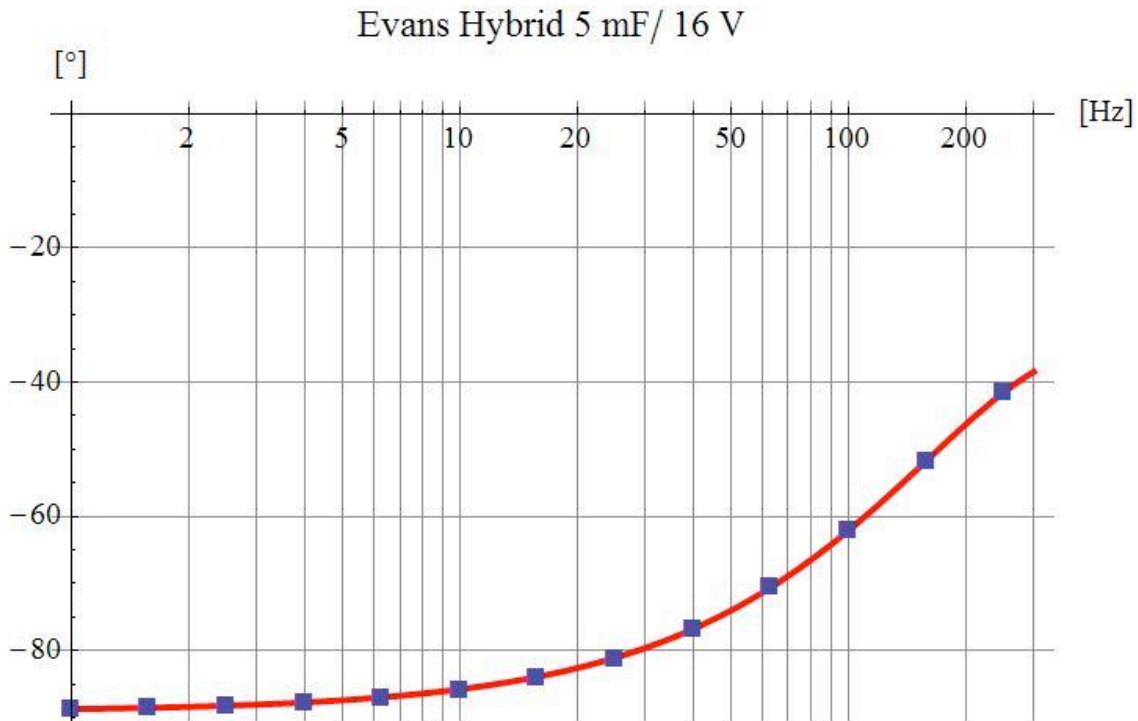

*Fig. 7: Plot of phase angle vs. frequency. Approximation by polynomial of 3<sup>rd</sup> order. Efficient mode of operation. An ideal capacitor has a phase angle of  $-90^\circ$ .*

Temperature Spectroscopy (TS)

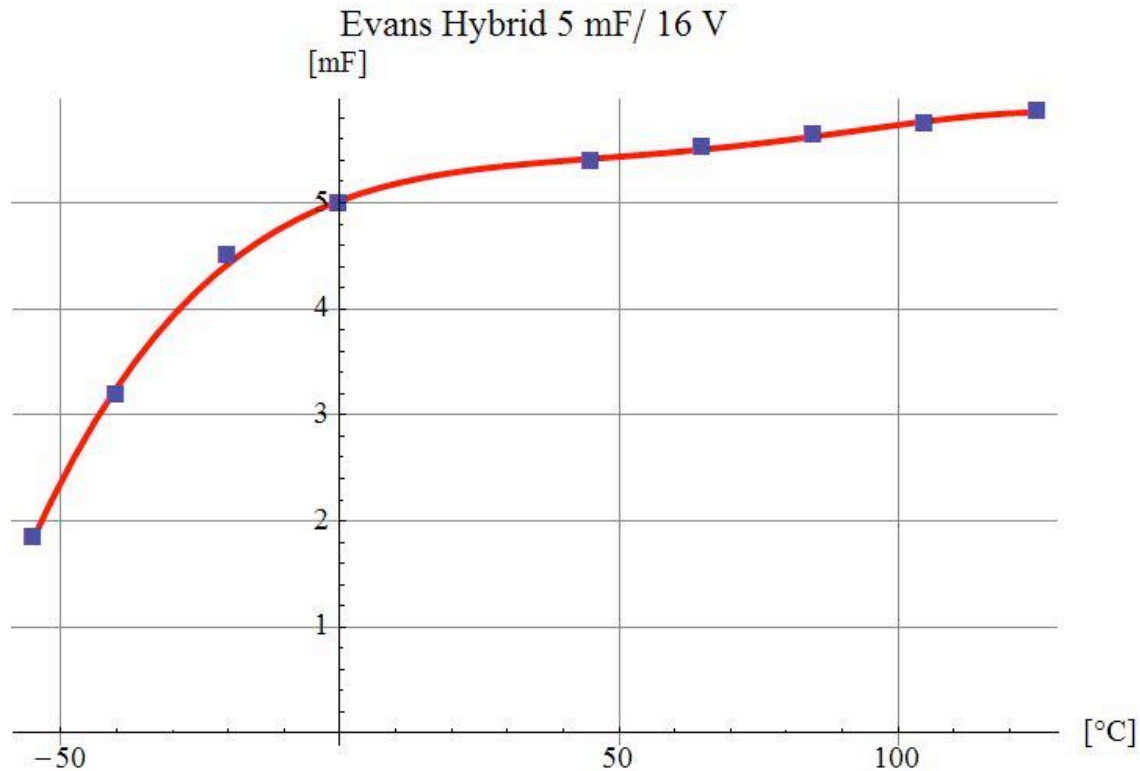

Fig. 8: Plot of capacitance vs. temperature.

A formula describing temperature dependence of capacitance for our particular capacitor is:

$$Cap(\vartheta) = 5.0218 + 0.0196408 * \vartheta - 0.000408064 * \vartheta^2 + 4.41422 * 10^{-6} * \vartheta^3 - 1.58473 * 10^{-8} * \vartheta^4;$$

where *Cap* is the capacitance in mF and  $\vartheta$  is temperature in °C. The capacitance was measured at 120 Hz with 0.5 VAC with no DC bias.

Now we can proceed to a temperature dependence of ESR (resistance) and loss factor (Tg. Delta). ESR was measured again at 120 Hz and loss factor is calculated using the following equation:

$$Tg.Delta = 2\pi * f * Cap * ESR;$$

Where *f* is frequency, in our case it is 120 Hz, *Cap* is a capacitance in F, *ESR* is a resistance in Ω. A formula describing temperature dependence of resistance is a polynomial of 6<sup>th</sup> order:

$$ESR(\vartheta) = 0.26833 - 0.00424503 * \vartheta + 0.0000789751 * \vartheta^2 - 1.7778 * 10^{-6} * \vartheta^3 + 2.88536 * 10^{-8} * \vartheta^4 - 2.30898 * 10^{-10} * \vartheta^5 + 6.84518 * 10^{-13} * \vartheta^6.$$

Temperature is again in °C. *ESR* is in Ω. See the plot on the following page.

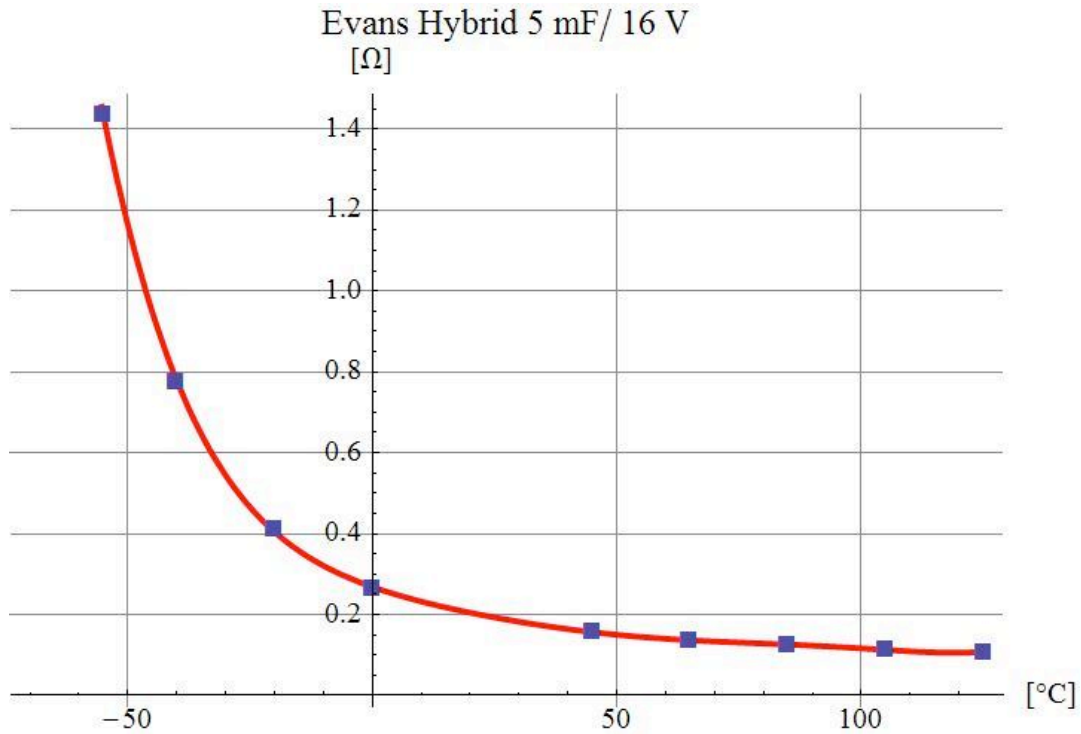

Fig. 9: Plot of ESR (resistance) vs. temperature for our particular capacitor. ESR decreases with an increase of temperature due to higher ionic mobility at higher temperatures.

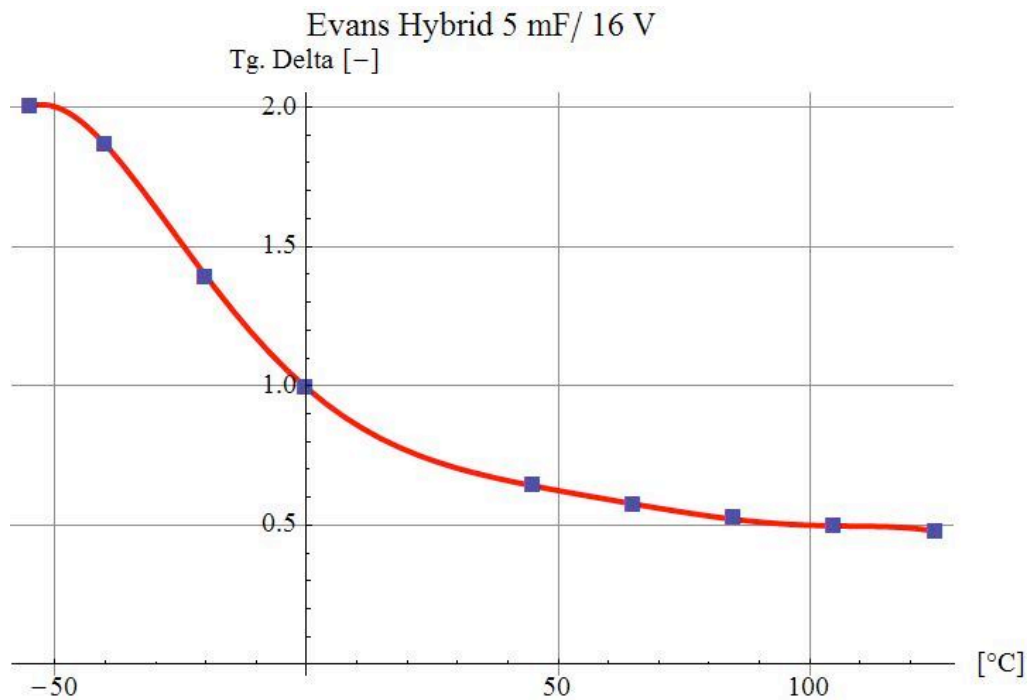

Fig. 10: Plot of Tg. Delta (loss factor) vs. temperature. See the following page for a formula.

A formula describing temperature dependence of loss factor (Tg. Delta) – again 6<sup>th</sup> order polynomial:

$$\begin{aligned} Tg. Delta (\vartheta) = & 0.992401 - 0.0155655 * \vartheta + 0.000235342 * \vartheta^2 - \\ & -4.20796 * 10^{-7} * \vartheta^3 - 3.90487 * 10^{-8} * \vartheta^4 + 4.55344 * 10^{-10} * \vartheta^5 - \\ & -1.51707 * 10^{-12} * \vartheta^6. \end{aligned}$$

Temperature is again in °C.

We used *Wolfram Mathematica*® software in this evaluation.