

Capstick® Capacitor
 Metallized Polyester Dielectric

CS11

Stacked Metallized
 Polyester Capacitor
 With -55°C to +125°C
 operating temperature range

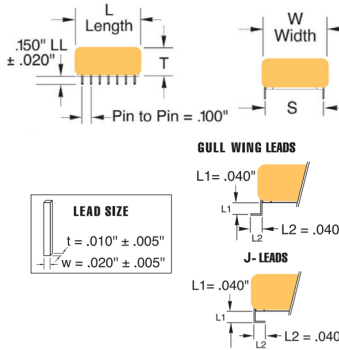

NEW

- High voltage ratings
- High ripple current ratings
- High capacitance density
- Surface-mount options available
- Ultra-low ESR/ESL
- Lightweight <25% of equivalent MLCC
- Low losses at high frequency
- Self-healing
- Rugged construction
- Made in U.S.A.

1200 VDC/630 VAC

PF Code	Value μF	W Max	T Max	L Max	S \pm .02 [5]	Typical ESR 500KHz m Ω	Max Ripple current 85°C 500KHz [ARMS]	Lead Configuration	Part No.
474	0,47	1.22(31.0)	0.57(14.5)	1.2 [30.5]	1.1 [27.5]	33	14,2	Thru-hole	474K1200CS11_
474	0,47	1.22(31.0)	0.57(14.5)	1.2 [30.5]	1.1 [27.5]	33	14,2	SMD GULL-WING	474K1200CS11G_
474	0,47	1.22(31.0)	0.57(14.5)	1.2 [30.5]	1.1 [27.5]	33	14,2	SMD J-Lead	474K1200CS11J_

1000 VDC/500 VAC

804	0.80	1.22(31.0)	0.39(9.9)	1.1 [27.5]	1.1 [27.5]	28	5,8	Thru-hole	804K1000CS11_
804	0.80	1.22(31.0)	0.39(9.9)	1.1 [27.5]	1.1 [27.5]	28	5,8	SMD GULL-WING	804K1000CS11G_
804	0.80	1.22(31.0)	0.39(9.9)	1.1 [27.5]	1.1 [27.5]	28	5,8	SMD J-Lead	804K1000CS11J_

Dimensions in inches, metric (mm) in parenthesis
 Tolerance: K (\pm 10%) standard, J (\pm 5%) available

RoHS part number information —
 No suffix indicates RoHS-6 compliant standard part number. RoHS-6 product does not contain five of the RoHS banned materials (Hg, CrVI, Cd, PBB and PBDE) in levels exceeding the industry defined limits. Component lead wires are plated with Sn / Pb and match conventional SnPb 1 assembly requirements.

For a RoHS-6 compliant part, add a -FA suffix. RoHS-6 product does not contain any of the six RoHS banned materials (Hg, CrVI, Cd, PBB, PBDE and Pb) in levels exceeding the industry defined limits. Component lead wires are plated with Sn.

Electrical	Performance	Physical
<p>Tolerance: Available in \pm 5%, 10% (standard), 20%</p> <p>Voltage Range: 1000, 1200 VDC</p> <p>Dissipation Factor: $\leq 1.0\%$ @ 25°C, 1KHz</p> <p>Insulation Resistance: 1000ΩF or 100GΩ, whichever is less at rated voltage and 25°C</p> <p>Dielectric Strength: 1.3 x RVDC, 2 seconds max.</p> <p>Self Inductance: 2nh to 6nh typical</p> <p>Temperature Range: -55°C to 125°C operating -55°C to 85°C @ rated DC voltage derate voltage 1.25% / °C above 85°C max operating temperature; 125°C</p>	<p>Accelerated DC Voltage Life Test: 1,000 Hours, 85°C, 1.25 x Rated VDC Δ C/C \leq 5% DF \leq 1.0%, 1KHz, 25°C IR \geq 1,000 Megohm x μF Need not exceed 1,000 Megohms</p> <p>Moisture Test: 85°C / 85% RH / 21 days Applied Voltage: zero bias Δ C/C \leq 7% DF \leq 1.0%, 1KHz, 25°C IR \geq 30% of initial limit</p> <p>Long Term Stability: After 2 years storage, standard environment Δ C/C \leq 2%</p>	<p>Vibration: Mil Std 202 Method 204D</p> <p>Solder Resistance: Thru-hole wave: 260°C, 5 Sec. Δ C/C \leq 2% SMD reflow: 220°C, 30 Sec. Δ C/C 2%</p> <p>Construction: Non-inductively constructed with metallized polyester dielectric (polyethylene terephthalate). Parallel plate-multilayer polymer (MLP) design.</p> <p>Electrode: Aluminum metallization</p> <p>Case: UL94V-0 rated epoxy coating</p> <p>Lead-Frame Material: Tinned Cu Alloy Lead-Frame</p> <p>Lead Spacing: 1.1" (27.5mm) spacing nominal 7 leads per side</p> <p>Marking: +P+ type, capacitance code, tolerance code, voltage and date code</p> <p>Packaging: Anti-static tube. SMD units are dry-packed with desiccant in a moisture barrier bag (MBB). Moisture Sensitivity Level (MSL): 4 per IPC/JEDEC J-ST-020; level indicated on package.</p>

Capstick® Capacitor
Metallized Polyester Dielectric

CS11

Electrical Characteristics 1000 VDC and 1200 VDC Ratings

Impedance Vs Frequency

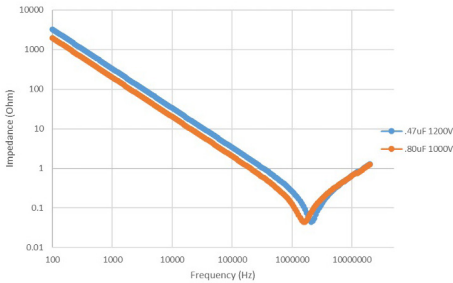

ESR Vs Frequency

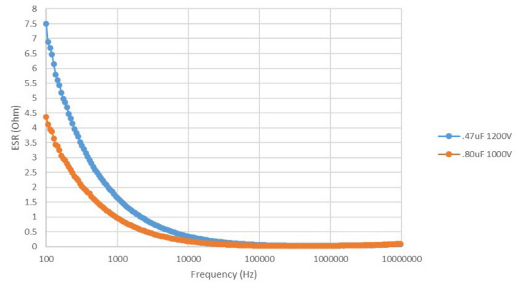

Ripple Current Limit Vs Frequency -55 to +85C

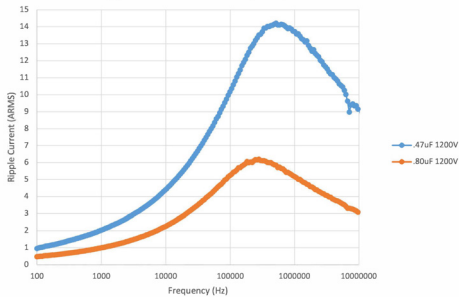

Maximum RMS Voltage Vs Frequency

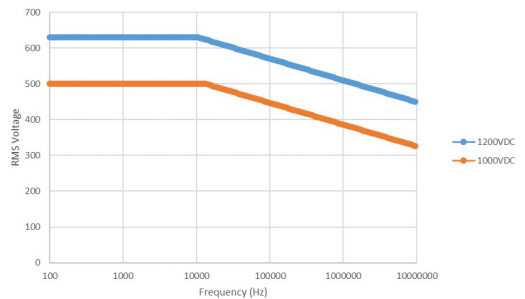

Test data is for 1200 VDC and 1000 VDC ratings only, and unless specified otherwise, all temperature and voltage tests were performed at 1kHz and all frequency tests performed at 25°C.

Capstick® Capacitor
Metallized Polyester Dielectric

CS11

Electrical Characteristics

Capacitance Change (%) Vs. Temperature

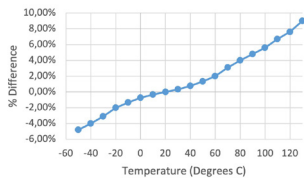

D.F. (%) Vs. AC Volts

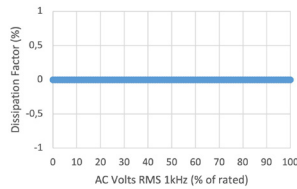

Capacitance Change (%) Vs. DC Bias Voltage

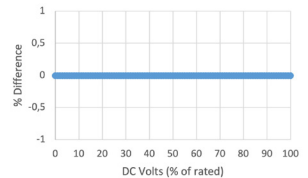

D.F. Vs. Temperature

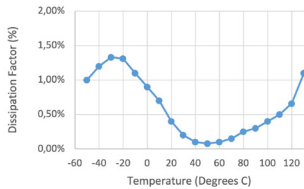

D.F. Vs. Frequency

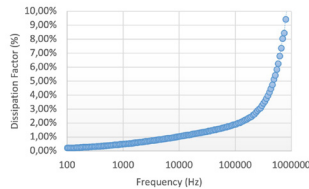

Capacitance (%) Vs. Frequency

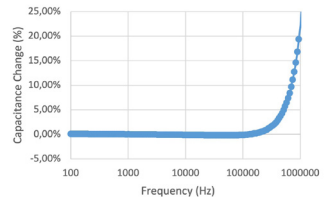

Phase Angle Vs. Frequency

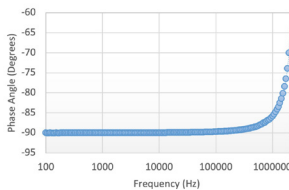

Capacitance Change (%) Vs. Time

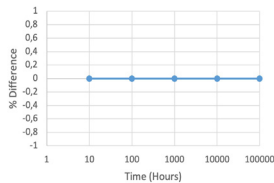

Test data is for 1200 VDC and 1000 VDC ratings only, and unless specified otherwise, all temperature and voltage tests were performed at 1kHz and all frequency tests performed at 25°C.

Evans Trusted Brands. Single Source.
GROUP
Hi-Rel Capacitors for Mission Critical Systems.

Uniting four industry leaders—Evans, Paktron, UTC, and Eulex—Evans Group delivers the industry's most specialized and comprehensive capacitor portfolio.

Together, we provide power-dense, high-reliability solutions engineered for mission-critical environments across defense, aerospace, energy, and advanced RF systems.

Product specifications and technical documentation are provided for informational purposes only, are subject to change without notice, and do not create any warranty except as expressly set forth in the applicable Terms and Conditions of Sale.

Paktron

1205 McConville Road Lynchburg, VA 24504

T +1 434.239.6941

E paktron@evans-group.com

URL www.evans-group.com/paktron