

REVISIONS				
ZONE	REV.	DESCRIPTION	DATE	APPROVED
	A	ORIGINAL RELEASE	12/15/10	

Description:

Part Number 27010722 (Model Number PE2-20-2G18G-5R5-20-12-SFF) is a 2 to 18 GHz low noise amplifier. This amplifier is supplied in our standard PE2 housing that can be used as a SMA connectorized or a surface mount component.

This model provides the following performance. Data is available upon request.

Specifications:

Frequency Range:	2 to 18 GHz
Gain:	20dB Min.
Gain Flatness:	+/- 1.5dB Max.
Noise Figure:	5.5dB Max.
OP1dB:	+19dBm Min.
VSWR Input/Output:	2.0:1 Max.
DC Voltage Supply:	+12 to +15VDC
DC Current Draw:	325mA Typ.
Connectors In/Out	SMA Female

Features:

- Internal Voltage Regulation
- Unconditional Stability
- Standard Operating Temperature -55 to +85 Deg. C

Available Options:

- Various Package types
- Various Connector types
- Temperature Compensation
- Gain and Phase Matching
- MIL-STD-883 Screening Available

Environmental Ratings:

Temperature:	-55 to +85 Deg. C (Operating)
	-65 to +125 Deg. C (Storage)
Humidity:	MIL-STD-202F, METHOD 103B COND B.
Shock:	MIL-STD-202F, METHOD 213B COND B.
Altitude:	MIL-STD-202F, METHOD 105C COND B.
Temperature Cycle:	MIL-STD-202F, METHOD 107D COND A

Note: The above specifications are subject to change or revision.

PE2 HOUSING WITH CARRIER

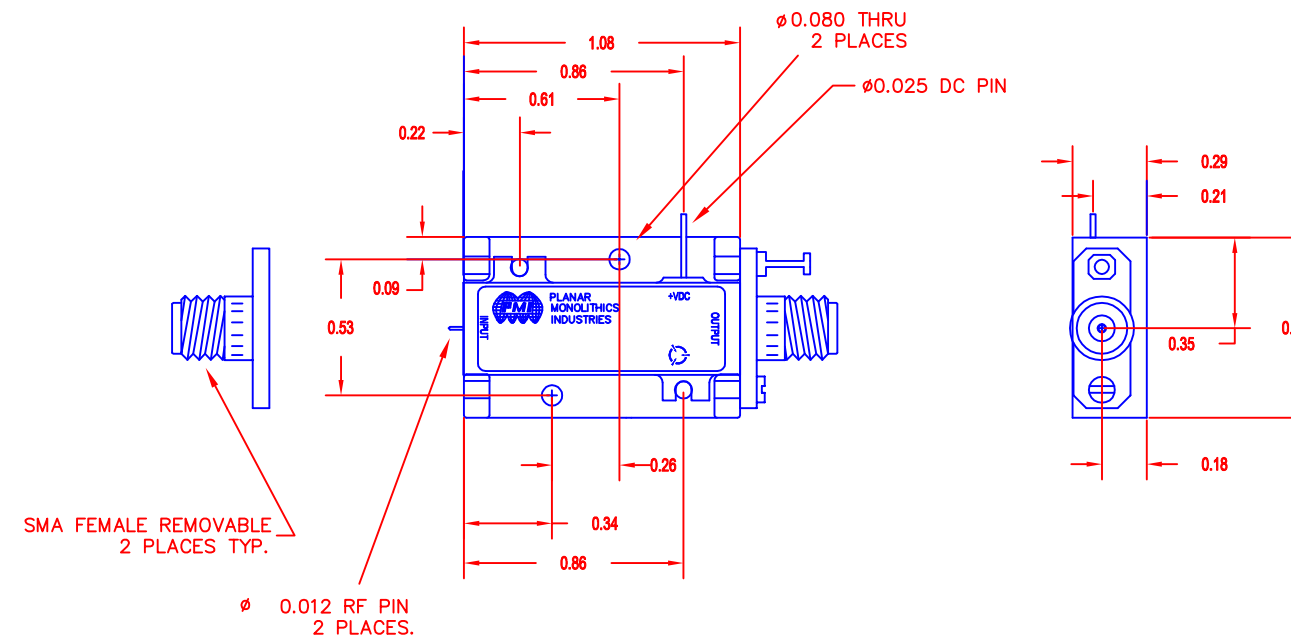

PE2 HOUSING WITHOUT CARRIER (SURFACE MOUNT)

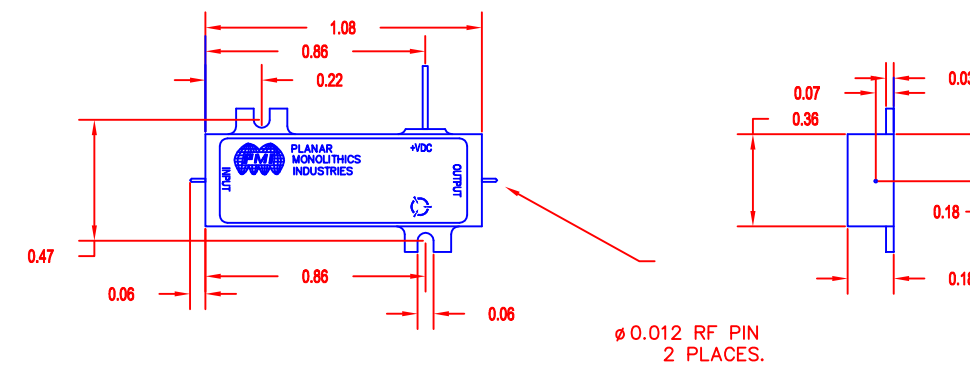

UNLESS OTHERWISE SPECIFIED
DIMENSIONS ARE IN INCHES
TOLERANCES ARE:
FRACTIONS DECIMALS ANGLES
 \pm .XX \pm 0.010 \pm
 \pm .XXX \pm 0.005

MATERIAL: 6061-T6 Aluminum	PART NO.		 7311-F GROVE ROAD FREDERICK, MARYLAND
	APPROVALS	DATE	
FINISH: GOLD PLATED	DRAWN DPD	3/9/10	TITLE PE2 Series Amplifier PE2-20-2G18G-5R5-20-12-SFF
	Modified SFK	12/15/10	
DO NOT SCALE DRAWING	ISSUED		SIZE CAGE CODE DWG NO. REV. B 05XQ0 27010722 A SCALE N/A SHEET 1 OF 1