

REVISIONS				
ZONE	REV.	DESCRIPTION	DATE	APPROVED
-	-	PRELIMINARY	11/15/20	

**Description:**

PMI Model Number PE2-38-218-4R5-17-15-SFF is a 2.0 to 18.0 GHz low noise amplifier. This amplifier is supplied in our standard PE2 housing that can be used as a SMA connectorized or a surface mount component.

This model provides the following performance. Data is available upon request.

**Specifications:**

Frequency Range:	2.0 to 18.0 GHz
Gain:	+38dB Min.
Gain Flatness:	+/- 1.5dB Max.
Noise Figure:	4.5dB Typ.
OP1dB:	+17dBm Min.
VSWR Input/Output:	2.0:1 Max.
DC Voltage Supply:	+15VDC
DC Current Draw:	400mA Max.
Connectors In/Out	SMA Female

**Features:**

- Internal Voltage Regulation
- Unconditional Stability
- Standard Operating Temperature -55 to +85 Deg. C

**Available Options:**

- Various Package types
- Various Connector types
- Temperature Compensation
- Gain and Phase Matching
- MIL-STD-883 Screening Available

**Environmental Ratings:**

Temperature:	-55 to +85 Deg. C (Operating)
	-65 to +125 Deg. C (Storage)
Humidity:	MIL-STD-202F, METHOD 103B COND B.
Shock:	MIL-STD-202F, METHOD 213B COND B.
Altitude:	MIL-STD-202F, METHOD 105C COND B.
Temperature Cycle:	MIL-STD-202F, METHOD 107D COND A

Note: The above specifications are subject to change or revision.

**PE2 HOUSING WITH CARRIER**

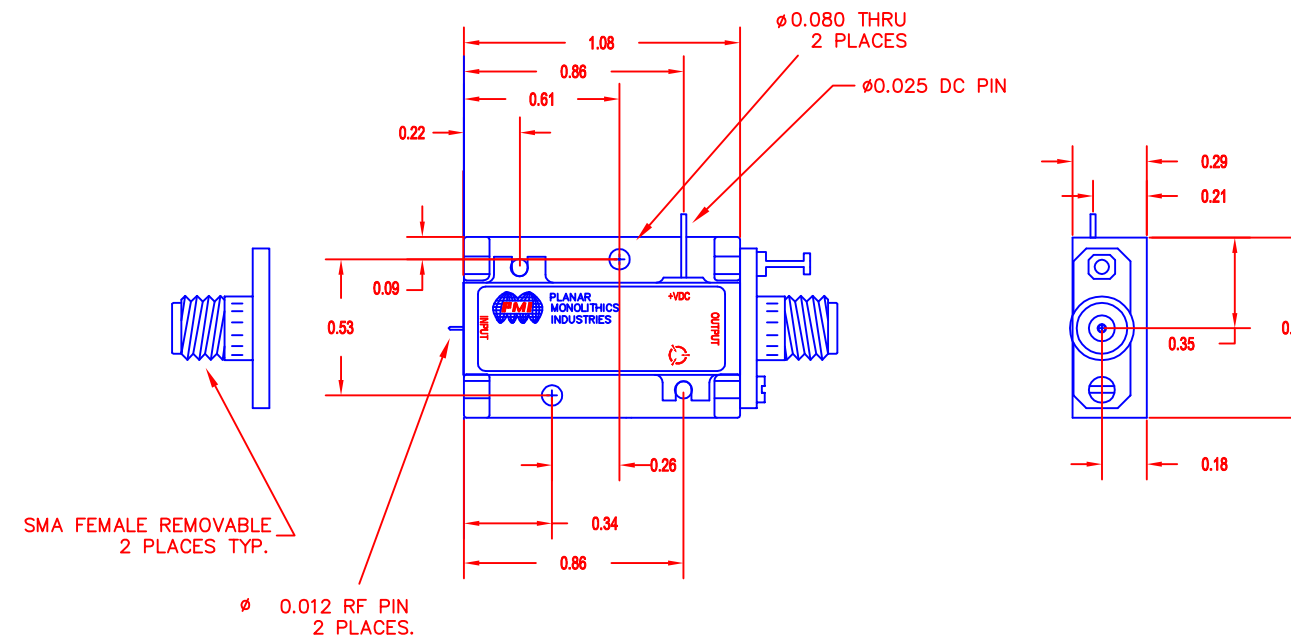

**PE2 HOUSING WITHOUT CARRIER (SURFACE MOUNT)**

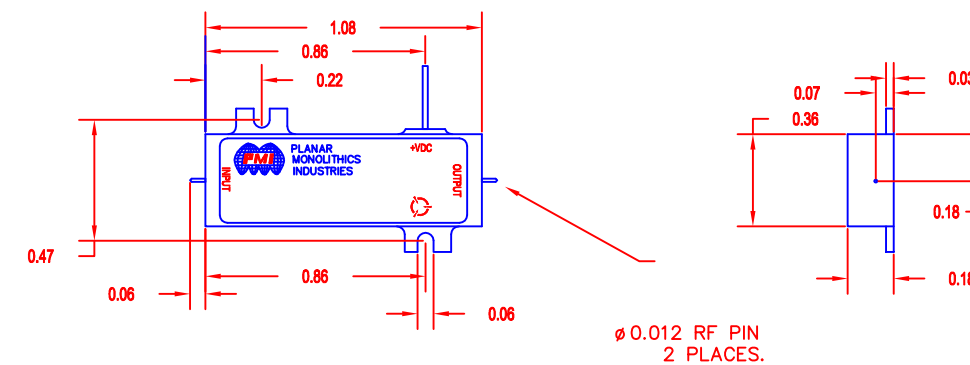

UNLESS OTHERWISE SPECIFIED  
DIMENSIONS ARE IN INCHES  
TOLERANCES ARE:  
FRACTIONS DECIMALS ANGLES  
 $\pm$  .XX  $\pm$  0.010  $\pm$   
 $\pm$  .XXX  $\pm$  0.005

MATERIAL: 6061-T6 Aluminum	PART NO.		 7311-F GROVE ROAD FREDERICK, MARYLAND
	APPROVALS	DATE	
FINISH: GOLD PLATED	DRAWN DPD	3/9/10	TITLE PE2 Series Amplifier PE2-38-218-4R5-17-15-SFF
	Modified CW	11/15/20	SIZE CAGE CODE DWG NO. B 05XQ0 PRELIMINARY
DO NOT SCALE DRAWING	ISSUED		REV. -
	SCALE N/A		SHEET 1 OF 1