

REVISIONS				
ZONE	REV.	DESCRIPTION	DATE	APPROVED
A		ORIGINAL RELEASE	12/13/10	

Description:

Part Number 27003842 (Model Number PE2-40-218-15-SFF) is a 2 to 18 GHz low noise amplifier. This amplifier is supplied in our standard PE2 housing that can be used as a SMA connectorized or a surface mount component.

This model provides the following performance. Data is available upon request.

Specifications:

Frequency Range:	2 to 18 GHz
Gain:	40dB Typ.
Gain Flatness:	+/- 1.75dB Max.
Noise Figure:	4.5dB Max.
OP1dB:	+10dBm Min.
VSWR Input/Output:	2.0:1 Max.
DC Voltage Supply:	+12VDC
DC Current Draw:	300mA Max.
Connectors In/Out	SMA Female

Features:

- Internal Voltage Regulation
- Unconditional Stability
- Standard Operating Temperature -55 to +85 Deg. C

Available Options:

- Various Package types
- Various Connector types
- Temperature Compensation
- Gain and Phase Matching
- MIL-STD-883 Screening Available

Environmental Ratings:

Temperature:	-55 to +85 Deg. C (Operating)
	-65 to +125 Deg. C (Storage)
Humidity:	MIL-STD-202F, METHOD 103B COND B.
Shock:	MIL-STD-202F, METHOD 213B COND B.
Altitude:	MIL-STD-202F, METHOD 105C COND B.
Temperature Cycle:	MIL-STD-202F, METHOD 107D COND A

Note: The above specifications are subject to change or revision.

PE2 HOUSING WITH CARRIER

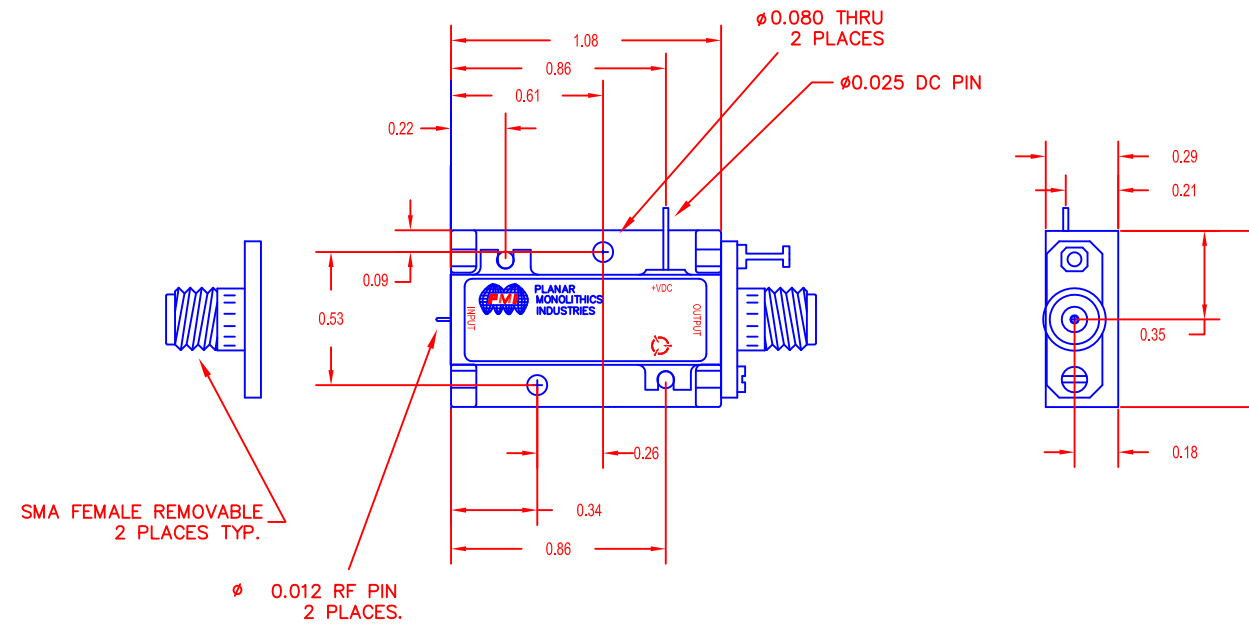

PE2 HOUSING WITHOUT CARRIER (SURFACE MOUNT)

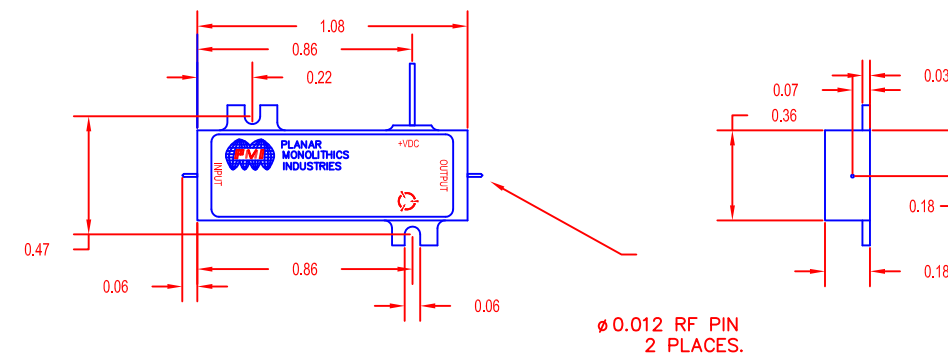

UNLESS OTHERWISE SPECIFIED
DIMENSIONS ARE IN INCHES
TOLERANCES ARE:
FRACTIONS DECIMALS ANGLES
 $\pm .XX \pm 0.010 \pm$
 $.XXX \pm 0.005$

PART NO.		7311-F GROVE ROAD FREDERICK, MARYLAND	
APPROVALS	DATE	TITLE PE2 Series Amplifier PE2-40-218-15-SFF	
DRAWN DPD	3/9/10	SIZE B	CAGE CODE 05XQ0
Mod/Red SFK	12/13/10	DWG NO.	27003842
ISSUED		REV.	A
DO NOT SCALE DRAWING		SCALE N/A	SHEET 1 OF 1