

REVISIONS				
ZONE	REV.	DESCRIPTION	DATE	APPROVED
-	-	PRELIMINARY	6/1/20	

Description:

PMI Model No. PE2-8R012R0-3R0-21-12-SFF is a 8.0 to 12.0 GHz low noise amplifier. This amplifier is supplied in our standard PE2 housing that can be used as a SMA connectorized or a surface mount component.

This model provides the following performance. Data is available upon request.

Specifications:

Frequency Range:	8.0 to 12.0 GHz
Gain:	15dB Typ.
Gain Flatness:	+/- 0.75dB Typ.
Noise Figure:	3.0dB Typ.
OP1dB:	+21dBm Typ.
VSWR Input/Output:	2.0:1 Max.
DC Voltage Supply:	+12 to +15VDC Typ.
DC Current Draw:	225mA Typ.
Connectors In/Out	SMA Female

Features:

- Internal Voltage Regulation
- Unconditional Stability
- Standard Operating Temperature -55 to +85 Deg. C

Available Options:

- Various Package types
- Various Connector types
- Temperature Compensation
- Gain and Phase Matching
- MIL-STD-883 Screening Available

Environmental Ratings:

Temperature:	-55 to +85 Deg. C (Operating)
	-65 to +125 Deg. C (Storage)
Humidity:	MIL-STD-202F, METHOD 103B COND B.
Shock:	MIL-STD-202F, METHOD 213B COND B.
Altitude:	MIL-STD-202F, METHOD 105C COND B.
Temperature Cycle:	MIL-STD-202F, METHOD 107D COND A

Note: The above specifications are subject to change or revision.

PE2 HOUSING WITH CARRIER

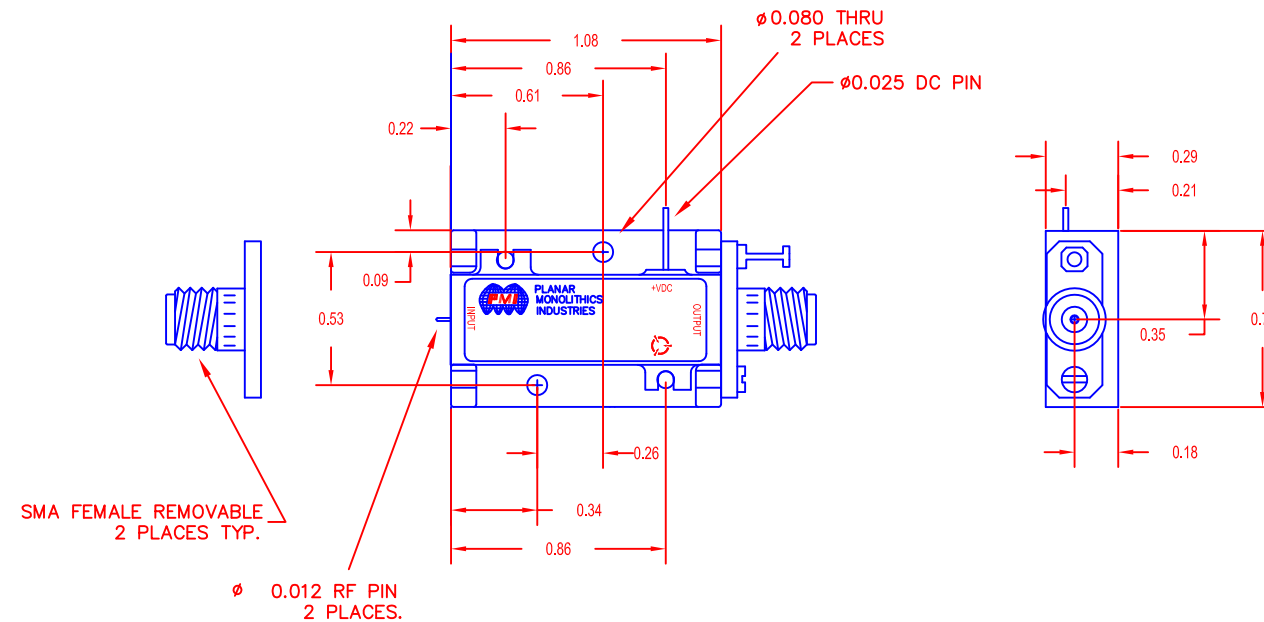

PE2 HOUSING WITHOUT CARRIER (SURFACE MOUNT)

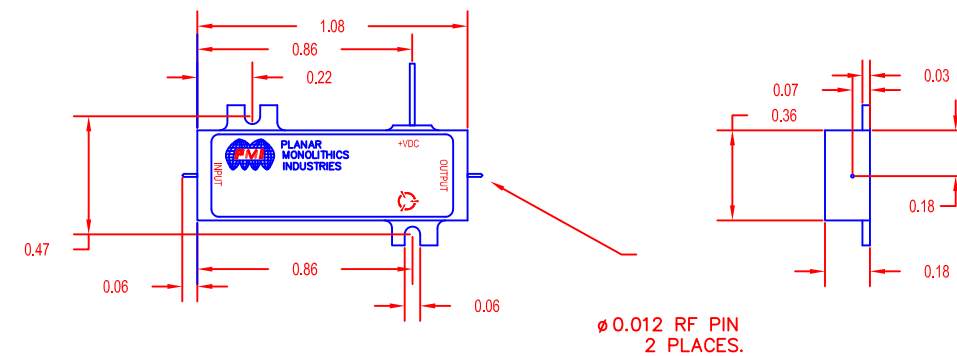

UNLESS OTHERWISE SPECIFIED
DIMENSIONS ARE IN INCHES
TOLERANCES ARE:
FRACTIONS DECIMALS ANGLES
 ± .XX ± 0.010 ±
 .XXX ± 0.005

PART NO.		7311-F GROVE ROAD FREDERICK, MARYLAND	
APPROVALS	DATE	TITLE	
DRAWN DPD	3/9/10	PE2 Series Amplifier	
Modified CW	6/1/20	PE2-8R012R0-3R0-21-12-SFF	
ISSUED		SIZE	CAGE CODE
		B	05XQ0
		DWG NO.	PRELIMINARY
		SCALE	N/A
		SHEET	1 OF 1

DO NOT SCALE DRAWING