

DESCRIPTION:

PMI MODEL NUMBER PEC-20-1840-8-12-292FF IS A LOW NOISE AMPLIFIER DESIGNED FOR MILITARY AND INDUSTRIAL APPLICATIONS. THIS UNIT OFFERS +17 TO +21 dB OF GAIN WITH A GAIN FLATNESS OF 2 dB. THIS MODEL HAS A HOUSING MEASURING 0.39" X 0.44" X 0.11" WITH REMOVEABLE 2.92 mm FEMALE CONNECTORS.

ZONE	REV.	DESCRIPTION	DATE	APPROVED
	1	PRELIMINARY	11/8/2024	

SPECIFICATIONS:

- FREQUENCY RANGE:..... 18 TO 40 GHz
- GAIN:..... +17 TO +21 dB TYP
- GAIN FLATNESS:..... ±2 dB TYP
- NOISE FIGURE:..... 3.7 dB TYP
- OIP3:..... +16 dBm TYP
- OP1dB:..... +8 dBm TYP
- VSWR (INPUT/OUTPUT):..... 2.3:1 TYP
- DC VOLTAGE SUPPLY:..... +12 TO +15 VDC
- DC CURRENT DRAW:..... 100 mA TYP
- CONNECTORS:..... 2.92 mm FEMALE
- FINISH:..... GOLD PLATED

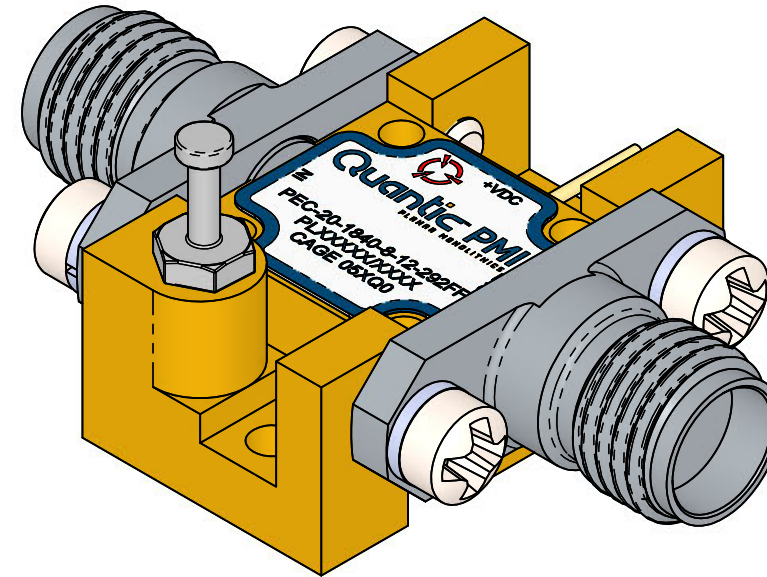

ENVIRONMENTAL RATINGS:

- TEMPERATURE:..... -55°C TO +85°C (OPERATING)
-65°C TO +125°C (STORAGE)
- HUMIDITY:..... 95% RELATIVE HUMIDITY, NONCONDENSING
- VIBRATION:..... 7 g's RMS, 50-5000 CPS, PER MIL-STD-810B, METHOD 514, PROCEDURE

PMI CONFIDENTIAL AND PROPRIETARY

NOTE: SPECIFICATIONS WILL VARY OVER TEMPERATURE
NOTE: THE ABOVE SPECIFICATIONS ARE SUBJECT TO CHANGE OR REVISION

UNLESS OTHERWISE SPECIFIED DIMENSIONS ARE IN INCHES TOLERANCES ARE: FRACTIONS DECIMALS ANGLES ± .XX ± 0.02 ± .XXX ± 0.01		APPROVALS	DATE	Quantic PMI PLANAR MONOLITHICS 7309-A GROVE ROAD FREDERICK MARYLAND 21704 USA TEL: (301) 662-5019, FAX: (301) 662-1731 WEB: WWW.QUANTICPMI.COM, EMAIL: SALES@QUANTICPMI.COM ISO 9001 CERTIFIED			
		DRAWN J ESCANO REDRAWN	11/8/2024				TITLE OUTLINE PEC-20-1840-8-12-292FF
		ISSUED		SIZE	FSCM NO.	DWG NO.	REV.
				B	05XQ0	PRELIMINARY	1
		SCALE 4:1			SHEET 1 OF 2		

HOUSING WITH CARRIER

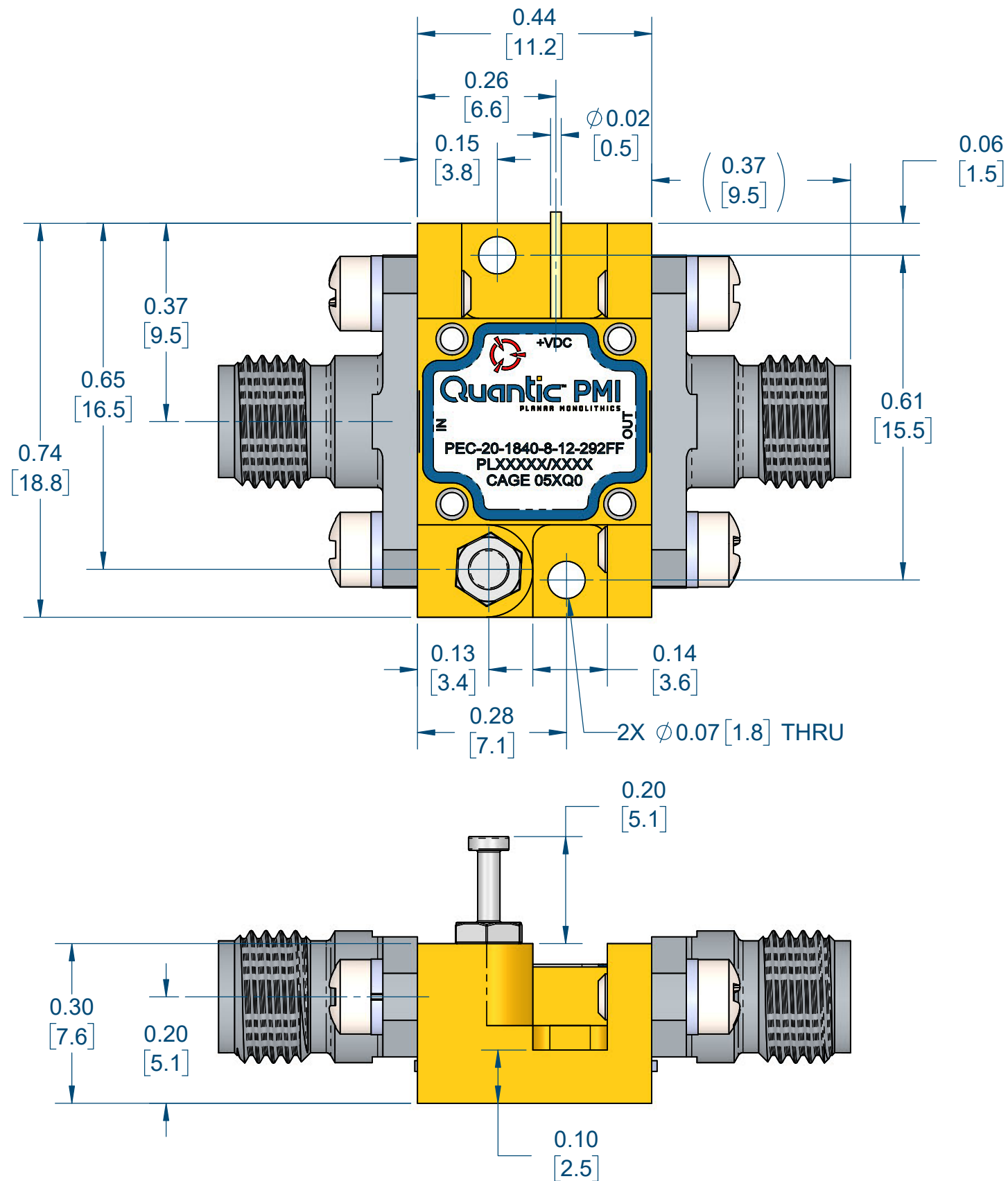

HOUSING WITHOUT CARRIER (SURFACE MOUNT)

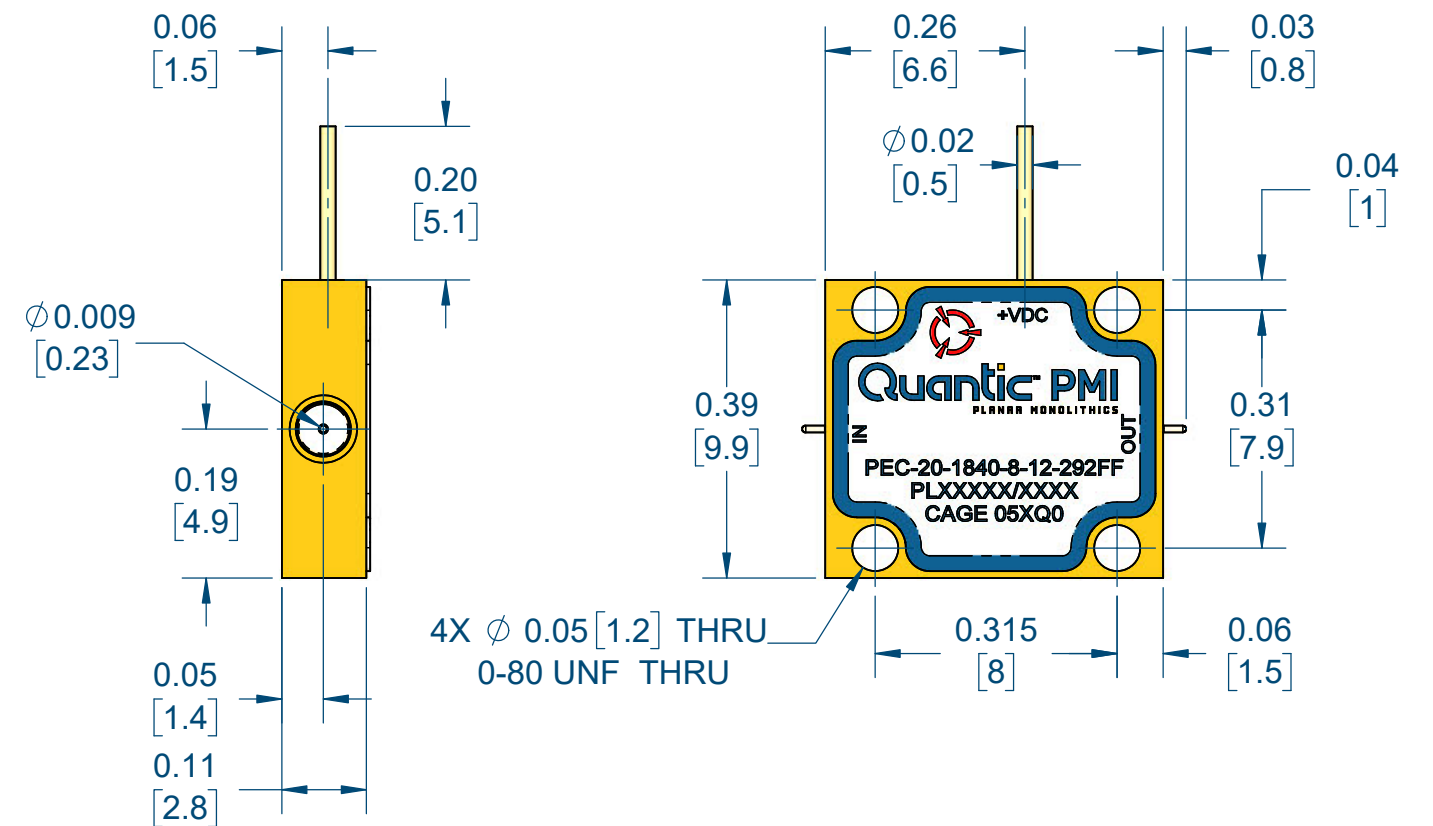

NOTE: SPECIFICATIONS WILL VARY OVER TEMPERATURE
NOTE: THE ABOVE SPECIFICATIONS ARE SUBJECT TO CHANGE OR REVISION

PMI CONFIDENTIAL AND PROPRIETARY

APPROVALS DRAWN REDRAWN ISSUED		DATE		TITLE OUTLINE PEC-20-1840-8-12-292FF			
		11/8/2024		SIZE	FSCM NO.	DWG NO.	REV.
UNLESS OTHERWISE SPECIFIED DIMENSIONS ARE IN INCHES TOLERANCES ARE: FRACTIONS .XX ± 0.02 DECIMALS .XXX ± 0.01 ANGLES ±		B	05XQ0	PRELIMINARY	1	SCALE 4:1	
				SHEET 2 OF 2			

Quantic PMI
PLANNED MONOLITHICS

7309-A GROVE ROAD FREDERICK MARYLAND 21704 USA
TEL: (301) 662-5019, FAX: (301) 662-1731
WEB: WWW.QUANTICPMI.COM, EMAIL: SALES@QUANTICPMI.COM
ISO 9001 CERTIFIED