

ZONE	REV.	DESCRIPTION	DATE	APPROVED
	1	PRELIMINARY	11/27/2024	

DESCRIPTION:

PMI MODEL PSM-2X4X2-SP4T-300M3G-3UVPX IS A RECEIVE AND TRANSMIT SWITCH MATRIX WITH 2 RECEIVE INPUTS AND 4 RECEIVE OUTPUTS AS WELL AS 2 TRANSMIT OUTPUTS WITH 4 TRANSMIT INPUTS. THERE IS ALSO A SINGLE POLE FOUR THROW SWITCH INCLUDED FOR THE RECEIVE PATH ON A THIRD RECEIVE INPUT. THE UNIT COVERS 300 MHz TO 3 GHz IN A 3U VPX FORM

SPECIFICATIONS:

- FREQUENCY RANGE:..... 0.03 TO 3 GHz
- INSERTION LOSS:..... 3.5 dB MAX
- VSWR (ON/OFF):..... 2.0:1 MAX
- CHANNEL ISOLATION:..... 60 dB MIN
- OPERATING INPUT POWER:..... +20 dBm MAX
- SURVIVAL INPUT POWER:..... +30 dBm MAX
- SWITCHING SPEED:..... 1 us MAX
- POWER SUPPLY :..... +12 VDC / +3.3 VDC AVAILABLE ON P0 CONNECTOR
- CONTROL:..... TTL LOGIC ON P1 CONNECTOR
- CONNECTORS:..... VITA 67.3C RF CONNECTOR
P0 POWER, P1 CONTROL CONNECTORS

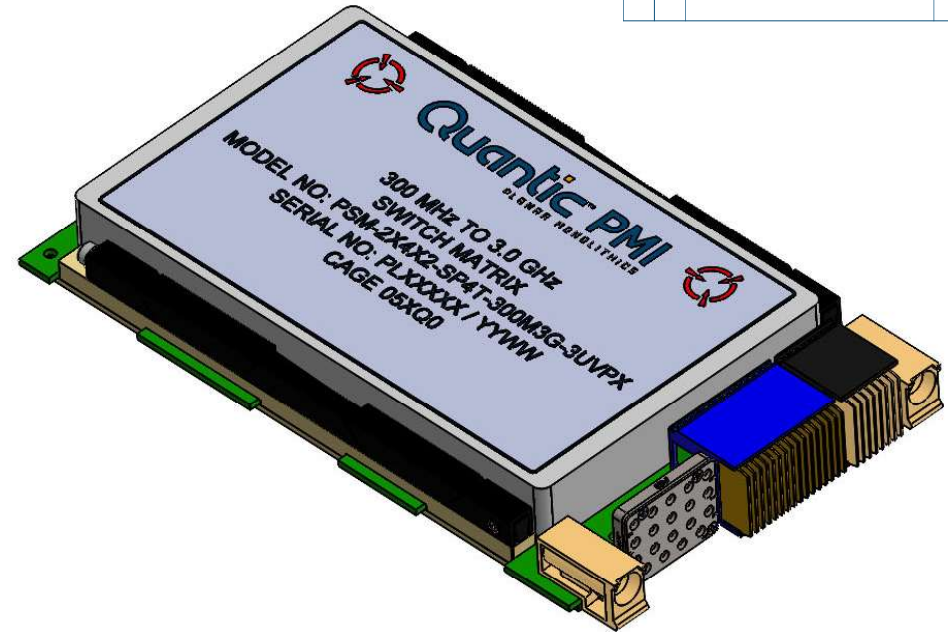

VITA 67.3 CONNECTOR	
1 - TX ANTENNA A	11 - PAY2 RX2
2 - TX ANTENNA B	12 - PAY3 RX2
3 - RX ANTENNA A	13 - PAY4 RX2
4 - RX ANTENNA B	14 - PAY1 TX1
5 - RX ANTENNA C	15 - PAY2 TX1
6 - PAY1 RX1	16 - PAY3 TX1
7 - PAY2 RX1	17 - PAY4 TX1
8 - PAY3 RX1	18 - NO CONNECT (NC)
9 - PAY4 RX1	19 - NO CONNECT (NC)
10 - PAY1 RX2	

P0 PIN#	NAME	P0 PIN#	NAME	P0 PIN#	NAME	P0 PIN#	NAME	P0 PIN#	NAME	P0 PIN#	NAME	P0 PIN#	NAME
a1	Vs2 (+3.3V)	b1	Vs2 (+3.3V)	c1	Vs2 (+3.3V)	d1	NC	e1	Vs1 (+12V)	f1	Vs1 (+12V)	g1	Vs1 (+12V)
a2	Vs2 (+3.3V)	b2	Vs2 (+3.3V)	c2	Vs2 (+3.3V)	d2	NC	e2	Vs1 (+12V)	f2	Vs1 (+12V)	g2	Vs1 (+12V)
a3	Vs3 (+5V)	b3	Vs3 (+5V)	c3	Vs3 (+5V)	d3	NC	e3	Vs3 (+5V)	f3	Vs3 (+5V)	g3	Vs3 (+5V)
a4	NC	b4	NC	c4	GND	d4	-12V	e4	GND	f4	NC	g4	NC
a5	NC	b5	NC	c5	GND	d5	+3.3V AUX	e5	GND	f5	NC	g5	NC
a6	NC	b6	NC	c6	GND	d6	+12V AUX	e6	GND	f6	NC	g6	NC
a7	NC	b7	NC	c7	GND	d7	NC	e7	NC	f7	GND	g7	GND
a8	GND	b8	NC	c8	NC	d8	GND	e8	NC	f8	NC	g8	NC

*P1 CONNECTOR PINOUT TBD

ENVIRONMENTAL RATINGS:

- TEMPERATURE:..... -40°C TO +85°C (OPERATING)
-55°C TO +125°C (STORAGE)

NOTE: SPECIFICATIONS WILL VARY OVER TEMPERATURE
NOTE: THE ABOVE SPECIFICATIONS ARE SUBJECT TO CHANGE OR REVISION

PMI CONFIDENTIAL AND PROPRIETARY

APPROVALS		DATE	TITLE			
DRAWN	D. DURBIN	11/27/2024	SWITCH MATRIX			
REDRAWN			PSM-2X4X2-SP4T-300M3G-3UVPX			
ISSUED			SIZE	FSCM NO.	DWG NO.	REV.
			B	05XQ0	PRELIMINARY	1
			SCALE 1:1	SHEET 1 OF 2		

UNLESS OTHERWISE SPECIFIED
DIMENSIONS ARE IN INCHES
TOLERANCES ARE:
FRACTIONS DECIMALS ANGLES
± .005 ± 0.02 ±

Quantic PMI
FLORHAM HIGHLANDS
7309-A GROVE ROAD FREDERICK MARYLAND 21704 USA
TEL: (301) 862-5019 FAX: (301) 862-1731
WEB: WWW.QUANTICPMI.COM EMAIL: SALES@QUANTICPMI.COM
ISO 9001 CERTIFIED

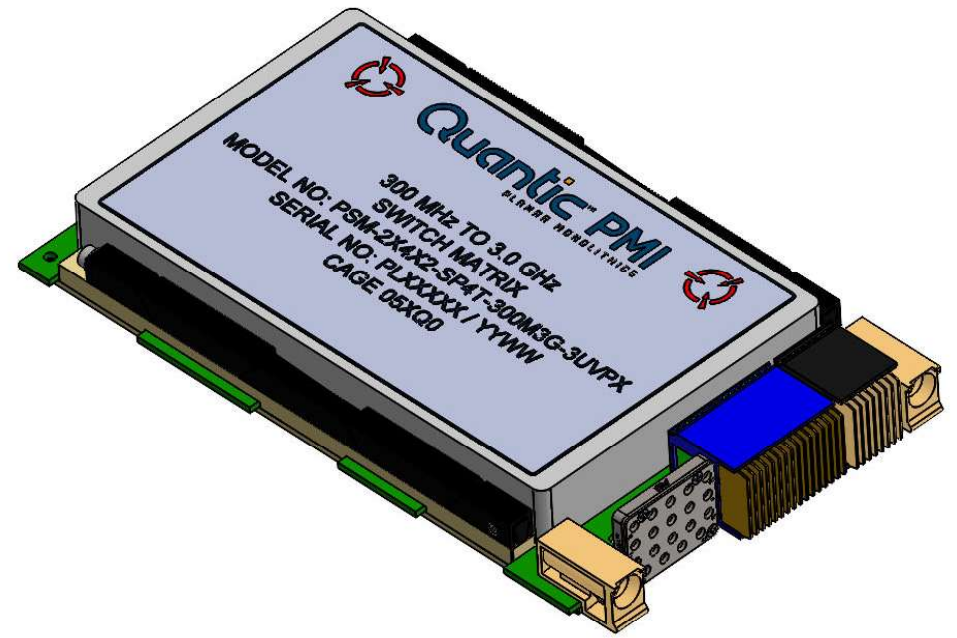
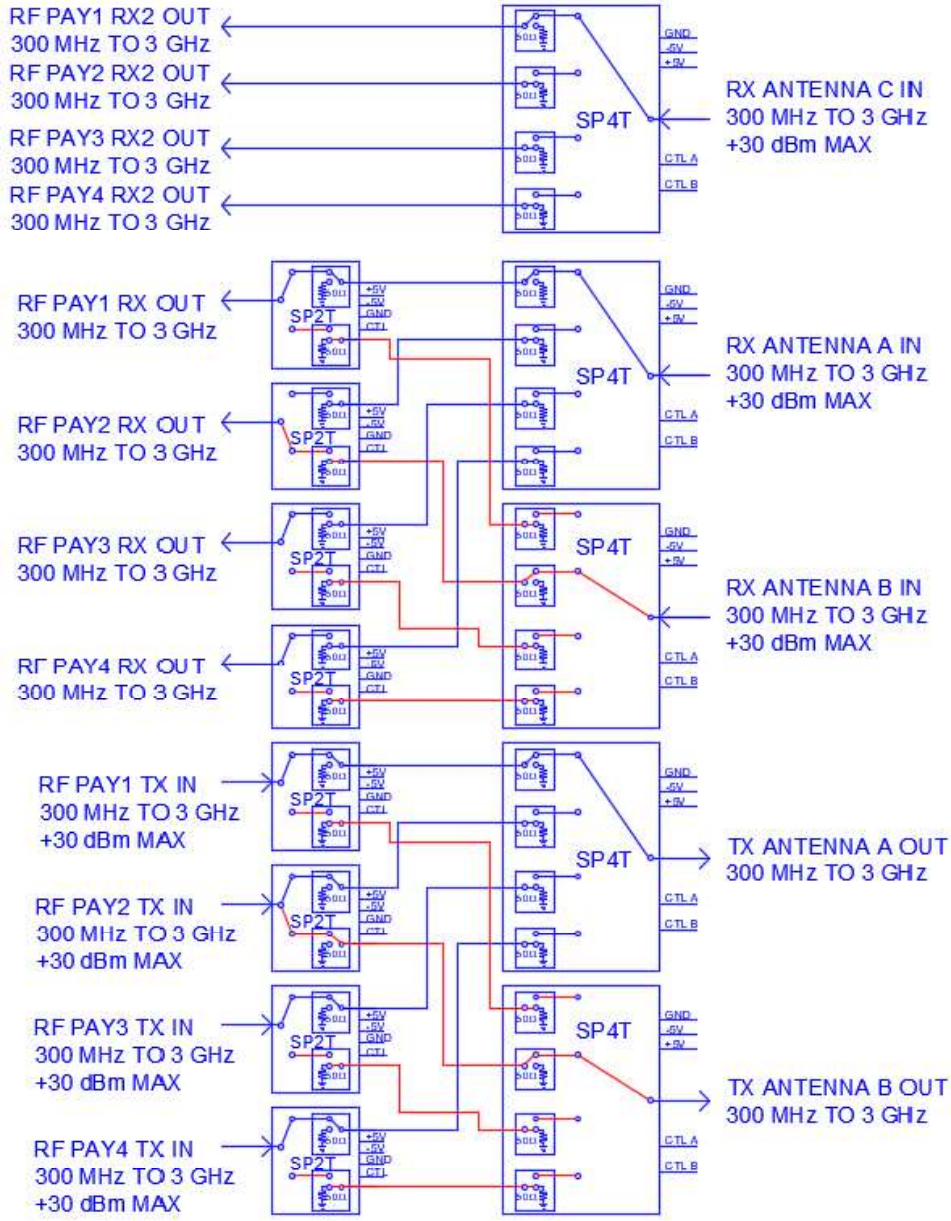

PMI CONFIDENTIAL AND PROPRIETARY

UNLESS OTHERWISE SPECIFIED DIMENSIONS ARE IN INCHES TOLERANCES ARE:		APPROVALS D. DURBIN		DATE 11/27/2024	Quantic PMI <small>PLUMMER MOBILITIES</small> 7309-A GROVE ROAD FREDERICK MARYLAND 21704 USA TEL: (301) 862-5019 FAX: (301) 862-1751 WEB: WWW.QUANTICPMI.COM EMAIL: SALES@QUANTICPMI.COM ISO 9001 CERTIFIED		
		REDRAWN		TITLE SWITCH MATRIX	PSM-2X4X2-SP4T-300M3G-3UVPX		
ISSUED		SIZE B	FSCM NO. 05XQ0	DWG NO. PRELIMINARY	REV. 1	SCALE 1:1 SHEET 2 OF 2	