

REVISIONS				
ZONE	REV.	DESCRIPTION	DATE	APPROVED
	A	ORIGINAL RELEASE	12/13/10	

Description:

Part Number 27003562 (Model Number PE2-28-1113-7R0-25-12-SFF) is a 10.7 to 12.75 GHz low noise amplifier. This amplifier is supplied in our standard PE2 housing that can be used as a SMA connectorized or a surface mount component.

This model provides the following performance. Data is available upon request.

Specifications:

Frequency Range:	10.7 to 12.75 GHz
Gain:	30dB Typ.
Gain Flatness:	+/- 1.0dB Max.
Noise Figure:	7.0dB Max.
OP1dB:	+24dBm Min.
VSWR Input/Output:	2.0:1 Max.
DC Voltage Supply:	+12 to +15VDC
DC Current Draw:	400mA Max.
Connectors In/Out	SMA Female

Features:

- Internal Voltage Regulation
- Unconditional Stability
- Standard Operating Temperature -55 to +85 Deg. C

Available Options:

- Various Package types
- Various Connector types
- Temperature Compensation
- Gain and Phase Matching
- MIL-STD-883 Screening Available

Environmental Ratings:

Temperature:	-55 to +85 Deg. C (Operating)
	-65 to +125 Deg. C (Storage)
Humidity:	MIL-STD-202F, METHOD 103B COND B.
Shock:	MIL-STD-202F, METHOD 213B COND B.
Altitude:	MIL-STD-202F, METHOD 105C COND B.
Temperature Cycle:	MIL-STD-202F, METHOD 107D COND A

Note: The above specifications are subject to change or revision.

PE2 HOUSING WITH CARRIER

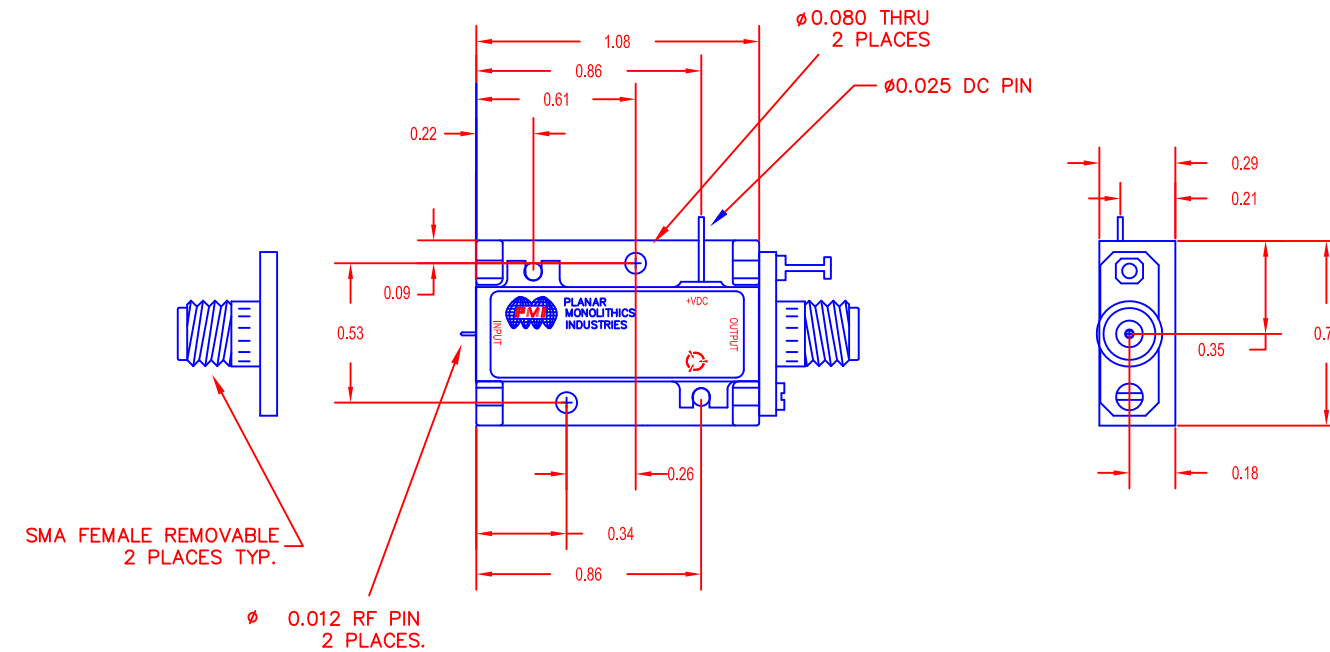

PE2 HOUSING WITHOUT CARRIER (SURFACE MOUNT)

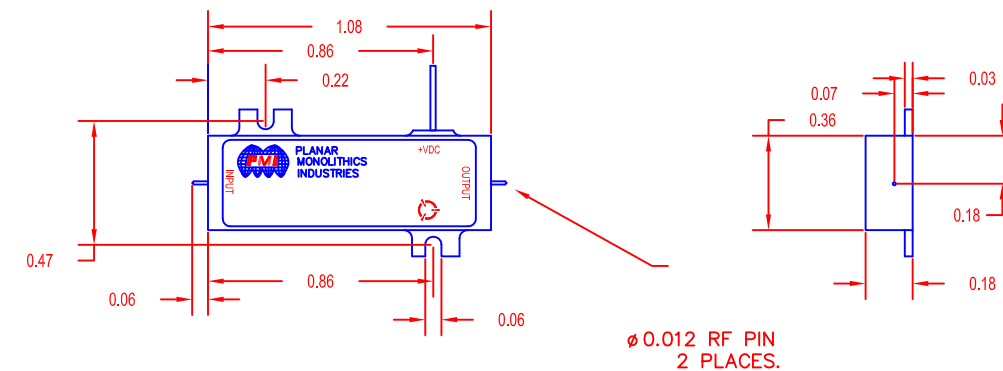

UNLESS OTHERWISE SPECIFIED
DIMENSIONS ARE IN INCHES
TOLERANCES ARE:
FRACTIONS DECIMALS ANGLES
± .XX ± 0.010 ±
.XXX ± 0.005

MATERIAL: 6061-T6 Aluminum	APPROVALS	DATE	 7311-F GROVE ROAD FREDERICK, MARYLAND	TITLE PE2 Series Amplifier PE2-28-1113-7R0-25-12-SFF
	ISSUED			
FINISH: GOLD PLATED	DRAWN DPD	3/9/10	SIZE B	CAGE CODE 05XQ0
DO NOT SCALE DRAWING	Modified SFK	12/13/10	DWG NO. 27003562	REV. A
			SCALE N/A	SHEET 1 OF 1