

## DESCRIPTION

PMI MODEL PSD-2G6G-CD-1 IS A INTEGRATED AMPLIFIER SWITCH BOX ASSEMBLY WITH THE FOLLWING SPECIFICATIONS

## SPECIFICATIONS

- FINAL ASSEMBLY:
  - FREQUENCY RESPONSE: . . . . . 2.0 – 6.0 GHz
  - POWER: . . . . . 110VAC ONLY, 50/60Hz
  - SIZE: . . . . . (L) 15.0" X (W) 10.0" X (H) 4.0"
  - FINISH: . . . . . PAINTED GRAY
  - WEIGHT: . . . . . 20 POUNDS(LBS) TYP
- PIN DIODE SWITCH:
  - POWER HANDLING: . . . . .  $\geq 10$  W
  - FREQUENCY RESPONSE: . . . . . 2.0 – 6.0 GHz
  - SWITCHING SPEED: . . . . .  $< 50$  ns
- THRESHOLD DETECTOR:
  - FREQUENCY RESPONSE: . . . . . 2.0 – 6.0 GHz
  - SWITCHING SPEED: . . . . .  $< 50$  ns
  - OUTPUT TYPE: . . . . . TTL (Compatible With Pin Switch)
  - SENSITIVITY: . . . . .  $< -40$ dBm
  - MAX POWER (NO DAMAGE): . . . . . 10 dBm
- COUPLER:
  - POWER HANDLING: . . . . .  $\geq 10$  W
  - FREQUENCY RESPONSE: . . . . . 2.0 – 6.0 GHz
  - COUPLING FACTOR: . . . . . 20 dB
- 50 Ohm LOAD:
  - POWER HANDLING: . . . . .  $\geq 10$  W
  - FREQUENCY RESPONSE: . . . . . 2.0 – 6.0 GHz
- ATTENUATOR:
  - POWER HANDLING: . . . . .  $> 2$  W
  - FREQUENCY RESPONSE: . . . . . 2.0 – 6.0 GHz
  - ATTENUATION: . . . . . 0 – 69 By (1) Front Panel Knob or Thumb Wheel

## ENVIRONMENTAL RATINGS

- TEMPERATURE: . . . . . -35°C TO +85°C (OPERATING)
- . . . . . -40°C TO +85°C (STORAGE)
- HUMIDITY: . . . . . MIL-STD-202F, METHOD 103B COND. B
- SHOCK: . . . . . MIL-STD-202F, METHOD 213B COND. B
- VIBRATION: . . . . . MIL-STD-202F, METHOD 204D COND. B
- ALTITUDE: . . . . . MIL-STD-202F, METHOD 105C COND. B
- TEMPERATURE CYCLE: . . . . . MIL-STD-202F, METHOD 107D COND. A

NOTE: SPECIFICATIONS WILL VARY OVER OPERATING TEMPERATURE  
NOTE: THE ABOVE SPECIFICATIONS ARE SUBJECT TO CHANGE DR REVISION

ALL DIMENSIONS ARE IN INCHES  
TOLERANCES:  
X.XX ±0.5

PMI CONFIDENTIAL AND PROPRIETARY

REVISIONS				
ZONE	REV.	DESCRIPTION	DATE	APPROVED
	A1	ORIGINAL RELEASE	03/12/13	

## MECHANICAL OUTLINE

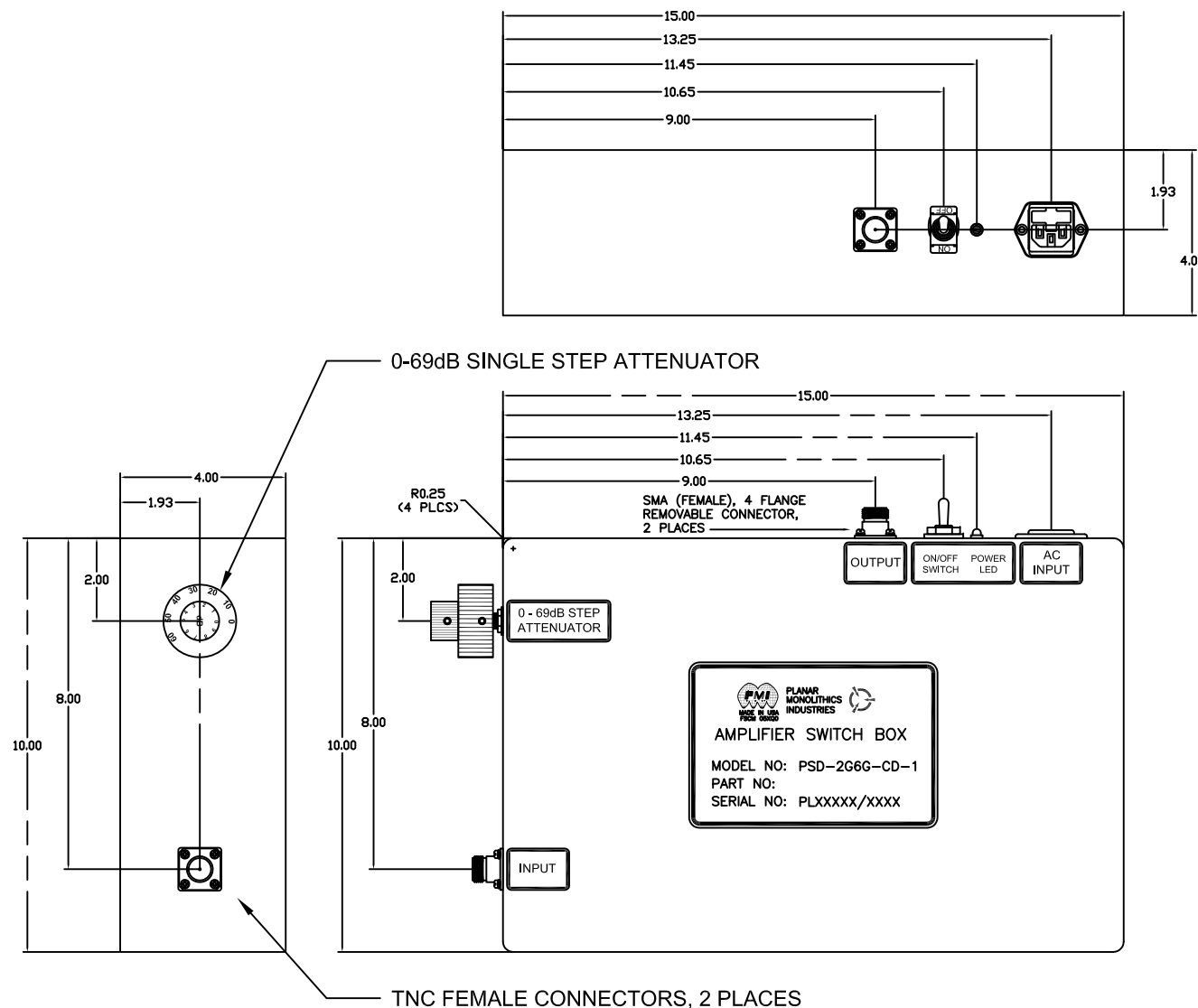

**PLANAR MONOLITHICS INDUSTRIES, INC.**  
7311-F GROVE ROAD  
FREDERICK, MARYLAND 21704 USA  
TEL: 301-662-5019 FAX: 301-662-1731  
WEBSITE: [www.pmi-rf.com](http://www.pmi-rf.com)  
E-MAIL: [sales@pmi-rf.com](mailto:sales@pmi-rf.com)  
ISO 9001:2000 CERTIFIED



APPROVALS		DATE	TITLE			
DRAWN <i>ANG</i>		03/12/13	PRODUCT FEATURE PSD-2G6G-CD-1			
CHECKED			SIZE A	FSCM NO. 05XQ0	DWG NO. 27017721	REV. A1
ISSUED			SCALE N:S		SHEET 1 OF 2	

# DESCRIPTION

PMI MODEL PSD-2G6G-CD-1 IS A INTEGRATED AMPLIFIER SWITCH BOX ASSEMBLY WITH THE FOLLWING SPECIFICATIONS

REVISIONS				
ZONE	REV.	DESCRIPTION	DATE	APPROVED
	A1	ORIGINAL RELEASE	03/12/13	

## BLOCK DIAGRAM

VARIABLE LIMIT HIGH POWER, HIGH SPEED, LONG LIFETIME DYNAMIC RANGE LIMITER

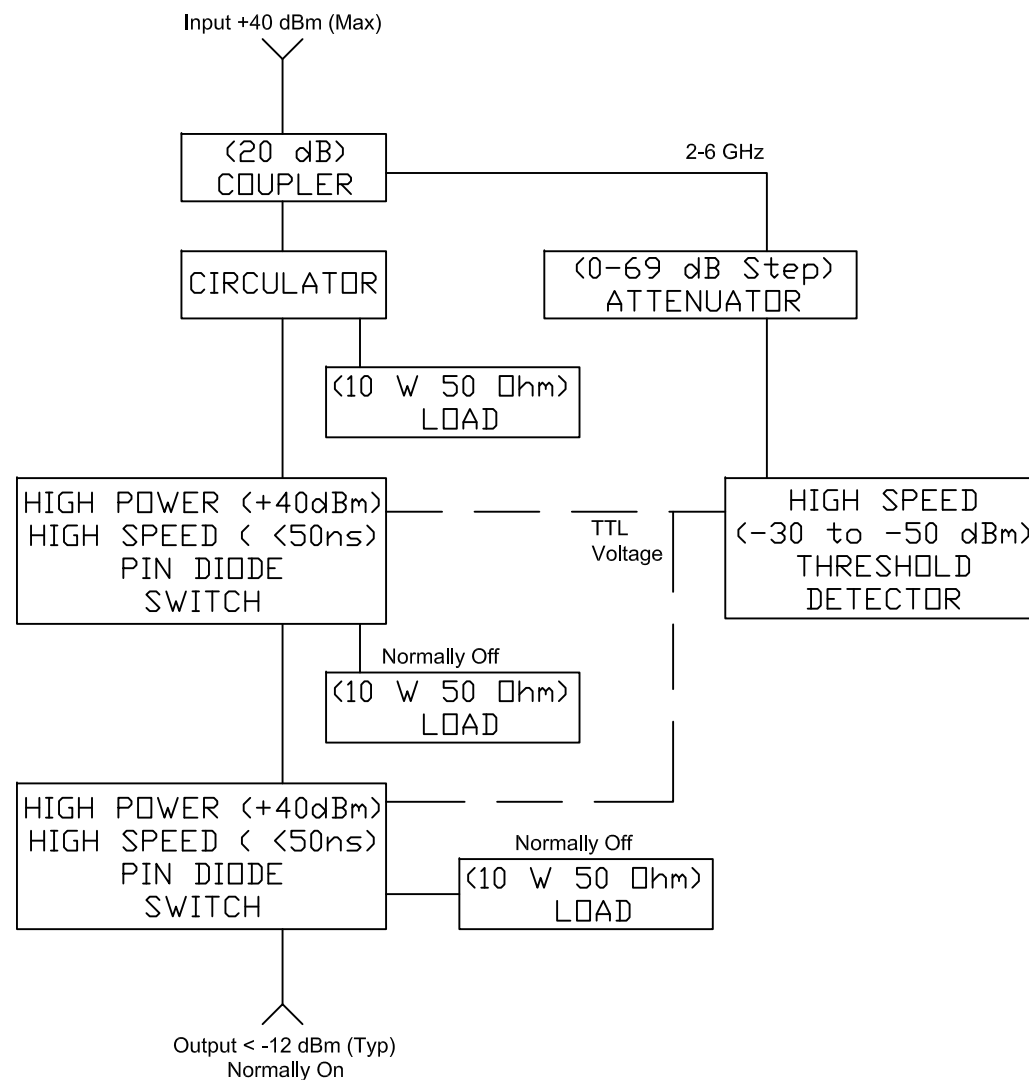

### ENVIRONMENTAL RATINGS

- **TEMPERATURE:** -35°C TO +85°C (OPERATING)  
-40°C TO +85°C (STORAGE)
- **HUMIDITY:** MIL-STD-202F, METHOD 103B COND. B
- **SHOCK:** MIL-STD-202F, METHOD 213B COND. B
- **VIBRATION:** MIL-STD-202F, METHOD 204D COND. B
- **ALTITUDE:** MIL-STD-202F, METHOD 105C COND. B
- **TEMPERATURE CYCLE:** MIL-STD-202F, METHOD 107D COND. A

NOTE: SPECIFICATIONS WILL VARY OVER OPERATING TEMPERATURE  
NOTE: THE ABOVE SPECIFICATIONS ARE SUBJECT TO CHANGE OR REVISION

ALL DIMENSIONS ARE IN INCHES  
TOLERANCES:  
X.XX ±0.5

PMI CONFIDENTIAL AND PROPRIETARY

**PLANAR MONOLITHICS INDUSTRIES, INC.**  
7311-F GROVE ROAD  
FREDERICK, MARYLAND 21704 USA  
TEL: 301-662-5019 FAX: 301-662-1731  
WEBSITE: [www.pmi-rf.com](http://www.pmi-rf.com)  
E-MAIL: [sales@pmi-rf.com](mailto:sales@pmi-rf.com)  
ISO 9001:2000 CERTIFIED



APPROVALS		DATE	TITLE			
DRAWN <i>ANG</i>		03/12/13	BLOCK DIAGRAM PSD-2G6G-CD-1			
CHECKED			SIZE	FSCM NO.	DWG NO.	REV.
			A	05XQ0	27017721	A1
ISSUED			SCALE	N:S	SHEET	2 OF 2