

DESCRIPTION

PMI MODEL NO. P4T-1G1R1R-45-T-SFF-4KW IS A SOLID-STATE, ABSORPTIVE SP4T SWITCH THAT IS DESIGNED FOR USE IN IFF APPLICATIONS. THIS SWITCH OPERATES FROM 1.0 GHz TO 1.1 GHz AND HANDLES PEAK INPUT POWER LEVELS UP TO 4.0 kW PEAK HAVING A MAXIMUM PULSE WIDTH OF 32 us AND A DUTY CYCLE OF 1%.

SPECIFICATIONS:

- FREQUENCY RANGE: 1020 MHz to 1100 MHz
- RF INPUT POWER: 4.0 kW PEAK
- PULSE WIDTH: 0.8 us to 32 us
- DUTY CYCLE: 1% MAXIMUM
- INSERTION LOSS: 1.0 dB MAXIMUM
- ISOLATION: 45 dB MINIMUM
- SWITCHING RATE: 2 kHz MAXIMUM
- SWITCHING SPEED: 30 us MAXIMUM (50% TTL TO 10% & 90% RF)
- SWITCH CONTROLS: TTL LOGIC - INDIVIDUAL CONTROL
 "0" = ISOLATION
 "1" = INSERTION LOSS
- DC SUPPLIES: +50 V, 50 mA NOMINAL
 +5 V, 400 mA NOMINAL
- RF CONNECTORS: SMA FEMALE
- SIZE: 6.0" DIAMETER RADIAL x 0.50" THICK
- SEALING: HERMETIC SEALED RF / EPOXY SEALED DRIVER
- FINISH: EPOXY PAINTED BLUE (MOUNTING SURFACE FREE OF PAINT)
- NOTES:
 1. COLD SWITCHING ONLY OR DAMAGE WILL OCCUR. (DO NOT HOT SWITCH)
 2. ONE PATH TO BE IN INSERTION LOSS MODE AT ALL TIMES WHEN HIGH POWER IS PRESENT.
 3. INPUT POWER RATING APPLIES TO J1 PORT.
 4. SOURCE & LOAD TERMINATIONS TO BE BETTER THAN 1.5:1

ENVIRONMENTAL RATINGS

- TEMPERATURE: -45° C TO +85° C (OPERATING - BASE PLATE)
 -54° C TO +125° C (NON-OPERATING)
- ENVIRONMENTAL: MIL-STD-810E
- EMI/EMC: MIL-STD-461

NOTE: SPECIFICATIONS WILL VARY OVER OPERATING TEMPERATURE

REVISIONS				
ZONE	REV.	DESCRIPTION	DATE	APPROVED
	—	PRELIMINARY	6/17/15	KM

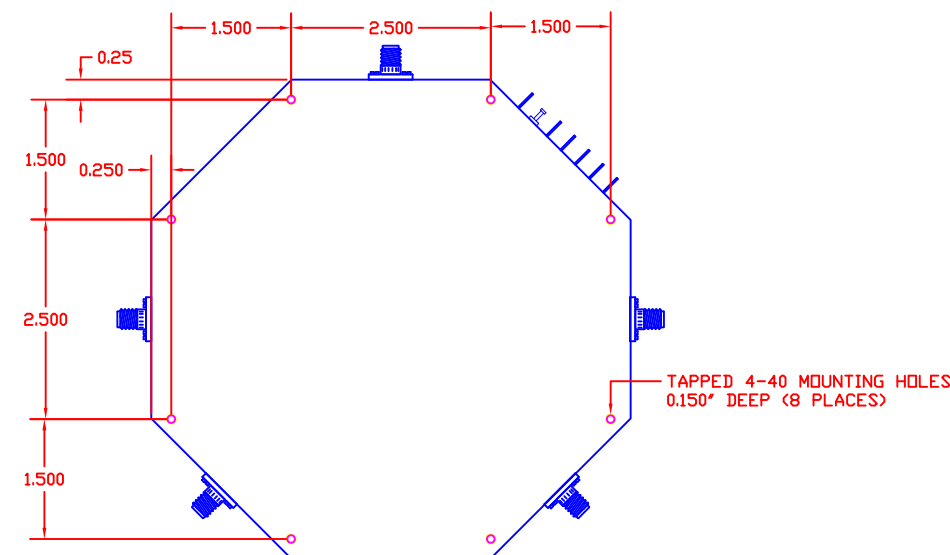
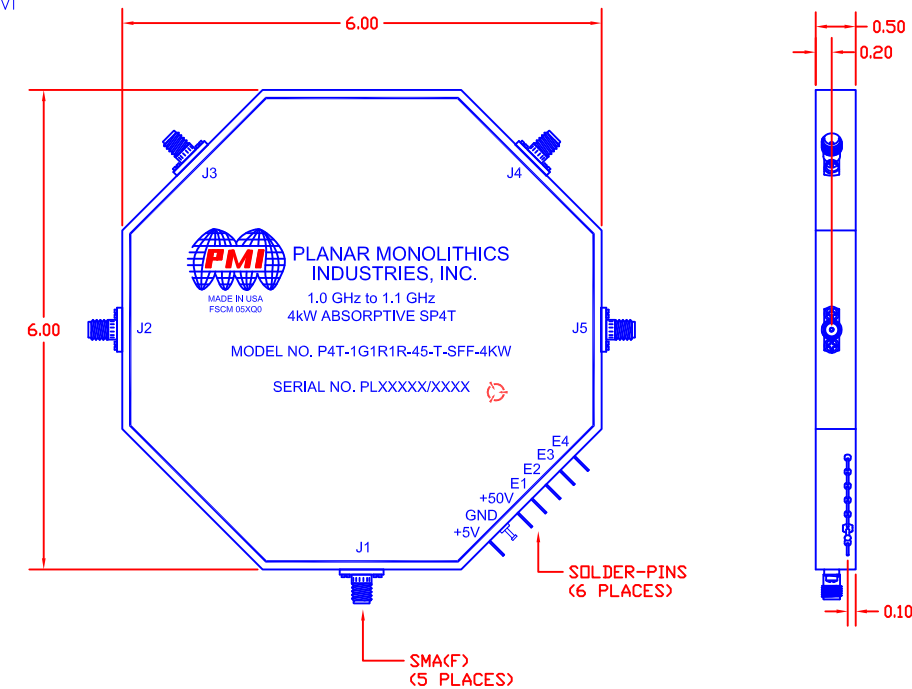

PMI CONFIDENTIAL AND PROPRIETARY

PLANAR MONOLITHICS INDUSTRIES, INC.

7311-F GROVE ROAD
 FREDERICK, MARYLAND 21704 USA
 TEL: 301-662-5019 FAX: 301-662-1731
 WEBSITE: www.pmi-rf.com
 E-MAIL: sales@pmi-rf.com
 ISO 9001 CERTIFIED



APPROVALS		DATE	TITLE			
DRAWN <i>K. MASON</i>		6/17/15	PRODUCT FEATURE			
CHECKED			P4T-1G1R1R-45-T-SFF-4KW			
ISSUED			SIZE	FSCM NO.	DWG NO.	REV.
			A	05XQ0	PRELIMINARY	—
			SCALE	N: S	SHEET	1 OF 3