

DESCRIPTION

THE MODEL P8T-500M18G-60-T-515-SFF-2W IS A HIGH SPEED, SINGLE POLE, EIGHT THROW, ABSORPTIVE SWITCH CAPABLE OF SWITCHING WITHIN 200 ns. THE FREQUENCY RANGE IS 0.5 TO 18.0 GHz AND THIS SWITCH HAS OVER 60dB OF ISOLATION.

SPECIFICATIONS

- FREQUENCY RANGE: 0.5 TO 18.0 GHz
- ISOLATION 60 dB MIN
- INSERTION LOSS 6.5 dB TYP, 8 dB MAX
- VSWR IN/OUT 2.0:1 MAX
- OPERATING INPUT POWER +33 dBm CW MAX
- SWITCHING SPEED 200 ns MAX
- DC VOLTAGE AND CURRENT +5 VDC
-15 VDC
- CONTROL SIGNAL 3 LINE DECODED TTL
See Table 1
- CONNECTORS SMA (F)
- FINISH BLUE EPOXY POLIMIDE

ENVIRONMENTAL RATINGS

- TEMPERATURE: -54 °C TO +95 °C (OPERATING)
-65 °C TO +125 °C (STORAGE)
- HUMIDITY: MIL-STD-202F, METHOD 103B COND. B
- SHOCK: MIL-STD-202F, METHOD 213B COND. B
- VIBRATION: MIL-STD-202F, METHOD 204D COND. B
- ALTITUDE: MIL-STD-202F, METHOD 105C COND. B
- TEMPERATURE CYCLE: MIL-STD-202F, METHOD 107D COND. A

NOTE: SPECIFICATIONS WILL VARY OVER OPERATING TEMPERATURE
NOTE: THE ABOVE SPECIFICATIONS ARE SUBJECT TO CHANGE OR REVISION

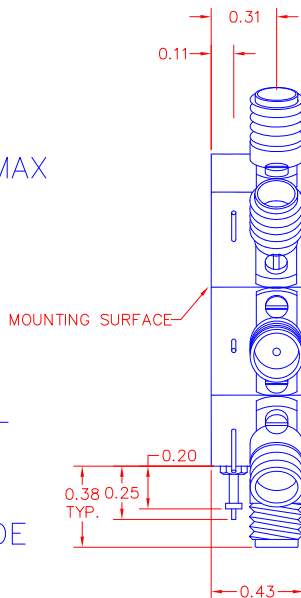

REVISIONS				
ZONE	REV.	DESCRIPTION	DATE	APPROVED
	-	PRELIMINARY	11/11/15	

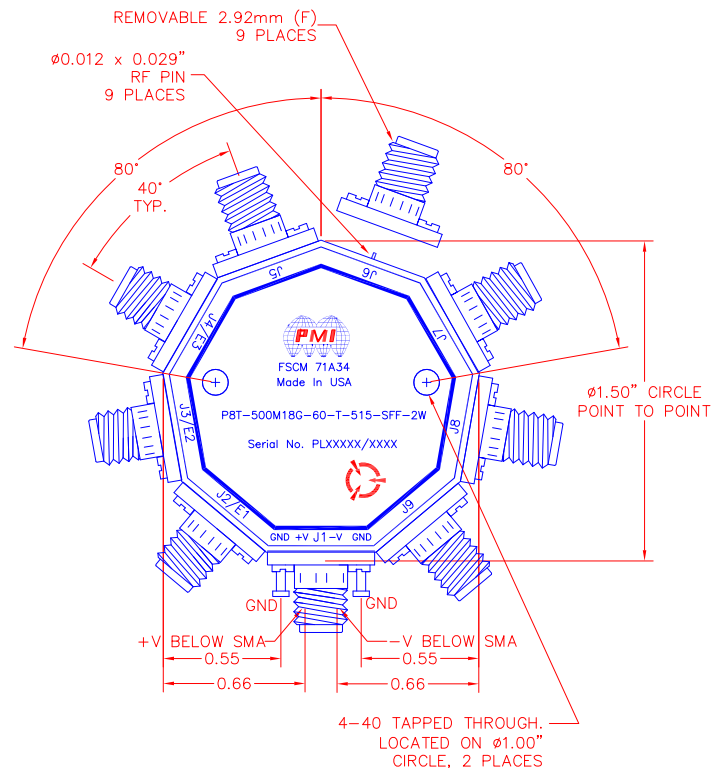

Table 1

E1	E2	E3	FUNCTION
0	0	0	J1-J2
0	0	1	J1-J3
0	1	0	J1-J4
0	1	1	J1-J5
1	0	0	J1-J6
1	0	1	J1-J7
1	1	0	J1-J8
1	1	1	J1-J9

ALL DIMENSIONS ARE IN INCHES
TOLERANCES:
X.XX ±0.020
X.XXX ±0.010

PMI CONFIDENTIAL AND PROPRIETARY

PLANAR MONOLITHICS INDUSTRIES, INC.

4921 ROBERT J MATHEWS PKWY, STE 1
EL DORADO HILLS, CALIFORNIA 95762
TEL: 916-542-1401 FAX: 916-265-2597
WEBSITE: www.pmi-rf.com
E-MAIL: sales@pmi-rf.com
ISO 9001 CERTIFIED



APPROVALS		DATE	TITLE			
DRAWN <i>JS</i>		11/11/15	PRODUCT FEATURE			
CHECKED			P8T-500M18G-60-T-515-SFF-2W			
ISSUED			0.5 TO 18.0 GHz HIGH SPEED SWITCH 8 THROW			
SIZE	FSCM NO.	DWG NO.	REV.			
A	71A34	PRELIMINARY	-			
SCALE N:S			SHEET 1 OF 1			