

DESCRIPTION:

PMI MODEL NUMBER PSM-50M20G-8X8-ENET-3U-SFF IS A 16 PORT SWITCH MATRIX WITH 8 INPUT PORTS AND 8 OUTPUT PORTS COVERING 50 MHZ TO 20 GHz. ETHERNET CONTROL SETS THE PORT CONNECTIONS.

REVISIONS				
ZONE	REV.	DESCRIPTION	DATE	APPROVED
	1	PRELIMINARY	3/15/21	

SPECIFICATIONS:

- FREQUENCY RANGE: 50 MHz TO 20 GHz
- NUMBER OF PORTS: 16 (8 INPUTS, 8 OUTPUTS)
- INSERTION LOSS: 3 dB TYP, 4 dB MAX
- PORT TO PORT ISOLATION: 80 dB TYP, 60 dB MIN
- RF INPUT POWER: 1 W MAXIMUM
- SWITCH CONTROL: ETHERNET CONTROL
- CONNECTORS: SMA (F)
- POWER SUPPLY: 110VAC, 60 Hz
FUSE PROTECTION INCLUDED
- SIZE: 3U 19" RACKMOUNT CHASSIS
- FINISH: POWDER COATED BLUE

ENVIRONMENTAL RATINGS:

- OPERATING TEMPERATURE: 10° TO 40° C

CONCEPTUAL BLOCK DIAGRAM:

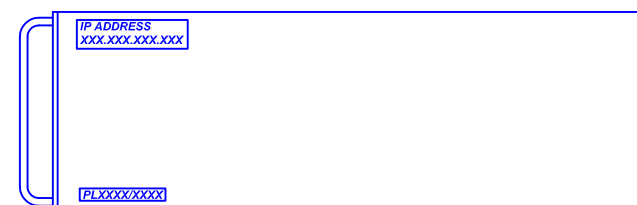
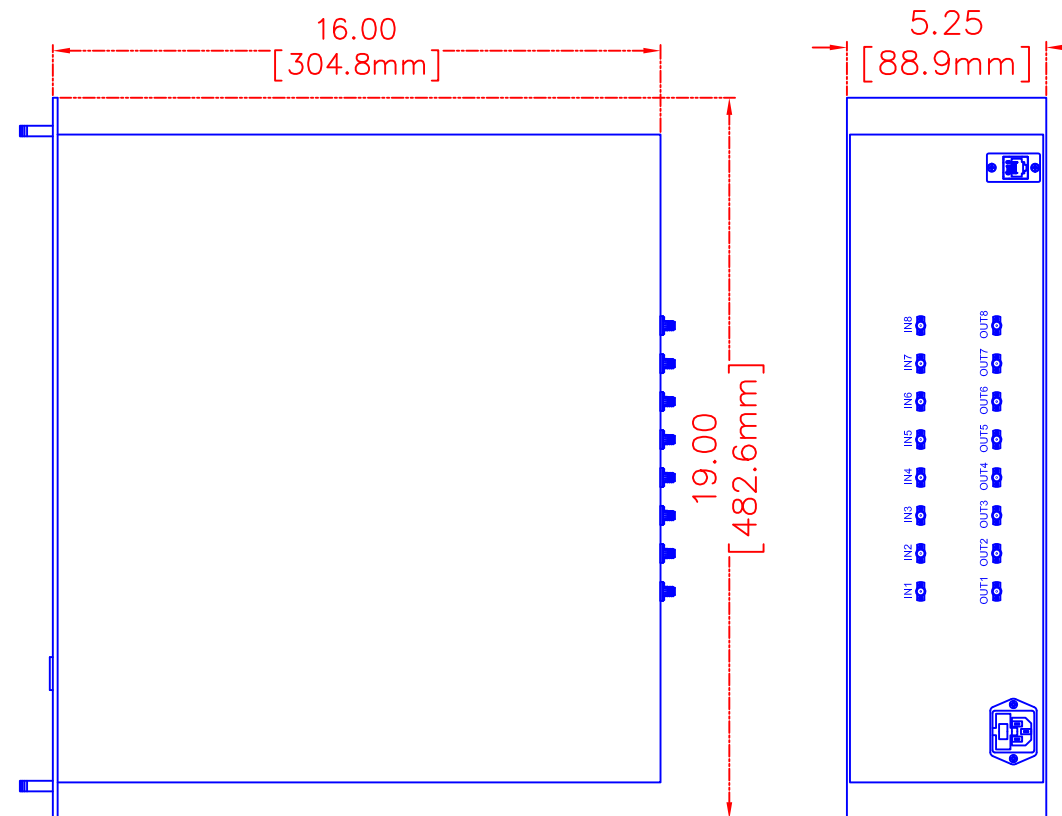
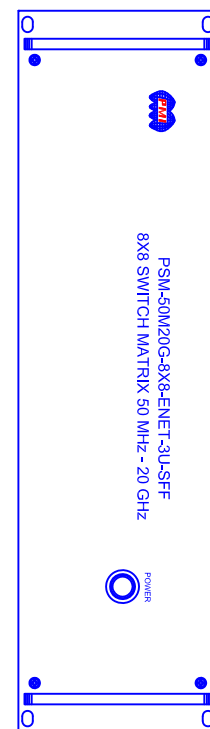
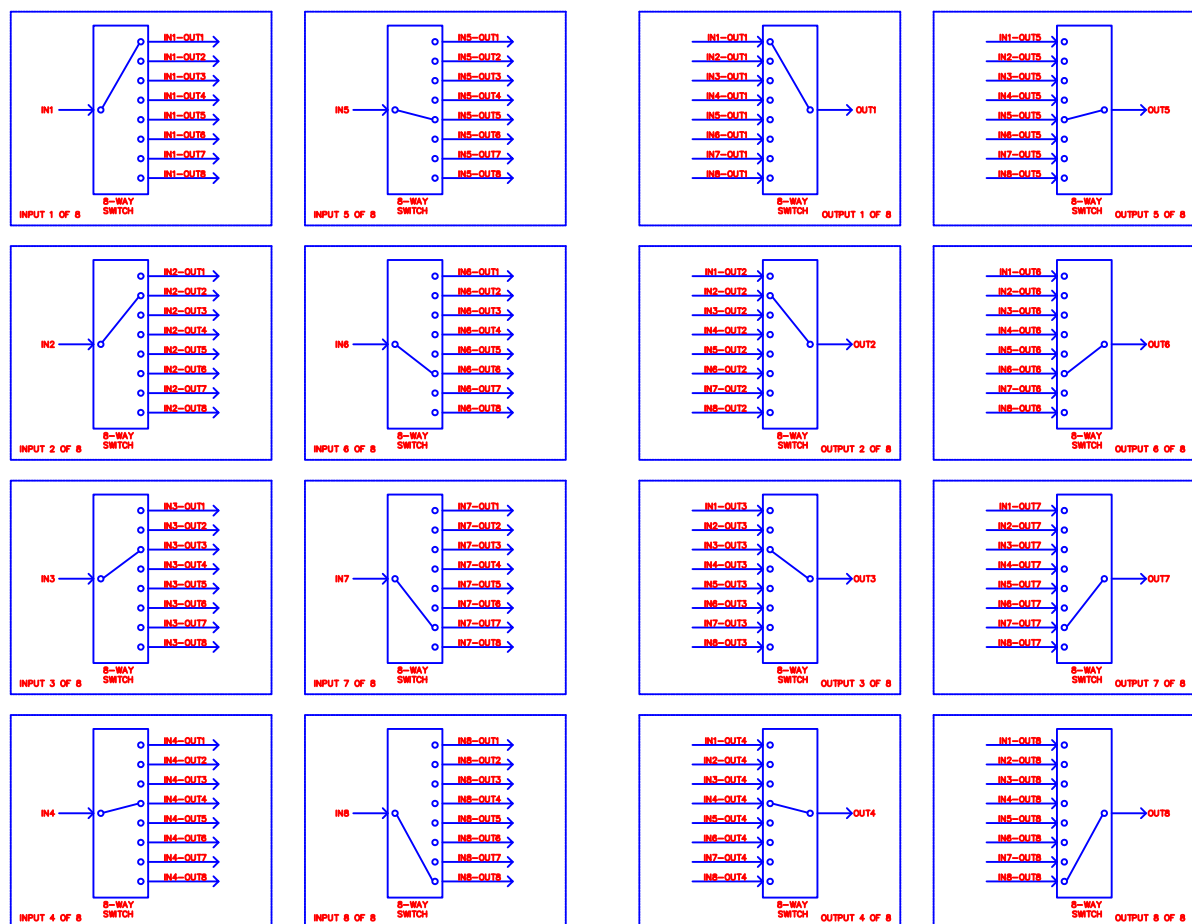

PMI CONFIDENTIAL AND PROPRIETARY

PLANAR MONOLITHICS INDUSTRIES, INC.

7311-F GROVE ROAD
 FREDERICK, MARYLAND 21704 USA
 TEL: 301-662-5019 FAX: 301-662-1731
 WEBSITE: www.pmi-rf.com
 E-MAIL: sales@pmi-rf.com
 ISO 9001 CERTIFIED



APPROVALS		DATE	TITLE		
DRAWN	DPD	3/9/21	PRODUCT FEATURE PSM-50M20G-8X8-ENET-3U-SFF		
CHECKED			SIZE	FSCM NO.	DWG NO.
ISSUED			B	05XQ0	PRELIMINARY
			SCALE	N:S	SHEET 1 OF 3

ALL DIMENSIONS ARE IN INCHES
 TOLERANCES:
 X.XX ±0.020
 X.XXX ±0.010

NOTE: THE ABOVE SPECIFICATIONS ARE SUBJECT TO CHANGE OR REVISION

MECHANICAL OUTLINE:

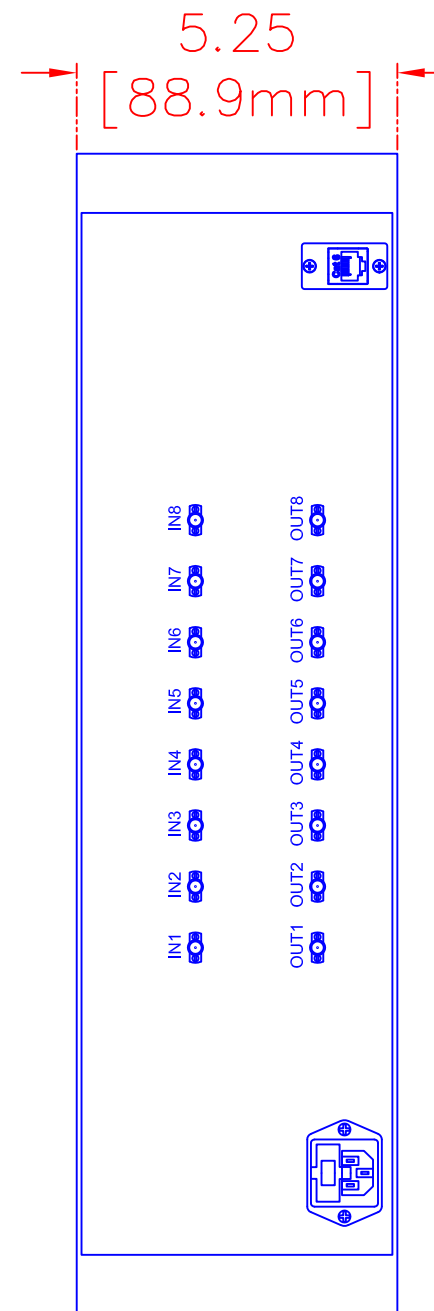
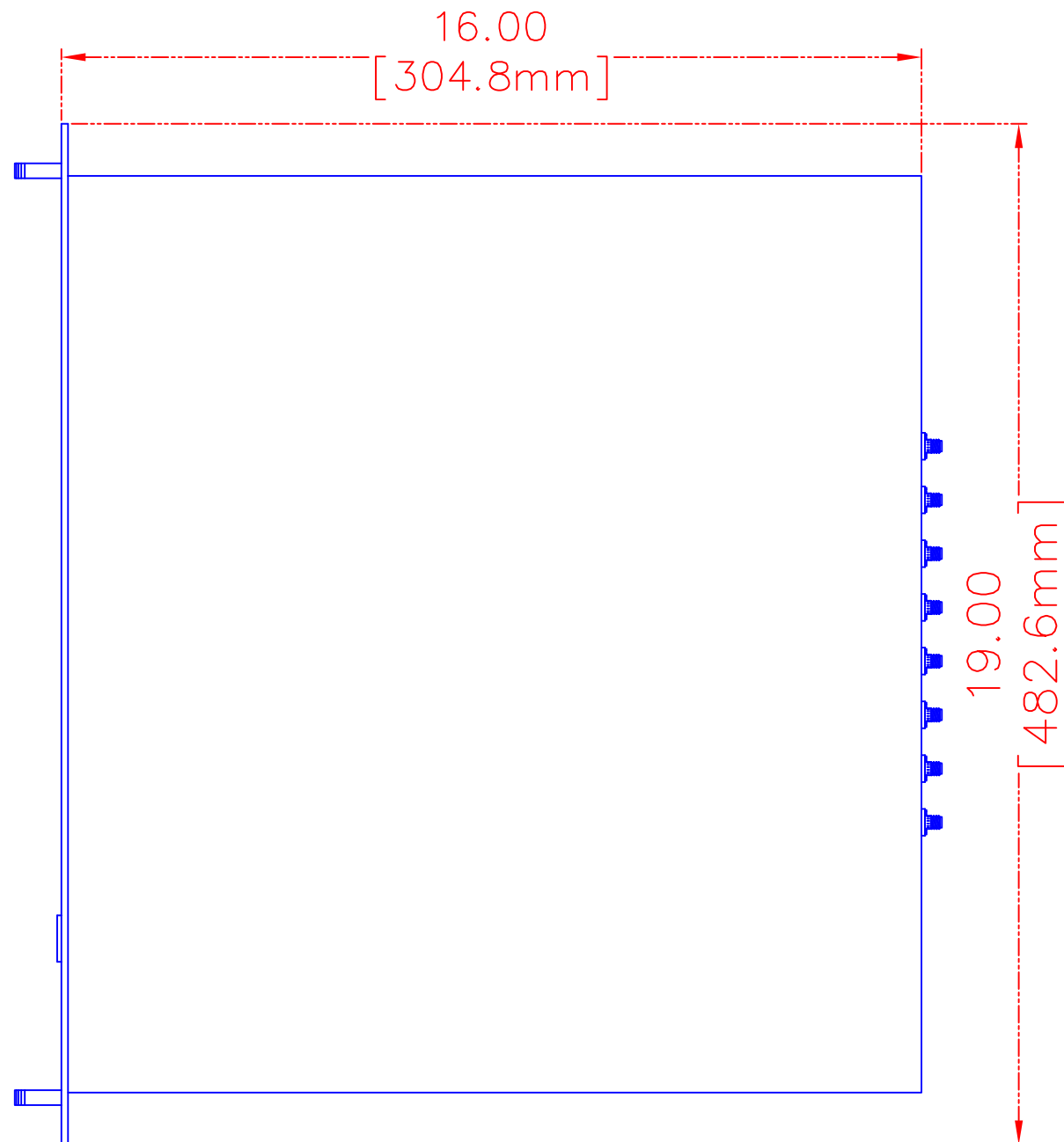
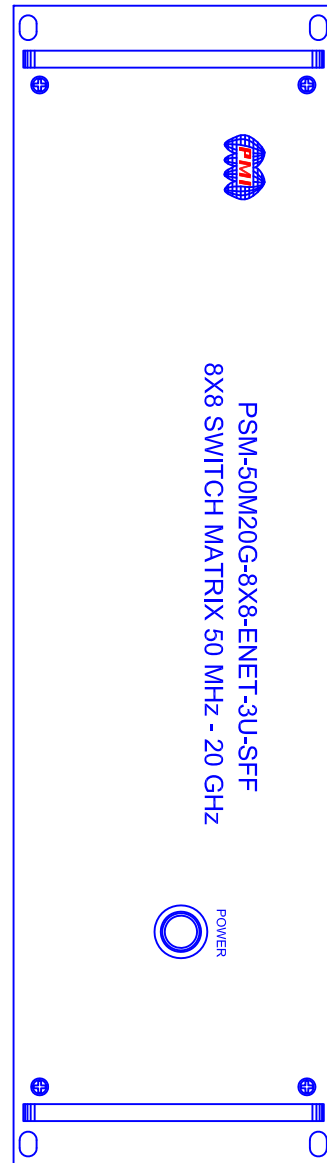

PMI CONFIDENTIAL AND PROPRIETARY

PLANAR MONOLITHICS INDUSTRIES, INC.
7311-F GROVE ROAD
FREDERICK, MARYLAND 21704 USA
TEL: 301-662-5019 FAX: 301-662-1731
WEBSITE: www.pmi-rf.com
E-MAIL: sales@pmi-rf.com
ISO 9001 CERTIFIED



APPROVALS		DATE	TITLE		
DRAWN <i>DPD</i>		8/9/21	PRODUCT FEATURE		
CHECKED			PSM-50M20G-8X8-ENET-3U-SFF		
ISSUED			SIZE	FSCM NO.	DWG NO.
			B	05XQ0	PRELIMINARY
			SCALE	N:S	SHEET 2 OF 3
					REV. 1

ALL DIMENSIONS ARE IN INCHES
TOLERANCES:
X.XX ±0.020
X.XXX ±0.010

NOTE: THE ABOVE SPECIFICATIONS ARE SUBJECT TO CHANGE OR REVISION

CONCEPTUAL BLOCK DIAGRAM:

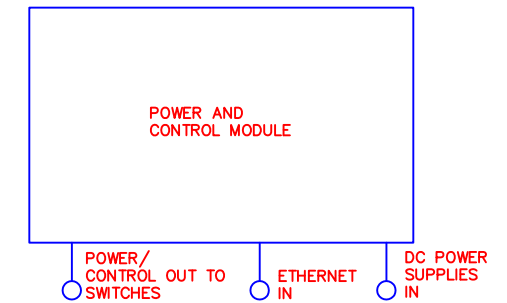
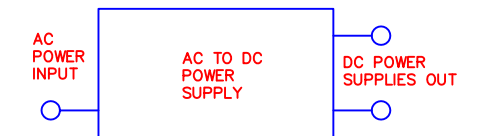
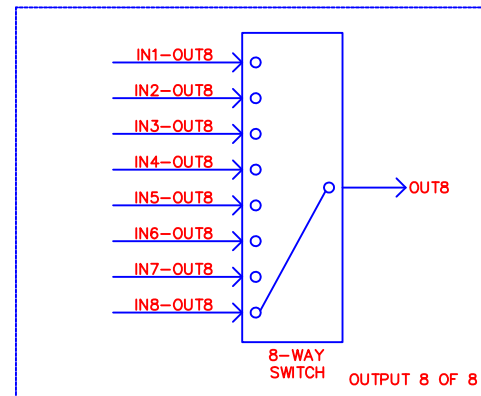
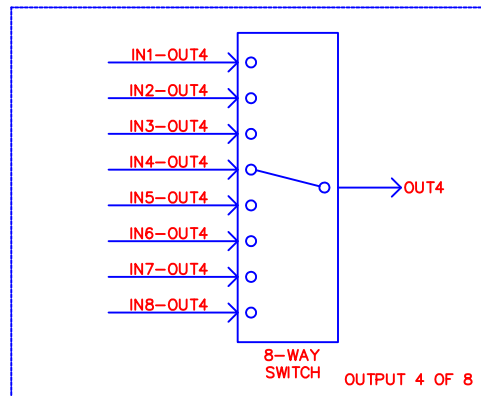
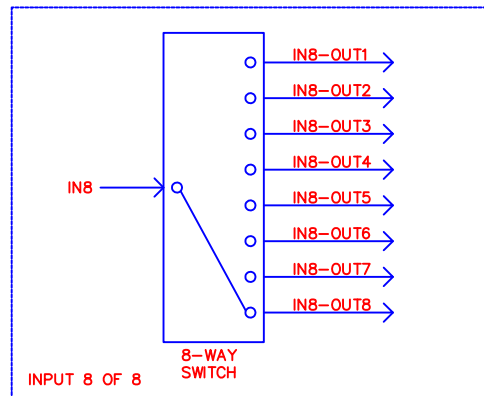
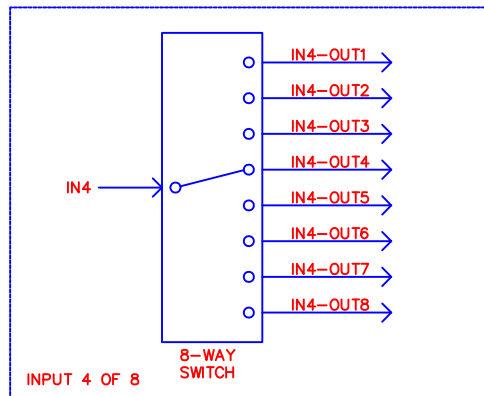
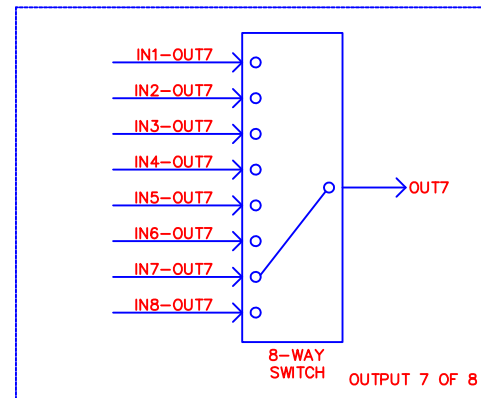
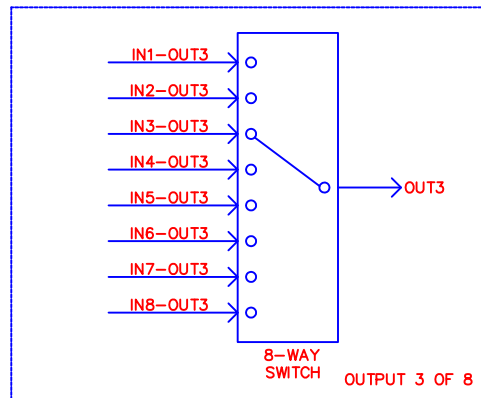
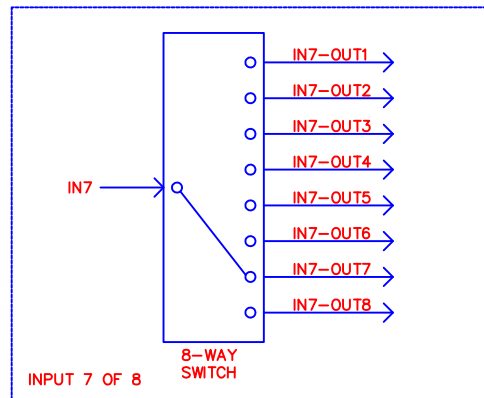
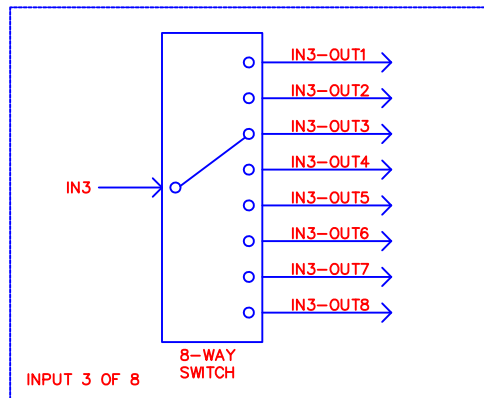
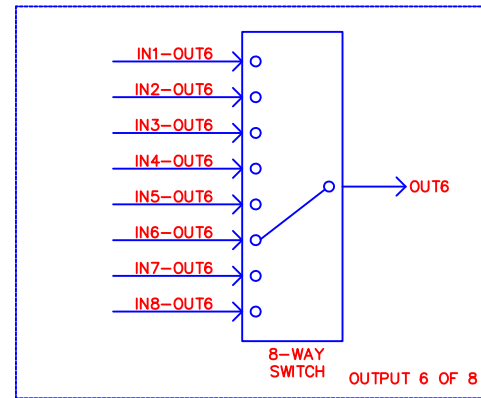
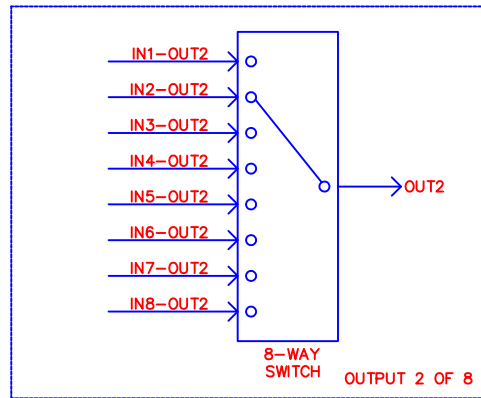
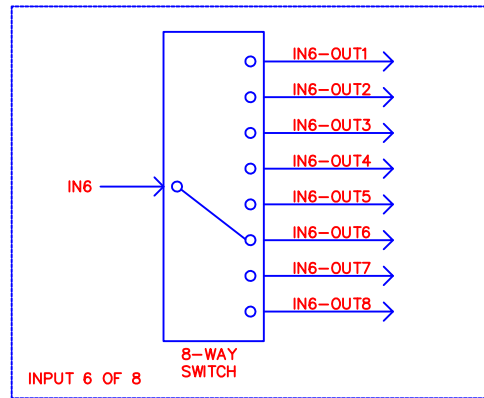
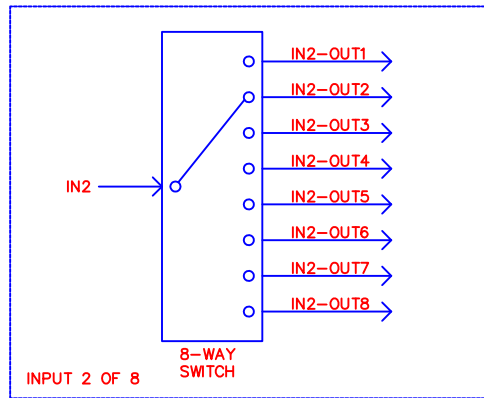
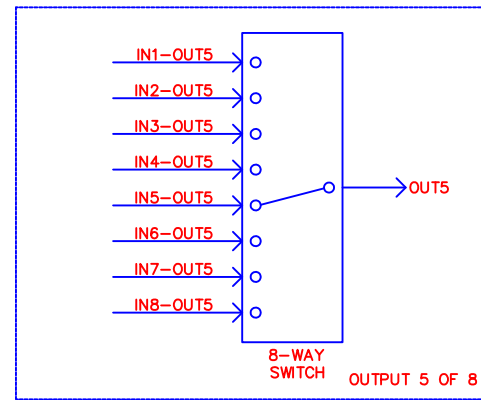
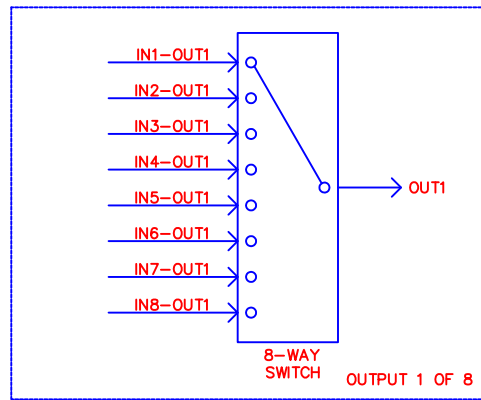
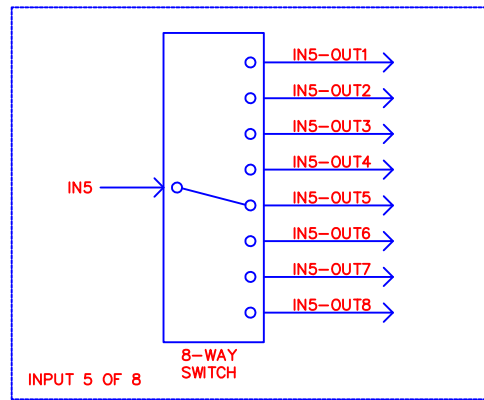
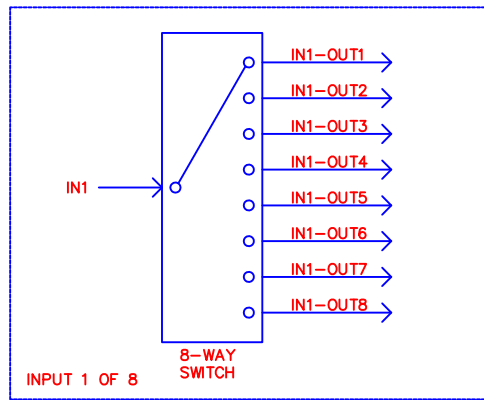

PMI CONFIDENTIAL AND PROPRIETARY

PLANAR MONOLITHICS INDUSTRIES, INC.
 7311-F GROVE ROAD
 FREDERICK, MARYLAND 21704 USA
 TEL: 301-662-5019 FAX: 301-662-1731
 WEBSITE: www.pmi-rf.com
 E-MAIL: sales@pmi-rf.com
 ISO 9001 CERTIFIED



APPROVALS		DATE	TITLE		
DRAWN <i>DPD</i>		3/9/21	PRODUCT FEATURE		
CHECKED			PSM-50M20G-8X8-ENET-3U-SFF		
ISSUED			SIZE	FSCM NO.	DWG NO.
			B	05XQ0	PRELIMINARY
			SCALE	N:S	SHEET 3 OF 3
					REV. 1

ALL DIMENSIONS ARE IN INCHES
 TOLERANCES:
 X.XX ±0.020
 X.XXX ±0.010

NOTE: THE ABOVE SPECIFICATIONS ARE SUBJECT TO CHANGE OR REVISION