

REVISIONS				
ZONE	REV.	DESCRIPTION	DATE	APPROVED
-	-	ORIGINAL RELEASE	9/28/09	

**Description:**

Low Noise Amplifier designed for Military and Industrial applications. This amplifier is supplied in our standard PE2 housings in a cascade layout that can be used as a SMA connectorized or a surface mount component. Other packages and connector types are available.

This model provides the following performance. Data is available upon request.

**Specifications:**

Frequency Range: 0.5 to 8.0 GHz  
 Gain: 60dB Typ.  
 Gain Flatness: +/-1.25dB Max.  
 Noise Figure: 4.75dB Typ.  
 OP1dB: 13dBm Min.  
 VSWR Input/Output: 2.0:1 Max.  
 DC Voltage Supply: +12 to +15VDC  
 DC Current Draw: 280mA Max.

**Features:**

Internal Voltage Regulation  
 Unconditional Stability  
 Standard Operating Temperature -20 to +70 Deg. C

**Available Options:**

Various Package types  
 Various Connector types  
 Temperature Compensation  
 Hermetic Sealing  
 Gain and Phase Matching  
 MIL-STD-883 Screening Available

**Environmental Ratings:**

Temperature: -20 to +70 Deg. C (Operating) ; -55 to +85 Deg C Available)  
 -55 to +125 Deg. C (Storage)  
 Humidity: MIL-STD-202F, METHOD 103B COND B.  
 Shock: MIL-STD-202F, METHOD 213B COND B.  
 Altitude: MIL-STD-202F, METHOD 105C COND B.  
 Temperature Cycle: MIL-STD-202F, METHOD 107D COND A

Note: The above specifications are subject to change or revision.

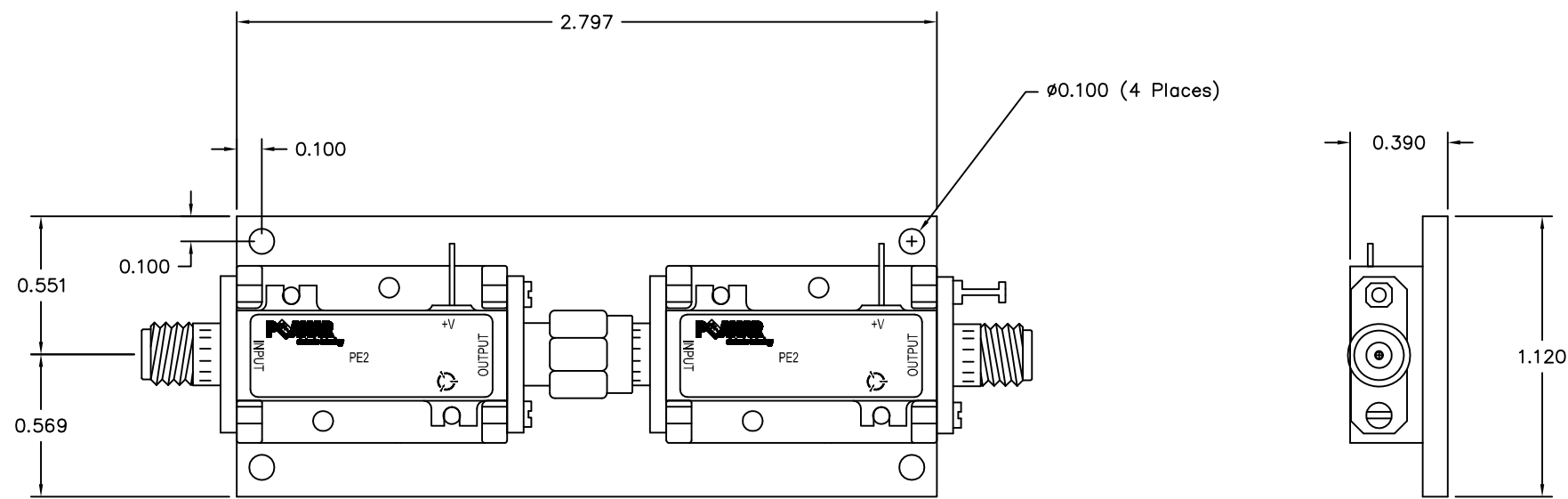

UNLESS OTHERWISE SPECIFIED  
 DIMENSIONS ARE IN INCHES  
 TOLERANCES ARE:  
 FRACTIONS DECIMALS ANGLES  
 ± .XX ± 0.010 ±  
 .XXX ± 0.005

MATERIAL: 6061-T6 Aluminum	PART NO.		 5715 Industry Lane, Unit 11 FREDERICK, MARYLAND
	APPROVALS K Mason	DATE 9/28/09	
FINISH: Gold Plate over Nickel	CHECKED		PE2-60-0R58R0-4R75-15-12-SFF-WEB SIZE B CAGE CODE 1LK53 DWG NO. WEB - MODEL REV. A SCALE N/A SHEET 1 OF 1
DO NOT SCALE DRAWING			