

DESCRIPTION

PMI MODEL RFOC-811-QRC IS A CUSTOM BUILT 8 TO 11 GHz RF SUB-SYSTEM USED TO PERFORM RF SIGNAL PROCESSING.

SPECIFICATIONS

- FREQUENCY: 8 TO 11 GHz
 - INPUT POWER:
 - AT J1005: +10 TO +20 dBm
 - AT J1013: -50 TO +20 dBm
 - AT J1006: +10 TO +15 dBm
 - AT J1016: +8 TO +13 dBm
 - AT J1017: -50 TO +20 dBm
 - AT J1011: +8 TO +13 dBm
 - AT J1008: -60 TO -10 dBm
 - OUTPUT POWER:
 - AT J1007: 11.65 dBm
 - AT J1014: -50 TO +6.92 dBm
 - AT J1015: -50 TO +5 dBm
 - AT J1012: -60 TO +13.00 dBm
 - AT J1009: -60 TO -0.35 dBm
 - AT J1010: -45.35 TO +4.65 dBm
 - POWER SUPPLY: +5V @ 5.0 A MAXIMUM
 - +15V @ 3.0 A MAXIMUM
 - 15V @ 3.0 A MAXIMUM
 - +28V @ 1.0 A MAXIMUM
 - VSWR: 2.0:1 ALL INPUT PORTS
 - 2.5:1 ALL OUTPUT PORTS
 - THROUGHPUT DELAY: 10nS MAXIMUM ALL PATHS
 - SWITCH ON/OFF: 50nS MAXIMUM
 - ATTENUATOR RISE/FALL: 1.6uS/100nS MAXIMUM
 - DEPTH OF MODULATION:
 - K1: 60dB MINIMUM
 - AT1-AT6, AT8: 50dB MINIMUM
 - AT7: 40dB MINIMUM
 - SW1-SW6, SW8: 60dB MINIMUM
 - SW7: 50dB MINIMUM
 - RF CONNECTORS: SMA FEMALE
- GAINS/LOSS:
 - GAIN J1005 TO J1014: 3dB MINIMUM
(AT8 SET TO MINIMUM, SW8 SET TO ON)
 - GAIN J1005 TO J1007: 6dB MINIMUM, 20dB MAXIMUM
(SW2 SET TO ON)
 - GAIN J1013 TO J1014: 10dB MINIMUM, 23dB MAXIMUM
(AT2 SET TO MINIMUM, AT7 AND AT8 SET TO MAXIMUM, SW7 AND SW8 SET TO OFF)
 - GAIN J1013 TO J1014: 0dB MINIMUM, 13dB MAXIMUM
(AT2 SET TO MAXIMUM, AT7 AND AT8 SET TO MINIMUM, SW7 AND SW8 SET TO ON)
 - GAIN J1013 TO J1007: 3dB MINIMUM, 16dB MAXIMUM
(AT7 SET TO MINIMUM AND SW7 SET TO ON)
 - LOSS J1006 TO J1015: 10dB MAXIMUM
(AT1 SET TO MINIMUM, SW1 SET TO ON, AND K1 SET TO ON)
 - GAIN J1006 TO J1017: 3dB MINIMUM, 20dB MAXIMUM
(AT1 SET TO MINIMUM, SW1 SET TO ON AND K1 SET TO OFF)
 - GAIN J1016 TO J1017: 3dB MINIMUM, 20dB MAXIMUM
(AT6 SET TO MINIMUM AND SW6 SET TO ON)
 - GAIN J1012 TO J1017: 3dB MINIMUM, 20dB MAXIMUM
(AT3 SET TO MINIMUM AND SW3 SET TO ON)
 - GAIN J1011 TO J1017: 3dB MINIMUM, 20dB MAXIMUM
(AT5 SET TO MINIMUM AND SW5 SET TO ON)
 - GAIN J1008 TO J1009: 6dB MINIMUM AND 16dB MAXIMUM
(AT4 SET TO MINIMUM AND SW4 SET TO ON)
 - GAIN J1008 TO J1010: 9dB MINIMUM, 19dB MAXIMUM

ENVIRONMENTAL RATINGS:

- TEMPERATURE: -55°C TO +85°C (OPERATING)
..... -65°C TO +125°C (STORAGE)
- HUMIDITY: MIL-STD-202F, METHOD 103B COND. B
- SHOCK: MIL-STD-202F, METHOD 213B COND. B
- VIBRATION: MIL-STD-202F, METHOD 204D COND. B
- ALTITUDE: MIL-STD-202F, METHOD 105C COND. B
- TEMPERATURE CYCLE: MIL-STD-202F, METHOD 107D COND. A

NOTE: SPECIFICATIONS WILL VARY OVER OPERATING TEMPERATURE
NOTE: THE ABOVE SPECIFICATIONS ARE SUBJECT TO CHANGE OR REVISION

ALL DIMENSIONS ARE IN INCHES
TOLERANCES:
X.XX ±0.020
X.XXX ±0.010

REVISIONS				
ZONE	REV.	DESCRIPTION	DATE	APPROVED
	-	ORIGINAL RELEASE JOB# P503012E	5/29/05	

PLANAR MONOLITHICS INDUSTRIES, INC.

7311-G GROVE ROAD
FREDERICK, MARYLAND 21704 USA
TEL: 301-631-1579 FAX: 301-662-2029
WEBSITE: www.planarmonolithicsindustries.com
E-MAIL: sales@planarmonolithics.com
ISO 9001:2000 CERTIFIED



APPROVALS		DATE	TITLE			
DRAWN <i>JKM & YR</i>		4/5/06	PRODUCT FEATURE RFOC-811-QRC 8 - 11 GHz RF SUB-SYSTEM USED TO PERFORM RF SIGNAL PROCESSING			
CHECKED			SIZE A	FSCM NO. 0ZXZ8	DWG NO. 100-7424	REV. -
ISSUED			SCALE N:S		SHEET 1 OF 3	

DESCRIPTION

PMI MODEL RFOC-811-QRC IS A CUSTOM BUILT 8 TO 11 GHz RF SUB-SYSTEM USED TO PERFORM RF SIGNAL PROCESSING.

REVISIONS				
ZONE	REV.	DESCRIPTION	DATE	APPR
	-	ORIGINAL RELEASE JOB# P503012E	5/29/05	

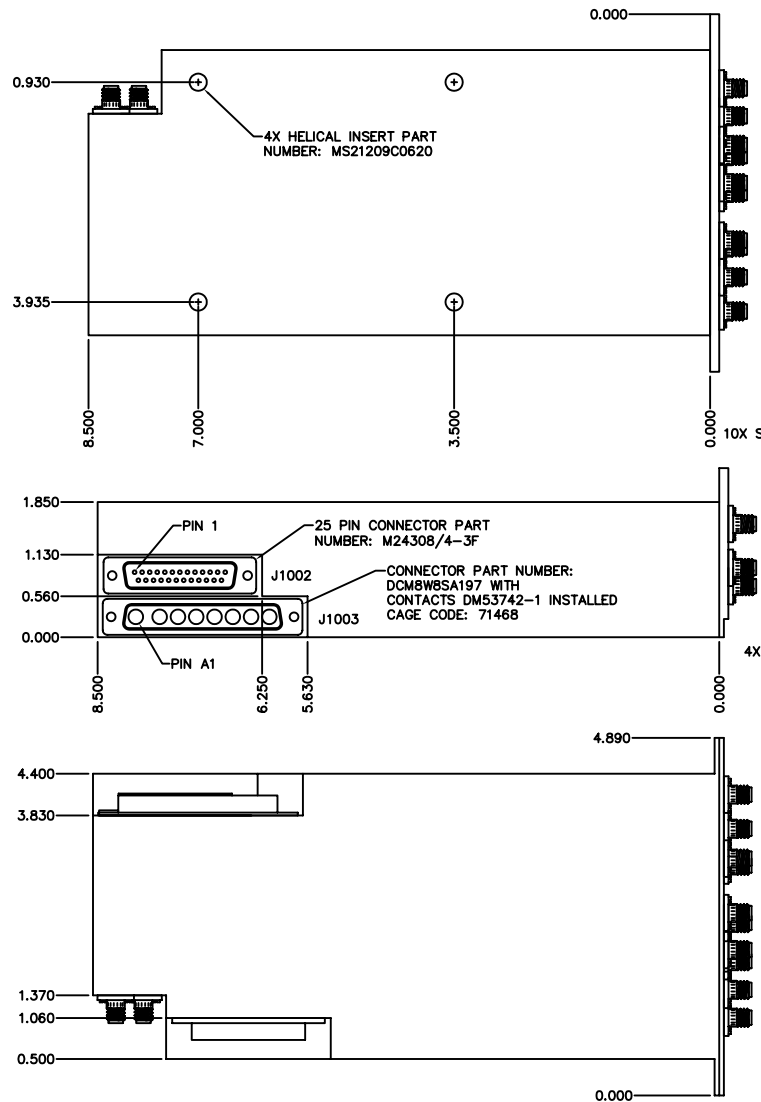

PINOUT FOR CONNECTOR J1002	
PIN NO.	FUNCTIONAL DESCRIPTION
PIN 1	K1 RELAY CMD
PIN 2	GROUND
PIN 3	GROUND
PIN 4	+5 VDC
PIN 5	+5 VDC
PIN 6	+5 VDC
PIN 7	GROUND
PIN 8	GROUND
PIN 9	GROUND
PIN 10	-15 VDC
PIN 11	-15 VDC
PIN 12	-15 VDC
PIN 13	-15 VDC
PIN 14	-15 VDC
PIN 15	GROUND
PIN 16	+28 VDC
PIN 17	GROUND
PIN 18	+15 VDC
PIN 19	+15 VDC
PIN 20	+15 VDC
PIN 21	+15 VDC
PIN 22	+15 VDC
PIN 23	+15 VDC
PIN 24	GROUND
PIN 25	GROUND

PINOUT FOR CONNECTOR J1004	
PIN NO.	FUNCTIONAL DESCRIPTION (INPUTS 0 - 10 VDC)
PIN 1	REPEATER INPUT ATTENUATOR CONTROL; AT2
PIN 2	SHIELD GROUND FOR SIGNAL AT PIN 1
PIN 3	DRFM INPUT ATTENUATOR CONTROL; AT4
PIN 4	SHIELD GROUND FOR SIGNAL AT PIN 3
PIN 5	DRFM OUTPUT ATTENUATOR CONTROL; AT6
PIN 6	SHIELD GROUND FOR SIGNAL AT PIN 5
PIN 7	IFMSOR ATTENUATOR CONTROL; AT5
PIN 8	SHIELD GROUND FOR SIGNAL AT PIN 7
PIN 9	RGPO ATTENUATOR CONTROL; AT8
PIN 10	SHIELD GROUND FOR SIGNAL AT PIN 9
PIN 11	SPOT NOISE ATTENUATOR CONTROL; AT1
PIN 12	SHIELD GROUND FOR SIGNAL AT PIN 11
PIN 13	REPEATER OUTPUT ATTENUATOR CONTROL; AT3
PIN 14	SHIELD GROUND FOR SIGNAL AT PIN 13
PIN 15	LOOP INPUT ATTENUATOR CONTROL; AT7
PIN 16	SHIELD GROUND FOR SIGNAL AT PIN 15
PIN 17	N/A
PIN 18	N/A
PIN 19	N/A
PIN 20	N/A
PIN 21	N/A
PIN 22	N/A
PIN 23	N/A
PIN 24	N/A
PIN 25	N/A

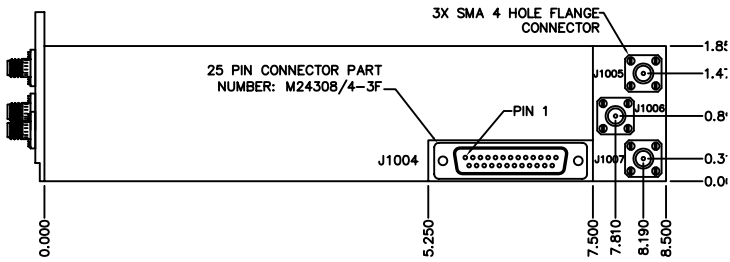
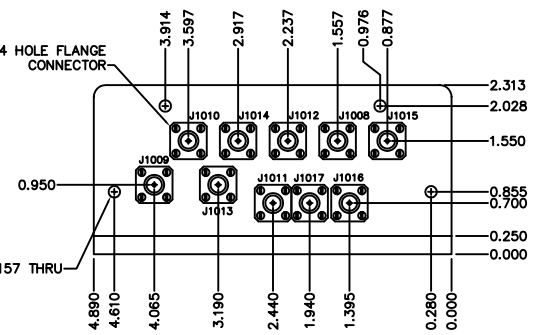

PINOUT FOR CONNECTOR J1003	
PIN NO.	FUNCTIONAL DESCRIPTION (ALL TTL INPUT)
PIN A1	LOOP INPUT ENABLE SWITCH CONTROL; SW-7
PIN A2	LOOP FILL ENABLE SWITCH CONTROL; SW-2
PIN A3	DELAY LINE RGPO SWITCH CONTROL; SW-8
PIN A4	CHOP AM SWITCH CONTROL; SW-4
PIN A5	IFMSOR AM SWITCH CONTROL; SW-5
PIN A6	DRFM AM SWITCH CONTROL; SW-6
PIN A7	NOISE AM SWITCH CONTROL; SW-1
PIN A8	REPEATER AM SWITCH CONTROL; SW-3

MECHANICAL OUTLINE

PLANAR MONOLITHICS INDUSTRIES, INC.

7311-G GROVE ROAD
 FREDERICK, MARYLAND 21704 USA
 TEL: 301-631-1579 FAX: 301-662-2029
 WEBSITE: www.planarmonolithicsindustries.com
 E-MAIL: sales@planarmonolithics.com
 ISO 9001:2000 CERTIFIED



ALL DIMENSIONS ARE IN INCHES
 TOLERANCES:
 X.XX ±0.020
 X.XXX ±0.010

APPROVALS		DATE	TITLE		
DRAWN <i>JKM & YR</i>		4/5/06	MECHANICAL OUTLINE RFOC-811-QRC		
CHECKED			8 - 11 GHz RF SUB-SYSTEM USED TO PERFORM RF SIGNAL PROCESSING		
ISSUED			SIZE A	FSCM NO. 0ZXZ8	DWG NO. 100-7424
			SCALE N:S	SHEET 2 OF	

FUNCTIONAL BLOCK DIAGRAM

REVISIONS				
ZONE	REV.	DESCRIPTION	DATE	APPROVED
		- ORIGINAL RELEASE JOB# P503012E	5/29/05	

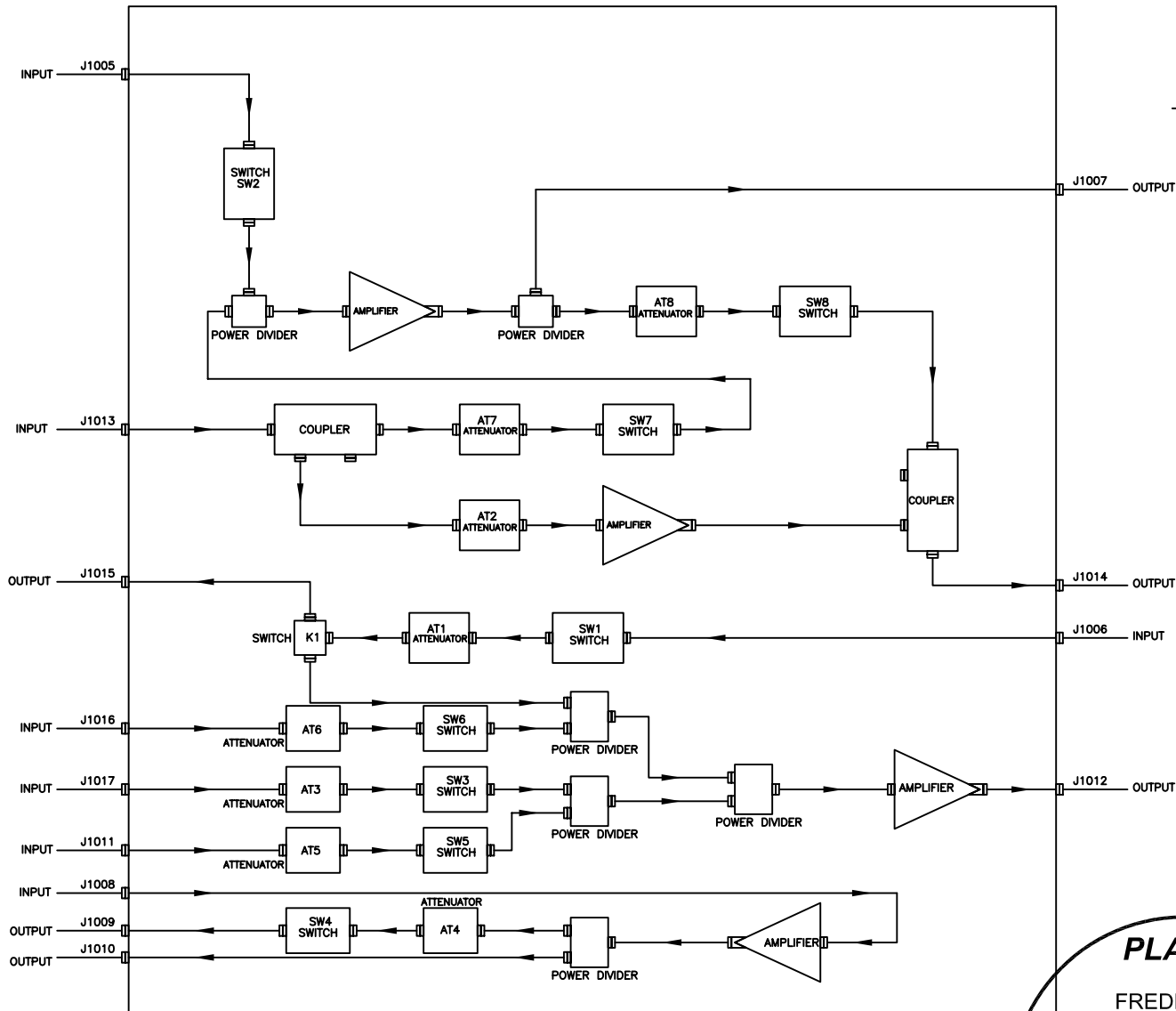

DESCRIPTION

PMI MODEL RFOC-811-QRC IS A CUSTOM BUILT 8 TO 11 GHz RF SUB-SYSTEM USED TO PERFORM RF SIGNAL PROCESSING.

PLANAR MONOLITHICS INDUSTRIES, INC.

7311-G GROVE ROAD
 FREDERICK, MARYLAND 21704 USA
 TEL: 301-631-1579 FAX: 301-662-2029
 WEBSITE: www.planarmonolithicsindustries.com
 E-MAIL: sales@planarmonolithics.com
 ISO 9001:2000 CERTIFIED



APPROVALS		DATE	TITLE		
DRAWN <i>JKM & YR</i>		4/5/06	FUNCTIONAL BLOCK DIAGRAM RFOC-811-QRC 8 - 11 GHz RF SUB-SYSTEM USED TO PERFORM RF SIGNAL PROCESSING		
CHECKED			SIZE A	FSCM NO. 0ZXZ8	DWG NO. 100-7424
ISSUED			SCALE N:S		SHEET 3 OF 3