

8 7 6 5 4 3 2 1

Description:

Low Noise Amplifier designed for Military and Industrial applications. This amplifier is supplied in our standard PE2 housing that can be used as a SMA connectorized or a surface mount component. Other packages and connector types are available.

This model provides the following performance. Data is available upon request.

Specifications:

Frequency Range:	2.0 to 10.0 GHz
Gain:	30dB Typ.
Gain Flatness:	+/-1.0dB Max.
Noise Figure:	4.0dB Typ.
OP1dB:	13dBm Min.
VSWR Input/Output:	2.0:1 Max.
DC Voltage Supply:	+12 to +15VDC
DC Current Draw:	130mA Max.

Features:

- Internal Voltage Regulation
- Unconditional Stability
- Standard Operating Temperature -20 to +70 Deg. C

Available Options:

- Various Package types
- Various Connector types
- Temperature Compensation
- Hermetic Sealing
- Gain and Phase Matching
- MIL-STD-883 Screening Available

Environmental Ratings:

Temperature:	-20 to +70 Deg. C (Operating) ; -55 to +85 Deg C Available)
	-55 to +125 Deg. C (Storage)
Humidity:	MIL-STD-202F, METHOD 103B COND B.
Shock:	MIL-STD-202F, METHOD 213B COND B.
Altitude:	MIL-STD-202F, METHOD 105C COND B.
Temperature Cycle:	MIL-STD-202F, METHOD 107D COND A

Note: The above specifications are subject to change or revision.

REVISIONS				
ZONE	REV.	DESCRIPTION	DATE	APPROVED
-	-	ORIGINAL RELEASE	2/1/08	

PE2 HOUSING WITH CARRIER

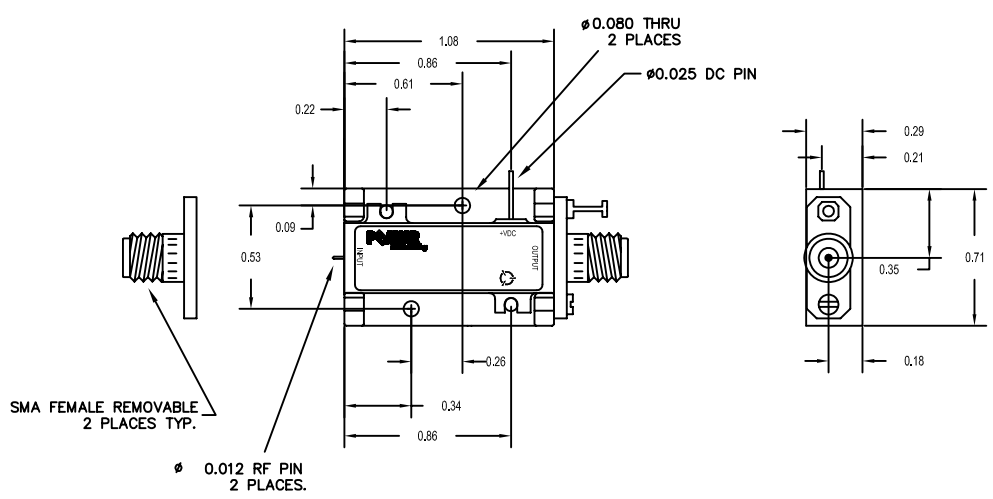

PE2 HOUSING WITHOUT CARRIER (SURFACE MOUNT)

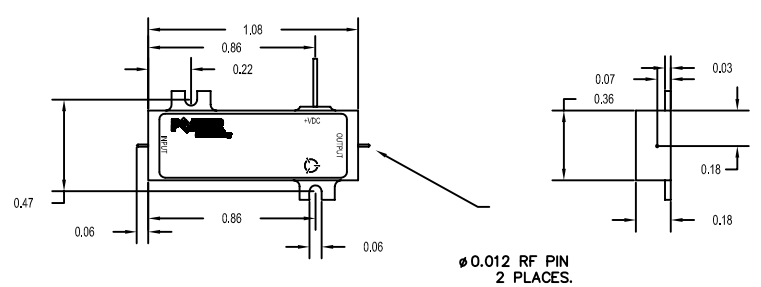

UNLESS OTHERWISE SPECIFIED DIMENSIONS ARE IN INCHES TOLERANCES ARE: FRACTIONS DECIMALS ANGLES ± .XX ± 0.010 ± .XXX ± 0.005

MATERIAL: 6061-T6 Aluminum	APPROVALS	DATE	5715 Industry Lane, Unit 11 FREDERICK, MARYLAND
	DRAWN K Mason	2/21/08	
FINISH: Gold Plate over Nickel	CHECKED		TITLE PRODUCT FEATURE PE2-30-2R010R0-4R0-15-12-SFF
	DRAWN		
DO NOT SCALE DRAWING	SIZE CASE CODE B 1LK53	PWB NO.	WEB - MODEL A
	SCALE N/A		SHEET 1 OF 1

8 7 6 5 4 3 2 1