

DESCRIPTION

PMI MODEL: LD-50-SHS-N-1-SFM IS A HIGH SPEED, HIGH POWER, HIGH SENSITIVITY HARD DIODE LIMITER-DETECTOR. IT OPERATES OVER THE FREQUENCY RANGE OF 0.5 TO 18GHz

SPECIFICATIONS

- FREQUENCY RANGE: 0.5 TO 18 GHz
- FREQUENCY FLATNESS: ± 1.5 dB MAX, ± 1.0 dB TYP
- VSWR: 3.5:1 MAX
- VIDEO CAPACITANCE: 10 pF
- SPEED: 10ns
- INPUT POWER: 1W CW MAX. (+40 dBm PEAK, 1us)
- VOLTAGE SENSITIVITY: 700 mV/mW
- TANGENTIAL SENSITIVITY: -50dBm @ 2 MHz VIDEO BANDWIDTH
- CONNECTORS: SMA FEMALE (INPUT) / MALE (OUTPUT)
- FINISH: BLUE EPOXY POLIMIDE COATING IAW MIL-C-22750, TYPE I OVER EPOXY POLIMIDE PRIMER IAW MIL-P-23377, TYPE I, CLASS 1 OR 3.
- SIZE: 0.5" X 0.5" X 0.22"

ENVIRONMENTAL RATINGS

- TEMPERATURE: -54°C TO +85°C (OPERATING)
-65°C TO +125°C (STORAGE)
- HUMIDITY: MIL-STD-202F, METHOD 103B COND. B
- SHOCK: MIL-STD-202F, METHOD 213B COND. B
- VIBRATION: MIL-STD-202F, METHOD 204D COND. B
- ALTITUDE: MIL-STD-202F, METHOD 105C COND. B
- TEMPERATURE CYCLE: MIL-STD-202F, METHOD 107D COND. A

NOTE: SPECIFICATIONS WILL VARY OVER OPERATING TEMPERATURE
NOTE: THE ABOVE SPECIFICATIONS ARE SUBJECT TO CHANGE OR REVISION

ALL DIMENSIONS ARE IN INCHES
TOLERANCES:
X.XX ± 0.020
X.XXX ± 0.010
WEIGHT: X.XX oz.

REVISIONS				
ZONE	REV.	DESCRIPTION	DATE	APPROVED
	-	PRELIMINARY	9/22/20	

PMI CONFIDENTIAL AND PROPRIETARY

PLANAR MONOLITHICS INDUSTRIES, INC.

7311-F GROVE ROAD
FREDERICK, MARYLAND 21704 USA
TEL: 301-662-5019 FAX: 301-662-1731
WEBSITE: www.pmi-rf.com
E-MAIL: sales@pmi-rf.com
ISO 9001 CERTIFIED



APPROVALS		DATE	TITLE			REV.
DRAWN	JPP	9/22/20	PRODUCT FEATURE LD-50-SHS-N-1-SFM HARD LIMITER-DETECTOR			-
CHECKED			SIZE	FSCM NO.	DWG NO.	
ISSUED			A	05XQ0	PRELIMINARY	
			SCALE	N:S	SHEET	1 OF 2

MECHANICAL DIMENSIONS

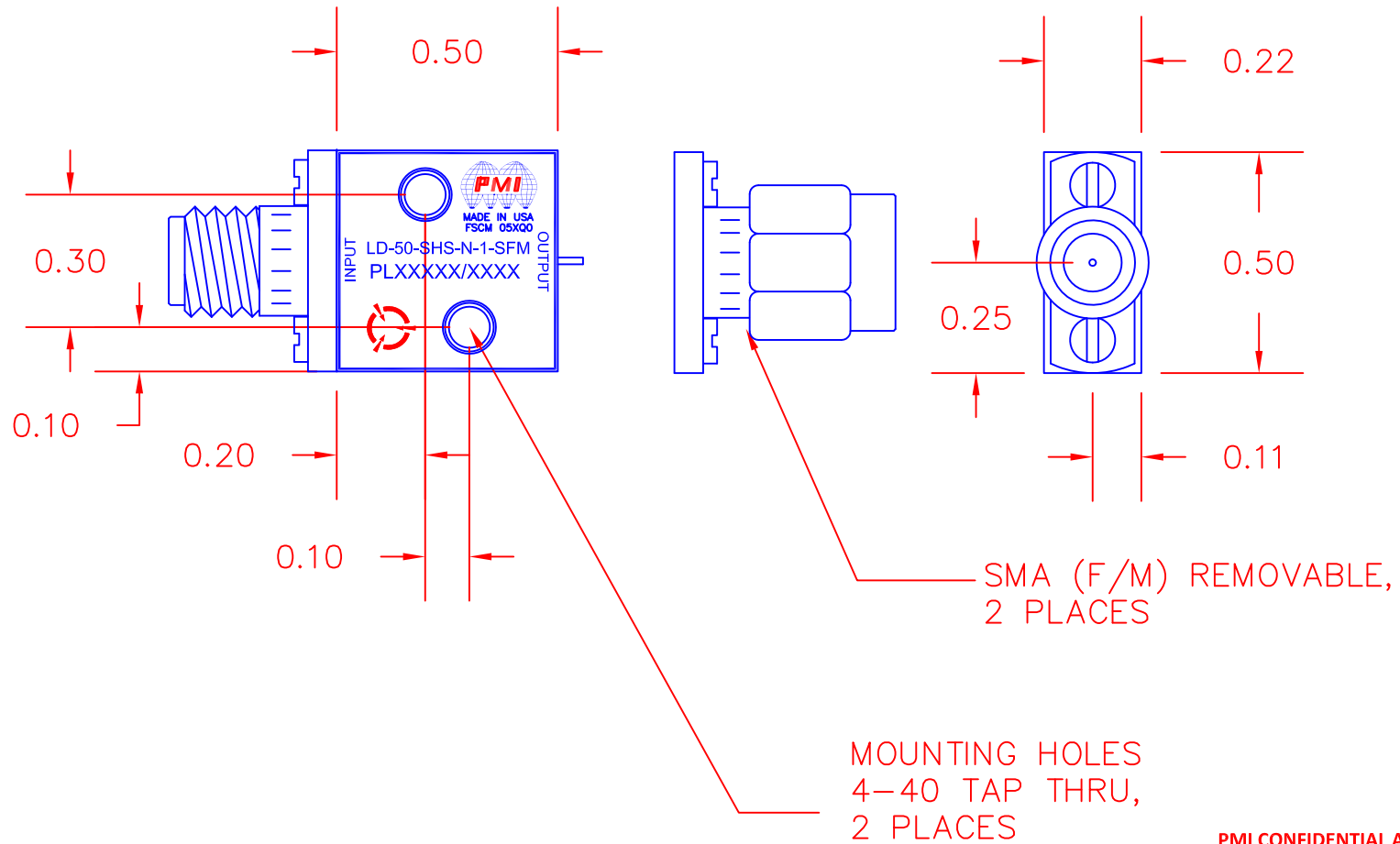

PMI CONFIDENTIAL AND PROPRIETARY

PLANAR MONOLITHICS INDUSTRIES, INC.
 7311-F GROVE ROAD
 FREDERICK, MARYLAND 21704 USA
 TEL: 301-662-5019 FAX: 301-662-1731
 WEBSITE: www.pmi-rf.com
 E-MAIL: sales@pmi-rf.com
 ISO 9001 CERTIFIED



ALL DIMENSIONS ARE IN INCHES
 TOLERANCES:
 X.XX ±0.020
 X.XXX ±0.010
 WEIGHT: X.XX oz.

APPROVALS		DATE	TITLE			
DRAWN		9/22/20	PRODUCT FEATURE LD-50-SHS-N-1-SFM HARD LIMITER-DETECTOR			
CHECKED			SIZE	FSCM NO.	DWG NO.	REV.
ISSUED			A	05XQ0	PRELIMINARY	-
			SCALE	N:S	SHEET	2 OF 2