

MegaCap Type (BC Series)

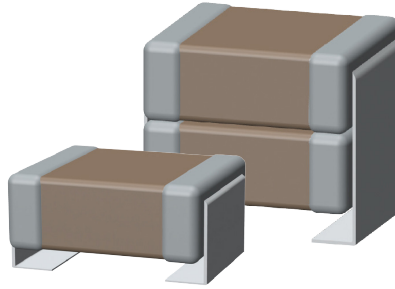

Features

- Higher capacitance on same footprint
- C0G and X7R dielectrics
- Voltages up to 1000V
- High mechanical & thermal endurance
- Excellent vibration performance
- AEC-Q200 options available
- RoHS compliant

Applications

- Industrial smoothing & decoupling
- Resonant charging systems
- DC to DC converters
- High voltage coupling/DC blocking
- Power supplies
- Snubbers in high frequency power converters

Product Overview

Quantic's UTC's MegaCap Type (BC Series) technology in a leaded and stacked format, delivers capacitance performance typically associated with much larger footprints. The leaded configuration reduces strain on the part in stressful mechanical and thermal environments. This rugged configuration, coupled with high capacitance values and with available voltages to 1000V makes this an excellent choice for industrial and automotive environments. Available in both C0G and X7R dielectrics, single and multi-chip stacks with J- & L-tab leads. Custom configurations and higher capacitances are also available.

Part Ordering

BC	1	S	2220	J	1	X7R	105	M	T	-	A1N
Series	No. Chip(s)	Voltage Code	Case Code	Lead Type	Coating	Dielectric	Capacitance	Tolerance	Packaging	Test Level	Special Code
MegaCap Type	1	G = 50VDC	1210	J = Formed In	1 =	X7R	102 = 1000pF	J = ±5%	Tape & Reel		AEC-Q200 = A1N*
	2	B = 100VDC	1812	L = Formed	Uncoated	C0G	103 = 10,000pF	K = ±10%	Tray		
	3	R = 200VDC	1825	Out			223 = 22,000pF	M = ±20%			
		H = 250VDC	2220				225 =				
		S = 500VDC	2225				2,200,000pF				
		K = 630VDC					(or 2.2µF)				
		W = 1000VDC									

*A for AEC-Q200

1 or 0 for product level per AEC-Q200

N for no-coating or C for surface-coating

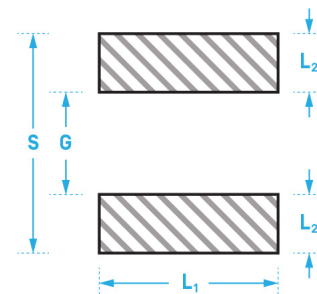
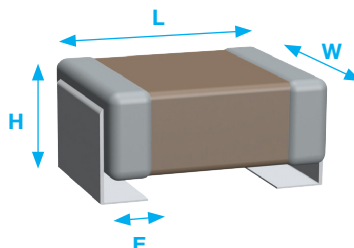
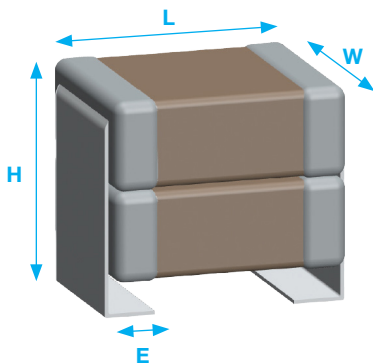

Standard Dimensions

Landing Pad Dimensions

Case Size	No. Chips	Length (L)	Width (W)	Height (H)	Tab Length (E)	S	L1	L2	G
1210 (3225)	1	0.138±0.016 (3.50±0.40)	0.098±0.016 (2.50±0.40)	*	0.043±0.006 (1.10±0.15)	0.193 (4.90)	0.110 (2.80)	0.055 (1.40)	0.083 (2.10)
	2	N/A	N/A	N/A	N/A				
1812 (4532)	1	0.189±0.016 (4.80±0.40)	0.126±0.016 (3.20±0.40)	*	0.055±0.006 (1.40±0.15)	0.268 (6.80)	0.150 (3.80)	0.063 (1.60)	0.142 (3.60)
	2	0.189±0.016 (4.80±0.40)	0.126±0.016 (3.20±0.40)	*	0.055±0.006 (1.40±0.15)				
1825 (4563)	1	0.189±0.016 (4.80±0.40)	0.248±0.20 (6.30±0.50)	*	0.067±0.006 (1.70±0.15)	0.268 (6.80)	0.268 (6.80)	0.063 (1.60)	0.142 (3.60)
	2	0.189±0.016 (4.80±0.40)	0.248±0.20 (6.30±0.50)	*	0.067±0.006 (1.70±0.15)				
2220 (5750)	1	0.236±0.016 (6.00±0.40)	0.197±0.20 (5.00±0.50)	*	0.067±0.006 (1.70±0.15)	0.331 (8.40)	0.217 (5.50)	0.087 (2.20)	0.157 (4.00)
	2	0.236±0.016 (6.00±0.40)	0.197±0.20 (5.00±0.50)	*	0.067±0.006 (1.70±0.15)				
2225 (5763)	1	0.236±0.016 (6.00±0.40)	0.248±0.020 (6.30±0.50)	*	0.067±0.006 (1.70±0.15)	0.331 (8.40)	0.268 (6.80)	0.087 (2.20)	0.157 (4.00)
	2	0.236±0.016 (6.00±0.40)	0.248±0.020 (6.30±0.50)	*	0.067±0.006 (1.70±0.15)				

* For height, refer to the individual size/capacitance chart.

Dielectric Properties & Electrical Summary

Dielectric	NPO (Class I)	X7R (Class II)
Case Size	1210, 1812, 1825, 2220, 2225	
Capacitance ¹	1,000pF to 220,000pF	10,000pF to 47,000,000pF
Capacitance Tolerance	Single Chip: J(±5%), K(±10%), M(±20%) Two-Chip Stack: M(±20%)	
Rated Voltages (WVDC)	50V, 100V, 200V, 250V, 500V, 630V, 1000V	
Insulation Resistance	≥10GΩ@25°C or ≥100GΩ@125°C	
Operating Temperature	-55°C to +125°C	
Capacitance Change (TC)	±30ppm/°C	±15%
Dissipation Factor (DF)	0.10% Max	1210 > 4.7μF = 5.0% Max 1812-2225 ≥ 2.2μF = 5.0% Max All other values = 2.5% Max

1. Measured at 1.0±0.2Vrms, 1.0kHz±10% for capacitance > 1,000pF.

2. Measured at 25°C and between 30% to 70% relative humidity.

Available Capacitance Values

Case Size	No. Chips	Max Capacitance Rating (µF) for NPO Dielectric							Max Capacitance Rating (µF) for X7R Dielectric							
		50V	100V	200V	250V	500V	630V	Height (H) inch (mm)	50V	100V	200V	250V	500V	630V	1000V	Height (H) inch (mm)
1210	-1	0.039	0.022	0.010	0.010	0.010	0.010	.142±.013 (3.60±0.35)	4.7	3.3	0.7	0.7	0.1	0.1		.142±.013 (3.60±0.35)
	-2	N/A	N/A	N/A	N/A	N/A	N/A	N/A	N/A	N/A	N/A	N/A	N/A	N/A	N/A	N/A
1812	-1	0.100	0.047	0.027	0.027	0.022	0.022	.142±.013 (3.60±0.35)	10.0	4.7	1.0	1.0	0.5	0.2		.142±.013 (3.60±0.35)
	-2	0.220	0.100	0.056	0.056	0.047	0.047	.236±.013 (6.00±0.35)	22.0	10.0	2.2	2.2	1.0	0.5		.236±.013 (6.00±0.35)
1825	-1	0.100	0.100	0.068	0.068	0.047	0.022	.142±.013 (3.60±0.35)	10.0	10.0	1.0	1.0	0.6	0.6		.142±.013 (3.60±0.35)
	-2	0.220	0.220	0.120	0.120	0.100	0.047	.236±.013 (6.00±0.35)	22.0	22.0	2.2	2.2	1.2	1.2		.236±.013 (6.00±0.35)
2220	-1	0.100	0.100	0.068	0.068	0.047	0.022	.142±.013 (3.60±0.35)	22.0	10.0	2.2	2.2	0.5	0.5		.142±.013 (3.60±0.35)
	-2	0.220	0.220	0.120	0.120	0.100	0.047	.236±.013 (6.00±0.35)	47.0	22.0	4.7	4.7	1.0	1.0	1.0	.260±.013 (6.60±0.35)
2225	-1	0.100	0.100	0.100	0.100	0.082	0.068	.142±.013 (3.60±0.35)	10.0	10.0	2.7	2.7	0.6	0.6		.142±.013 (3.60±0.35)
	-2	0.220	0.220	0.220	0.220	0.180	0.120	.236±.013 (6.00±0.35)	22.0	22.0	5.6	5.6	1.2	1.2	0.5	.236±.013 (6.00±0.35)

Test Conditions

Item	Test Condition	Requirements
1. Visual & Dimensions	<ul style="list-style-type: none"> Suitable optical or mechanical measurement system 	<ul style="list-style-type: none"> No major defects Conforms to individual specification sheet
2. Capacitance	<ul style="list-style-type: none"> For capacitance values > 1000pF: 1.0 ±0.2Vrms, 1.0kHz ±10% Measured at room temperature 	<ul style="list-style-type: none"> Shall not exceed specified capacitance plus allowed tolerance
3. DF	<ul style="list-style-type: none"> For capacitance values > 1000pF: 1.0 ±0.2Vrms, 1.0kHz ±10% Measured at room temperature 	<ul style="list-style-type: none"> C0G: 0.10% Max X7R: <ul style="list-style-type: none"> 1210 > 2.2µF = 5.0% Max 1812 – 2225 ≥ 4.7µF = 5.0% Max All Other Values = 2.5% Max
4. Dielectric Strength	<ul style="list-style-type: none"> Applied voltage: <ul style="list-style-type: none"> ≤100V : 250% of rated voltage 100 < V ≤ 250V : 200% rated voltage 250 < V ≤ 500V : 150% rated voltage Duration: 1 to 5 sec. Charge & discharge current <50mA 	<ul style="list-style-type: none"> No evidence of damage or arc-over during test
5. Insulation Resistance	<ul style="list-style-type: none"> Time rated voltage applied <ul style="list-style-type: none"> ≤100V □ max. 120 sec. >100V □ max 60 sec. (Max 500V) Test at room temperature 	<ul style="list-style-type: none"> ≥10GΩ or RxC≥100Ω-F whichever is smaller
6. Temperature Coefficient	<ul style="list-style-type: none"> No electrical load Allow temperature to equilibrate prior to measure 	<ul style="list-style-type: none"> Capacitance change within: <ul style="list-style-type: none"> → C0G: ±30ppm/°C from -55 to 125°C at 25°C → X7R: ±15% from -55 to 125°C at 25°C
7. Termination Adhesion Strength	<ul style="list-style-type: none"> Capacitors mounted on a substrate 10N Force applied central & perpendicular to the device and parallel to the substrate Test time: 10 ±1 sec. 	<ul style="list-style-type: none"> No major damage or removal of termination
8. Vibration Resistance	<ul style="list-style-type: none"> Vibration frequency: 10 to 55 Hz cycle Total amplitude: 1.5mm Test time: 6 hrs. (Two hrs. each in three mutually perpendicular directions.) Cap./DF Measurement to be made after de-aging at 150°C for 1hr then set for 24 ±2 hrs. at room temp. 	<ul style="list-style-type: none"> No major damage Capacitance change, DF to meet initial specification
9. Solderability	<ul style="list-style-type: none"> Solder temperature: 235±5°C Dipping time: 2±0.5 sec. 	<ul style="list-style-type: none"> 95% min. coverage of all metalized area
10. Bend Test	<ul style="list-style-type: none"> Force applied to middle of substrate and normal to the substrate surface at a rate of approx. 1mm/s until 1mm deflection achieved, pressure maintained for 5 ±1 sec. 	<ul style="list-style-type: none"> No major damage Capacitance change before and after test within <ul style="list-style-type: none"> C0G → ±3.0% or ±2.0pF (whichever is larger) X7R → within 12.5%

Test Conditions (cont.)

Item	Test Condition	Requirements
11. Resistance to Soldering Heat	<ul style="list-style-type: none"> ▪ Solder temperature: 260 ±5°C ▪ Dipping time: 10 ±1 sec ▪ Preheating: 120-150°C for 1 min before immersion ▪ Cap. / DF / I.R. Measurement to be made after deaging at 150°C for 1hr. then 24hr. age at RT 	<ul style="list-style-type: none"> ▪ No major damage ▪ Capacitance change: within ±2.5% or ±0.25pF whichever is larger ▪ D.F., I.R. and dielectric strength meet initial spec ▪ 25% max. leaching on each edge
12. Temperature Cycle	<ul style="list-style-type: none"> ▪ Conduct 5 cycles: <ol style="list-style-type: none"> 1. Min operating temp: +0/-3°C for 30±3mins 2. Room temp for 2-3mins 3. Max operating temp: +0/-3°C for 30 ±3mins. 4. Room Temp for 2-3 mins. ▪ Cap. / DF / I.R. Measurement to be made after de-aging at 150°C for 1hr then 24±2hr age at RT 	<ul style="list-style-type: none"> ▪ No major defects ▪ Cap change: <ul style="list-style-type: none"> C0G → within ±2.5% or ±0.25pF whichever is larger X7R → within 7.5% ▪ D.F. <ul style="list-style-type: none"> C0G → = initial requirement X7R → dF≤150% initial requirement ▪ I.R.: To meet initial requirements
13. Humidity (Steady State)	<ul style="list-style-type: none"> ▪ Test temp.: 40±2°C ▪ Humidity: 90~95% RH ▪ Test time: 500+24/-0hrs. ▪ Cap. / DF(Q) / I.R. Measurement to be made after de-aging at 150°C for 1hr then 24±2hr age at RT 	<ul style="list-style-type: none"> ▪ No major damage ▪ Cap change: within ±5.0% or ±0.5pF whichever is larger. ▪ Q/D.F. value: <ul style="list-style-type: none"> → C0G: Q≥100% of initial requirement → X7R: dF≤150% of initial requirement ▪ I.R.: ≥1GΩ or RC≥50ΩF, whichever is smaller
14. Humidity (Under Load)	<ul style="list-style-type: none"> ▪ Test temp.: 40±2°C ▪ Humidity: 90~95%RH ▪ Test time: 500+24/-0 hrs. ▪ Applied voltage: rated voltage (MAX. 500V) ▪ Cap. / DF / I.R. Measurement to be made after de-aging at 150°C for 1hr then 24±2hr age at RT 	<ul style="list-style-type: none"> ▪ No major damage ▪ Cap change: <ul style="list-style-type: none"> C0G → within ±7.5% or ±0.75pF whichever is larger. X7R → within ±12.5% ▪ I.R.: ≥500MΩ.
15. High Temperature Load	<ul style="list-style-type: none"> ▪ Test temp.: 125±3°C ▪ Applied voltage: <ol style="list-style-type: none"> 1. (1) ≤100V: 200% rated voltage. 2. (2) 100<V≤500: 150% rated voltage. 3. (3) ≥630V: 120% rated voltage. ▪ Exceptions (X7R Only): <ol style="list-style-type: none"> (1) All parts Cap≥10μF, All parts ≤100V & ≥1μF: 150% rated voltage (2) 2220 ≥100V, ≥15μF: 120% rated voltage (3) 1210 ≥100V, ≥3.3μF: 100% rated voltage ▪ Test time: 1000+24/-0 hrs. ▪ Cap. / DF(Q) / I.R. Measurement to be made after de-aging at 150°C for 1hr then 24±2hr age at RT 	<ul style="list-style-type: none"> ▪ No major damage ▪ Cap change: <ul style="list-style-type: none"> C0G → within ±3.0% or ±0.3pF whichever is larger X7R → within ±12.5% ▪ D.F. value: <ul style="list-style-type: none"> → X7R: dF≤200% of initial requirement ▪ I.R.: ≥1GΩ or RC≥50ΩF, whichever is smaller

Packaging Dimensions & Part Count

Size	1210 & 1812 Single Chip	All Other Sizes
A ₀	Varies	Varies
B ₀	Varies	Varies
K ₀	Varies	Varies
W	16.00±0.30mm	16.00±0.30mm
E	1.75±0.10mm	1.75±0.10mm
F	7.50±0.10mm	7.50±0.10mm
P	8.00±0.10mm	12.00±0.10mm
T	0.40±0.05mm	0.40 or 0.50±0.05mm
P ₀	4.00±0.10mm	
10×P ₀	40.00±0.10mm	
P2	2.00±0.05mm	
D ₀	Ø1.50±0.10/-0.00mm	

Plastic Tape Dimensions

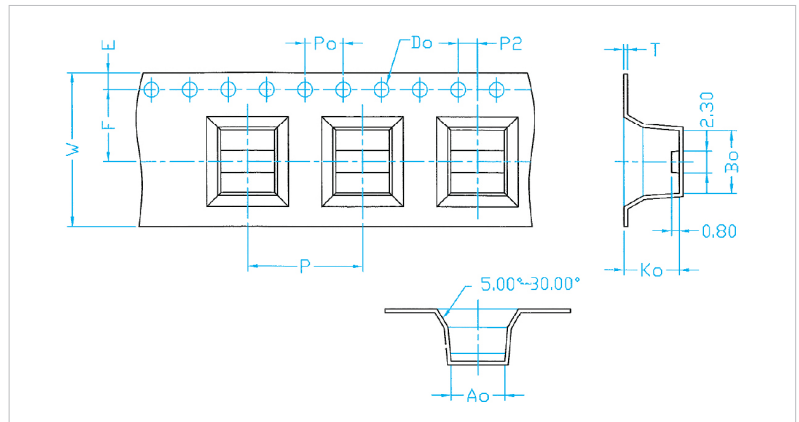

Reel Dimensions 13"

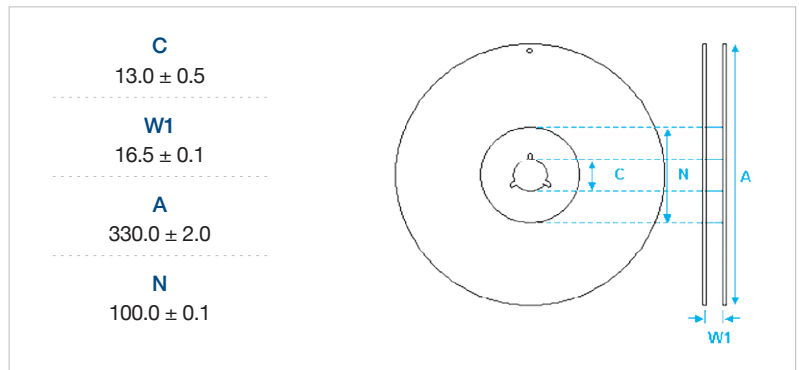

Chip Size	1210	1812	1825	2220	2225
No. Chips	1	1	2	1	2
Parts per 13" Reel	1.5K	1.5K	0.5K	1K	0.5K

Storage & Handling Conditions

- Parts should be stored in their original packing where possible. Temperature should be between 5°C and 40°C. Relative humidity maintained between 20% to 70%
- Do not store in the presence of salts, hydrogen sulfide, sulfur dioxide, chloride gas, ammonia or other acid and alkali.
- It is recommended that the product be used within one year of receipt. Check solderability in case shelf-life extension is needed.
- Parts should be handled with care. If product is dropped it should be discarded even if cracks can not be observed on the exterior of the device.

Soldering Conditions

MegaCap Type (BC Series) are suitable for a range of soldering methods. However, care must be taken not to thermally shock the ceramic chip. Reflow profiles should not exceed 2°C per second in both the heating and cooling stages. The maximum temperature during reflow must not exceed 260°C. It is possible to hand-solder leaded devices. Chips should be pre-heated to within 25°C to 50°C of reflow temperature. Use of a soldering iron rated no more than 30 Watts is recommended. The tip of the soldering iron should be placed on the circuit board landing pad rather than the capacitor lead. At no point should the tip of the soldering iron make contact with the ceramic capacitor body or termination.