

Final Report

Covering the Period 31 May 1972 to 30 September 1973

DIODE BEACON TECHNIQUES

By: ASHOK K. GORWARA

Prepared for:

ROME AIR DEVELOPMENT CENTER
GRIFFISS AIR FORCE BASE
ROME, NEW YORK 13440

CONTRACT F30602-72-C-0444



STANFORD RESEARCH INSTITUTE
Menlo Park, California 94025 · U.S.A.



STANFORD RESEARCH INSTITUTE
Menlo Park, California 94025 · U.S.A.

Final Report

January 1974

Covering the Period 31 May 1972 to 30 September 1973

DIODE BEACON TECHNIQUES

By: ASHOK K. GORWARA

Prepared for:

ROME AIR DEVELOPMENT CENTER
GRIFFISS AIR FORCE BASE
ROME, NEW YORK 13440

CONTRACT F30602-72-C-0444

SRI Project 1970

Approved by:

DON PARKER, *Director*
Electromagnetic Techniques Laboratory

RAY L. LEADABRAND, *Executive Director*
Electronics and Radio Sciences Division

Copy No.

ABSTRACT

In recent years, there has been a great interest in physically small, low-cost, low-energy-consuming electronic markers for tagging materials and vehicles, for air traffic control on the ground, and for surveillance or tracking of personnel over a limited area. The purpose of the study reported here was to investigate the state of the art in low-cost beacon components that will provide a target-like signal for a maximum range of 5 miles in various weather conditions when they are illuminated by search, tracking, or surface-detection radars. Although cooperative beacon transponders are, in general, used for operational functions such as IFF (identification, friend or foe), airborne traffic control, and weapon control and delivery systems, the requirements and frequency of operation for ground-controlled electronic markers are different. In this study, new approaches to providing beacon signals using state-of-the-art devices and circuit techniques were investigated.

The characteristics and specifications of the only three existing types of airport surface detection (ASD) radars, operating at 16.5 GHz (14.3 GHz for latter model), 24 GHz, and 35 GHz, were investigated for use with the three types of target-enhancement techniques — namely, passive reflectors, active reflectors, and cooperative beacon transponders. Target-enhancement requirements were evaluated for these techniques at various ranges up to a maximum of 5 miles for different weather conditions.

General ground clutter and multipath propagation effects on the operation of ASD radars were reviewed briefly and a few procedures were suggested for reduction of the effects.

Performance specifications of the cooperative beacon transponder operating at a range up to 5 miles were determined for the 16.5 GHz, 24 GHz, and 35 GHz frequency bands. General design goals, frequency-independent design techniques, and design concepts were investigated in detail for low-cost, low-energy-consuming and efficient, instantaneous or delay-type cooperative beacon transponders.

A 14.5-GHz solid-state cooperative beacon transponder was designed, fabricated, and tested. Low-cost digital logic techniques were used instead of analog techniques for isolation of receiver and transmitter, and for signal processing. A pulsed, low-Q, coaxial IMPATT diode oscillator was used in the transmitter, and a diode detector was used in the receiver. The power output measured from the IMPATT diode oscillator was 4.8 watts peak, the duty cycle was 0.7%, the pulsewidth was 450 ns, and the dc-to-RF efficiency was 7%. Output power measured from the beacon transponder was 2.4 watts and the minimum detectable signal at the receiver was -42 dBm.

The performance and capability of state-of-the-art active devices were investigated over a wide frequency spectrum. The devices were IMPATT, TRAPATT, Gunn, LSA, p-n junction, point contact, and Schottky-barrier diodes, and bipolar and field-effect transistors.

Different nonoptical and quasi-optical power-combining techniques for oscillators and amplifiers using either direct-generating devices or transistors were investigated for application in medium- or high-power beacon transponders.

Finally, production costs were estimated for small and large quantities of a particular type of beacon transponder operating at 14.5 GHz and 24 GHz.

| | TITLE | PAGE |
|-------|--|--------|
| IV-2 | Calculations of Received Power at the Beacon Transponder for Three ASD Radars at a Distance of Five Miles | IV-5 |
| IV-3 | Commercial Detector Diodes | IV-12 |
| IV-4 | Comparison of AM Transmitters for Beacon Application | IV-16 |
| V-1 | Characteristics of the Cooperative Beacon Transponder | V-30 |
| VI-1 | Peak Power from Hewlett-Packard IMPATT Diodes | VI-2 |
| VI-2 | Performance of Commercial Gunn Diodes | VI-7 |
| VI-3 | Comparison of Receiver Diode Characteristics | VI-11 |
| VI-4 | Efficiency, Power Output, and Gain Capability of Commercially Available Bipolar Transistors | VI-16 |
| VI-5 | Comparison of Noise Figure for State-of-the-Art Bipolar Transistors, Field-Effect Transistors, and Schottky-Barrier Mixer Diodes | VI-20 |
| VII-1 | Summary of Power-Combining Techniques for High-Power Beacon-Transponder Application | VII-12 |
| VII-2 | Practical Combiner Techniques for Beacon Transponder | VII-15 |
| VII-3 | Review of Solid-State Devices for High-Power Combiners Used in Beacon Transponders | VII-16 |
| C-1 | Characteristics of Texas Instruments ASD Radar at LAX | C-1 |

| SECTION | PAGE |
|---|-------|
| IV COOPERATIVE-BEACON-TRANSPONDER DESIGNS AND CONCEPTS | IV-1 |
| A. GENERAL | IV-1 |
| B. BEACON-TRANSPONDER SPECIFICATION FOR THREE ASD RADARS | IV-1 |
| 1. Antenna Specifications | IV-1 |
| 2. Transmitter Specifications | IV-1 |
| 3. Receiver Specifications | IV-2 |
| C. BEACON-TRANSPONDER DESIGN GOALS | IV-3 |
| D. GENERAL TRANSPONDER TECHNIQUES | IV-5 |
| 1. Common Antenna System | IV-7 |
| 2. Size | IV-7 |
| 3. Efficiency | IV-7 |
| 4. Utilization of Power Supplies when Transponder is Illuminated by ASD Radar | IV-8 |
| E. BEACON-TRANSPONDER CONCEPTS | IV-8 |
| 1. Receiver Concepts | IV-8 |
| 2. Diode Detector | IV-10 |
| 3. Mixer Concepts | IV-12 |
| a. Single-Ended Mixer | IV-13 |
| b. Single-Balanced Mixer | IV-13 |
| c. Double-Balanced Mixer | IV-13 |
| d. Image-Reject Mixer | IV-14 |
| 4. Transmitter Concepts | IV-14 |
| F. CONCLUSIONS | IV-17 |
| 1. Recommendations Concerning the Type of Mixer Receiver for Low-Cost Beacon Transponder | IV-17 |
| 2. Recommendations Concerning the Type of Transmitter Concept for Low-Cost Beacon Transponder | IV-17 |
| REFERENCES | IV-19 |
| V KU-BAND COOPERATIVE-BEACON-TRANSPONDER DEVELOPMENT | V-1 |
| A. GENERAL | V-1 |
| B. CONCEPTUAL DESIGN | V-1 |
| C. DETAILED DESIGN | V-4 |
| 1. IMPATT Diode Oscillator | V-4 |
| a. General | V-4 |
| b. Equivalent Circuit of IMPATT Diode Chip | V-4 |
| c. Packaged Diode Equivalent Circuit | V-5 |
| d. Selection of IMPATT Diode | V-5 |
| e. Low-Q Coaxial Fixed-Tuned IMPATT Diode Oscillator | V-6 |

| | TITLE | PAGE |
|--------|---|--------|
| V-22 | IMPATT Diode Oscillator Current and Voltage Response | V-28 |
| V-23 | Logic-Pulse-Train Waveforms at Input and Output of Signal-Processing System | V-28 |
| VI-1 | Performance of IMPATT Diodes -- 1973 | VI-3 |
| VI-2 | Performance of TRAPATT Diodes -- 1973 | VI-5 |
| VI-3 | Performances of Gunn Diodes -- 1973 | VI-6 |
| VI-4 | Performance of LSA Diodes -- 1973 | VI-10 |
| VI-5 | Noise-Figure Performance of Commercial Schottky Barrier Mixer Diodes -- 1973 | VI-12 |
| VI-6 | Noise-Figure Performance of Commercial Point Contact Mixer Diodes -- 1973 | VI-14 |
| VI-7 | Tangential Sensitivity Performance of Commercial Silicon Schottky Barrier Detector Diodes -- 1973 | VI-15 |
| VI-8 | Noise-Figure Performance of Commercial Bipolar Transistors -- 1973 | VI-16 |
| VI-9 | Power as a Function of Frequency of Commercial Microwave Transistors -- 1973 | VI-17 |
| VI-10 | Noise-Figure Performance of FET Devices -- 1973 | VI-19 |
| VII-1 | A Series-Parallel Array of Eight Diodes Each with Self-Biasing Resistors and Coupled Line Filters at the Input and Output Frequencies | VII-2 |
| VII-2 | Cascaded Transmission Amplifiers | VII-4 |
| VII-3 | Cascaded Transmission Oscillators | VII-4 |
| VII-4 | Power-Combiner Scheme for Amplifiers Using Hybrids | VII-5 |
| VII-5 | Power-Combiner Scheme for Oscillators Using Hybrids | VII-5 |
| VII-6 | Maximum Number of Power-Combining Stages for Various Combiner Losses and Required Combiner Efficiency. Source: Ref. 1. | VII-6 |
| VII-7 | Maximum Number of Combiner Stages for a Required System Efficiency of 25 Percent. Source: Ref. 1. | VII-7 |
| VII-8 | Iterative Power-Combiner Scheme for Amplifiers and Oscillators | VII-8 |
| VII-9 | Closed-Volume Phased-Array Combiner | VII-9 |
| VII-10 | Radial-Cavity Combiner | VII-10 |
| VII-11 | Elliptical-Cavity Combiner | VII-11 |
| VII-12 | Low-Power Beacon Transponder | VII-14 |
| VII-13 | Medium-Power Beacon Transponder | VII-14 |
| VII-14 | High-Power Beacon Transponder | VII-14 |
| VIII-1 | Proposed Conceptual Block Diagram of High-Sensitivity Cooperative Beacon Transponder Used in Production Quantities | VIII-2 |

| SECTION | PAGE |
|--|---------------|
| E. CONCLUSIONS | VI-19 |
| 1. Comparison of Noise Figure of Low-Noise Devices | VI-19 |
| 2. Forecasts on Capabilities of Solid-State Devices | VI-20 |
| REFERENCES | VI-22 |
| VII POWER-COMBINING TECHNIQUES | VII-1 |
| A. GENERAL | VII-1 |
| B. NONOPTICAL COMBINING TECHNIQUES | VII-1 |
| 1. Cascaded Transmission Amplifiers and Oscillators | VII-3 |
| 2. Weakly Coupled Combining Circuit | VII-5 |
| 3. Strongly Coupled Combining Circuit | VII-7 |
| C. QUASI-OPTICAL COMBINING TECHNIQUES | VII-8 |
| D. CONCLUSIONS | VII-9 |
| REFERENCES | VII-17 |
| VIII PRODUCTION COSTS OF COOPERATIVE BEACON TRANSPONDER | VIII-1 |
| A. GENERAL | VIII-1 |
| B. SMALL-QUANTITY PRODUCTION COST BUDGET | VIII-3 |
| 1. Ku-Band Beacon-Transponder Scheme Using a Detector Front End | VIII-3 |
| 2. Ku-Band Beacon-Transponder Scheme Using a Mixer Front End | VIII-4 |
| C. LARGE-QUANTITY PRODUCTION-COST BUDGET ESTIMATES | VIII-4 |
| 1. Ku-Band Beacon-Transponder Scheme Using a Detector Front End | VIII-4 |
| 2. Ku-Band Beacon-Transponder Scheme Using a Mixer Front End | VIII-5 |
| D. CONCLUSIONS | VIII-5 |
| IX RECOMMENDATIONS FOR FUTURE STUDIES AND DEVELOPMENTS | IX-1 |
| X FINAL CONCLUSIONS | IX-1 |
| APPENDICES | |
| A NEEDS FOR BETTER DETECTION TECHNIQUES AND AIR TRAFFIC CONTROL ON THE GROUND | A-1 |
| B AIRBORNE BEACON TRANSPONDER | B-1 |
| C CHARACTERISTICS OF TEXAS INSTRUMENTS ASD RADAR | C-1 |

DD1473 FORM

| SECTION | PAGE |
|--|---------------|
| E. CONCLUSIONS | VI-19 |
| 1. Comparison of Noise Figure of Low-Noise Devices | VI-19 |
| 2. Forecasts on Capabilities of Solid-State Devices | VI-20 |
| REFERENCES | VI-22 |
| VII POWER-COMBINING TECHNIQUES | VII-1 |
| A. GENERAL | VII-1 |
| B. NONOPTICAL COMBINING TECHNIQUES | VII-1 |
| 1. Cascaded Transmission Amplifiers and Oscillators | VII-3 |
| 2. Weakly Coupled Combining Circuit | VII-5 |
| 3. Strongly Coupled Combining Circuit | VII-7 |
| C. QUASI-OPTICAL COMBINING TECHNIQUES | VII-8 |
| D. CONCLUSIONS | VII-9 |
| REFERENCES | VII-17 |
| VIII PRODUCTION COSTS OF COOPERATIVE BEACON TRANSPONDER | VIII-1 |
| A. GENERAL | VIII-1 |
| B. SMALL-QUANTITY PRODUCTION COST BUDGET | VIII-3 |
| 1. Ku-Band Beacon-Transponder Scheme Using a Detector Front End | VIII-3 |
| 2. Ku-Band Beacon-Transponder Scheme Using a Mixer Front End | VIII-4 |
| C. LARGE-QUANTITY PRODUCTION-COST BUDGET ESTIMATES | VIII-4 |
| 1. Ku-Band Beacon-Transponder Scheme Using a Detector Front End | VIII-4 |
| 2. Ku-Band Beacon-Transponder Scheme Using a Mixer Front End | VIII-5 |
| D. CONCLUSIONS | VIII-5 |
| IX RECOMMENDATIONS FOR FUTURE STUDIES AND DEVELOPMENTS | IX-1 |
| X FINAL CONCLUSIONS | IX-1 |
| APPENDICES | |
| A. NEEDS FOR BETTER DETECTION TECHNIQUES AND AIR TRAFFIC CONTROL ON THE GROUND | A-1 |
| B. AIRBORNE BEACON TRANSPONDER | B-1 |
| C. CHARACTERISTICS OF TEXAS INSTRUMENTS ASD RADAR | C-1 |

DD1473 FORM

| | TITLE | PAGE |
|--------|---|--------|
| V-22 | IMPATT Diode Oscillator Current and Voltage Response | V-28 |
| V-23 | Logic-Pulse-Train Waveforms at Input and Output of Signal-Processing System | V-28 |
| VI-1 | Performance of IMPATT Diodes -- 1973 | VI-3 |
| VI-2 | Performance of TRAPATT Diodes -- 1973 | VI-5 |
| VI-3 | Performances of Gunn Diodes -- 1973 | VI-6 |
| VI-4 | Performance of LSA Diodes -- 1973 | VI-10 |
| VI-5 | Noise-Figure Performance of Commercial Schottky Barrier Mixer Diodes -- 1973 | VI-12 |
| VI-6 | Noise-Figure Performance of Commercial Point Contact Mixer Diodes -- 1973 | VI-14 |
| VI-7 | Tangential Sensitivity Performance of Commercial Silicon Schottky Barrier Detector Diodes -- 1973 | VI-15 |
| VI-8 | Noise-Figure Performance of Commercial Bipolar Transistors -- 1973 | VI-16 |
| VI-9 | Power as a Function of Frequency of Commercial Microwave Transistors -- 1973 | VI-17 |
| VI-10 | Noise-Figure Performance of FET Devices -- 1973 | VI-19 |
| VII-1 | A Series-Parallel Array of Eight Diodes Each with Self-Biasing Resistors and Coupled Line Filters at the Input and Output Frequencies | VII-2 |
| VII-2 | Cascaded Transmission Amplifiers | VII-4 |
| VII-3 | Cascaded Transmission Oscillators | VII-4 |
| VII-4 | Power-Combiner Scheme for Amplifiers Using Hybrids | VII-5 |
| VII-5 | Power-Combiner Scheme for Oscillators Using Hybrids | VII-5 |
| VII-6 | Maximum Number of Power-Combining Stages for Various Combiner Losses and Required Combiner Efficiency. Source: Ref. 1. | VII-6 |
| VII-7 | Maximum Number of Combiner Stages for a Required System Efficiency of 25 Percent. Source: Ref. 1. | VII-7 |
| VII-8 | Iterative Power-Combiner Scheme for Amplifiers and Oscillators | VII-8 |
| VII-9 | Closed-Volume Phased-Array Combiner | VII-9 |
| VII-10 | Radial-Cavity Combiner | VII-10 |
| VII-11 | Elliptical-Cavity Combiner | VII-11 |
| VII-12 | Low-Power Beacon Transponder | VII-14 |
| VII-13 | Medium-Power Beacon Transponder | VII-14 |
| VII-14 | High-Power Beacon Transponder | VII-14 |
| VIII-1 | Proposed Conceptual Block Diagram of High-Sensitivity Cooperative Beacon Transponder Used in Production Quantities | VIII-2 |

| SECTION | PAGE |
|---|-------|
| IV COOPERATIVE-BEACON-TRANSPONDER DESIGNS AND CONCEPTS | IV-1 |
| A. GENERAL | IV-1 |
| B. BEACON-TRANSPONDER SPECIFICATION FOR THREE ASD RADARS | IV-1 |
| 1. Antenna Specifications | IV-1 |
| 2. Transmitter Specifications | IV-1 |
| 3. Receiver Specifications | IV-2 |
| C. BEACON-TRANSPONDER DESIGN GOALS | IV-3 |
| D. GENERAL TRANSPONDER TECHNIQUES | IV-5 |
| 1. Common Antenna System | IV-7 |
| 2. Size | IV-7 |
| 3. Efficiency | IV-7 |
| 4. Utilization of Power Supplies when Transponder is Illuminated by ASD Radar | IV-8 |
| E. BEACON-TRANSPONDER CONCEPTS | IV-8 |
| 1. Receiver Concepts | IV-8 |
| 2. Diode Detector | IV-10 |
| 3. Mixer Concepts | IV-12 |
| a. Single-Ended Mixer | IV-13 |
| b. Single-Balanced Mixer | IV-13 |
| c. Double-Balanced Mixer | IV-13 |
| d. Image-Reject Mixer | IV-14 |
| 4. Transmitter Concepts | IV-14 |
| F. CONCLUSIONS | IV-17 |
| 1. Recommendations Concerning the Type of Mixer Receiver for Low-Cost Beacon Transponder | IV-17 |
| 2. Recommendations Concerning the Type of Transmitter Concept for Low-Cost Beacon Transponder | IV-17 |
| REFERENCES | IV-19 |
| V KU-BAND COOPERATIVE-BEACON-TRANSPONDER DEVELOPMENT | V-1 |
| A. GENERAL | V-1 |
| B. CONCEPTUAL DESIGN | V-1 |
| C. DETAILED DESIGN | V-4 |
| 1. IMPATT Diode Oscillator | V-4 |
| a. General | V-4 |
| b. Equivalent Circuit of IMPATT Diode Chip | V-4 |
| c. Packaged Diode Equivalent Circuit | V-5 |
| d. Selection of IMPATT Diode | V-5 |
| e. Low-Q Coaxial Fixed-Tuned IMPATT Diode Oscillator | V-6 |

| | TITLE | PAGE |
|-------|--|--------|
| IV-2 | Calculations of Received Power at the Beacon Transponder for Three ASD Radars at a Distance of Five Miles | IV-5 |
| IV-3 | Commercial Detector Diodes | IV-12 |
| IV-4 | Comparison of AM Transmitters for Beacon Application | IV-16 |
| V-1 | Characteristics of the Cooperative Beacon Transponder | V-30 |
| VI-1 | Peak Power from Hewlett-Packard IMPATT Diodes | VI-2 |
| VI-2 | Performance of Commercial Gunn Diodes | VI-7 |
| VI-3 | Comparison of Receiver Diode Characteristics | VI-11 |
| VI-4 | Efficiency, Power Output, and Gain Capability of Commercially Available Bipolar Transistors | VI-16 |
| VI-5 | Comparison of Noise Figure for State-of-the-Art Bipolar Transistors, Field-Effect Transistors, and Schottky-Barrier Mixer Diodes | VI-20 |
| VII-1 | Summary of Power-Combining Techniques for High-Power Beacon-Transponder Application | VII-12 |
| VII-2 | Practical Combiner Techniques for Beacon Transponder | VII-15 |
| VII-3 | Review of Solid-State Devices for High-Power Combiners Used in Beacon Transponders | VII-16 |
| C-1 | Characteristics of Texas Instruments ASD Radar at LAX | C-1 |

ACKNOWLEDGMENT

The author wishes to acknowledge the valuable suggestions and contributions from other SRI staff members. Don Parker was project supervisor, and Bill Weir performed calculations of the target-enhancement requirements for the existing ASD radars and investigated clutter and multipath propagation effects.

Valuable directions in steering the research program toward the more immediately useful objectives were received from RADC monitor, Mr. Ralph Arenz.

The cooperation of the staff of Hewlett-Packard Associates, Palo Alto, California, is also hereby acknowledged. Allen Podel, George Pfund, and Bert Berson were especially helpful in the selection of high power pulsed IMPATT diodes and fast switching current modulators.

I. INTRODUCTION

A. PURPOSE OF CONTRACT

The purpose of this contract was to investigate state-of-the-art solid-state microwave devices (single or in arrays) and circuits in beacon components or transponders that will provide a target-like signal when they are illuminated by search, tracking, or surface-detection radars in the following frequency bands: D (1-2 GHz), E (2-3 GHz), G (4-6 GHz), I (8-10 GHz), J (10-20 GHz), and K (20-40 GHz). A major objective of this program was to show the feasibility of a new class of beacon components that lend themselves to use in physically small, low-cost, low-energy-consuming electronic markers. Some important applications of the electronic markers are electronic tagging of material and vehicles, air traffic control, and surveillance or tracking of personnel over a limited area. Interest in this investigation was generated primarily by the need to detect aircraft and vehicles on the ground over a maximum range of 5 miles in an airport environment for all weather conditions. Further details on the needs for air traffic control on the ground are discussed in Appendix A.

In order to satisfy the above main objective of this program, other program sub-tasks and goals were defined as follows:

- Task 1 – Review specifications and characteristics of all the existing airport surface detection (ASD) radars and tracking radars at D, E, G, I, J, and K frequency bands that could be used with various passive or active enhancement devices.
- Task 2 – Evaluate target-enhancement requirements for existing ASD radars or tracking radars using active reflectors, passive reflectors, and beacon components as target enhancement devices, for detection at ranges up to a maximum of 5 miles. Also study target-enhancement devices and the possible tradeoffs among the characteristics of these devices, for various ranges, taking into consideration the ASD radar operating frequency and antenna gain (receiver and transmitter), the type of receiver, the required system signal-to-noise ratio (SNR), the propagation losses due to weather, and various other system losses.
- Task 3 – Investigate briefly the multipath and clutter effects on the operation of ASD or tracking radars. Results of this investigation will show which enhancement technique or system to use for reduced multipath or clutter effects.
- Task 4 – Review and perform studies of various beacon transponder designs and concepts that could be used for low-cost, small-sized, and efficient target enhancers for a maximum range of 5 miles. Perform studies of tradeoffs among these designs and concepts. Performance specifications and requirements for the beacon transponders will be defined by the studies performed in Tasks 1, 2, and 3.

- Task 5 – Review the state of the art in solid-state microwave devices that could be used in beacon components. The devices considered included the following:
 - IMPATT diodes
 - TRAPATT diodes
 - Gunn diodes
 - LSA diodes
 - Schottky-barrier diodes
 - Point-contact diodes
 - Bipolar transistors
 - Field-effect transistors.
- Task 6 – Review potential methods of microwave power generation using nonoptical and quasi-optical combining techniques. Such techniques could be used in high-power beacon components.
- Task 7 – Fabricate solid-state beacon-transponder breadboard that could be used for target-enhancement purposes in conjunction with an existing ASD or tracking radar. The main objectives of this breadboard model are to demonstrate the key functions and capabilities of a low-cost, low-energy-consuming cooperative beacon enhancer. Designs of the breadboard beacon transponder will result from the theoretical studies performed in Tasks 4, 5, and 6.
- Task 8 – Estimate the production costs of the beacon components or transponders that could be used for target-enhancement purposes. It was also required that the power sources be self-contained and that provisions be made to permit operation of the diode beacon from an external source of standard voltage – i.e., 6 V, 12 V, 28 V, or 115 Vac.

B. BACKGROUND

Cooperative beacon transponders are in general used for operational functions such as IFF (identification friend or foe), air traffic control (airborne)*, and weapon control and delivery systems. These beacons are usually high-power, long-range equipment and vary in cost from several hundred to several thousand dollars. Although attempts have been made to scale such components down in size and power, the resulting reductions in power consumption (battery requirements) and cost have not been significant. Earlier studies in this area have evaluated designs such as simple antenna elements terminated with controlled switches or diodes, active signal repeaters using TWTs, and passive reflectors such as corner reflectors and Luneberg lenses. These designs did not lend themselves for use as low-cost enhancers. Thus, there is a need to investigate new approaches to providing beacon signals using state-of-the-art devices and circuit techniques.

C. ORGANIZATION OF REPORT

This report is organized in ten sections, including the Introduction (Section I), Recommendations for Future Studies and Developments (Section IX), and Final Conclusions (Section X). At the end of the report, three appendices are included that contain additional information. The above-mentioned sections report independently and conclusively the investigations on all the program tasks outlined earlier in this section. References are listed at the end of each major section.

*Refer to Appendix B for details of a typical airborne beacon transponder presently used by commercial airlines.

The following is a brief description of the contents of the major sections:

- Section II
 - Review of all existing airport surface detection or tracking ASD radars that could be used for target-enhancement applications. Discussion of the characteristics and specifications of the three ASD radars, operating at 16.5 GHz (14.3 GHz later model), 24 GHz, and 35 GHz, that were investigated and analyzed.
 - Review of the three target-enhancement techniques — namely, passive reflectors (corner reflector or Van Atta arrays), active reflectors (active retro-directive arrays), and cooperative beacon transponders.
 - Evaluation of target-enhancement requirements for the above three target-enhancement techniques using existing ASD radars at 16.5 GHz, 24 GHz, and 35 GHz. Calculations for these target-enhancement requirements are performed at various ranges up to a maximum of 5 miles for different weather conditions.
 - Recommendations and specifications on the type of enhancement technique to use for a maximum range of 5 miles. These recommendations are based on the utilization of the above-mentioned ASD radars.
- Section III
 - A brief review and discussion of ground-clutter and multipath-propagation effects that could affect the operation of ASD or tracking radars for clear detection.
 - A solution to reduce the ground-clutter effects by the use of frequency-discrimination techniques as applied in the design of beacon transponders.
 - A solution to reduce the ground-clutter effects and multipath effects by the use of multiple ASD or tracking radar systems at a given location.
- Section IV
 - Performance specifications for cooperative beacon transponders at 16.5 GHz, 24 GHz, and 35 GHz frequency bands that could be used as target-enhancement devices in conjunction with existing ASD radars for a maximum range of 5 miles.
 - General design goals, design techniques, and design concepts for low-cost, low-energy-consuming and efficient cooperative beacon transponders independent of the frequency of operations.
 - Information on the design of instantaneous and delay types of beacon transponder.
 - Recommendations on the type of receiver concept and transmitter concept to use in a beacon-transponder design for low-cost fabrication and efficient operation.
- Section V
 - Details of the development, electrical and mechanical designs, fabrication, integration, and testing of an all-solid-state 14.5-GHz cooperative beacon transponder that could be used for target-enhancement purposes for a range of 5 miles in conjunction with an existing 4.5-dB NF ASD (T.I.) radar.
 - Details of the electrical and mechanical designs, and the fabrication and testing of a high-power, pulsed, low-Q coaxial IMPATT diode oscillator. Also included are details concerning the selection of the double-drift IMPATT diodes and the design of the matching network.

- Details of the design and fabrication of the diode detector receiver used in the above beacon transponder.
 - Details of the design, fabrication, and testing of the signal-processing system used for the isolation of the receiver from the transmitter and as a memory logic system.
 - Details of the design, fabrication, and testing of the current modulator used in driving the IMPATT diode oscillator.
 - Operational test results and data obtained in the laboratory on the fabricated 14.5-GHz cooperative-beacon-transponder breadboard that shows the feasibility and highlights of a low-cost, all solid-state transponder.
- Section VI
 - Recent information regarding the performance and capability of the state-of-the-art active devices (direct-generating diodes, receiver diodes, and transistors) that could be used in the transmitter or the receiver of the beacon transponders at various frequency bands (D, E, G, I, J and K).
 - Discussion of the selection of active devices for optimum and efficient performance at low cost and for applications in practical beacon transponders.
- Section VII
 - Reviews and discussions of various RF power-combining techniques for oscillators and amplifiers at D, E, G, I, J, and K frequency bands. Two types of power-combining techniques are reviewed – namely, nonoptical techniques and quasi-optical techniques.
 - Design information on various RF power combining techniques using either direct-generating devices or transistors.
 - Appraisal and status of the state-of-the-art solid-state transmitting devices that could be used in various high-power combining circuits. Recommendations on RF power-combining schemes suitable for medium- and high-power beacon transponders at D, E, G, I, J, and K frequency bands.
- Section VIII
 - Estimates on the small- and large-quantity production costs of 14.5-GHz cooperative beacon transponders (flight hardware) similar to the type developed and fabricated as described in Section V. A simple diode detector is used in the receiver.
 - Estimates on the small- and large-quantity production costs of 14.5-GHz cooperative beacon transponders (flight hardware) using a mixer pumped with a local oscillator as a receiver.
 - Recommendations for reducing the production costs of beacon transponders, and cost estimates for the production of 24-GHz beacon transponders.

II. EVALUATION OF AIRPORT SURFACE DETECTION (ASD) RADARS AND TARGET-ENHANCEMENT REQUIREMENTS

A. GENERAL

Under the terms of this contract, it was required to calculate and analyze signal-level requirements for target-enhancement devices using active reflectors, passive reflectors, or beacon components when illuminated by search, tracking, or surface-detection radars in the D, E, G, I, J and K frequency bands. The overall system specifications were set to achieve target enhancement for a maximum range of 5 miles. In order to evaluate the target-enhancement requirements for the various types of enhancement techniques, knowledge of the search, tracking, or surface-detection radars was necessary.

A review of existing radars indicated that only three airport surface-detection (ASD) radars were applicable to this study. The main applications for the ASD radars are for tracking vehicles and airplanes on the ground in an airport environment. These radars operate at the J- and K-bands, and return pulses from all targets are displayed on a scope for visual identification. The accuracy and resolution of these radars depend on the radar transmitter and receiver characteristics, propagation losses due to weather, frequency of operation, and target range and size. As the frequency of operation is increased, target resolution increases, but propagational losses due to weather also increase considerably, thereby limiting the range coverage.

The ASD radars are useful for identifying large objects (e.g., airplanes), but are limited in range performance for small airplanes and vehicles. The objective of the study described in this section was to extend the range of identification of these ASD radars by the utilization of enhancement devices, without much modification to the radar design. The concepts developed for the ASD radars are applicable or can be readily adapted to radar systems at other frequencies.

B. AIRPORT SURFACE DETECTION RADARS

There are presently three types of ASD radars. These are ASD (Texas Instruments) at 16.5 GHz, ASDE II (Airborne Instrument Labs) at 24 GHz, and ASMI (Decca Radar) at 35 GHz.^{1*} The system characteristics of these typical ASD radars are summarized in Table II-1 and the attenuation and backscatter coefficients for various weather conditions are summarized in Table II-2. These radar and propagation parameters were used as being typical for each frequency band.

The FCC has allocated the frequency bands 14-14.3 GHz, 24.25-25.25 GHz, and 31.8-33.4 GHz for air traffic control and surface detection in the future. Although our target-enhancement studies, discussed later, were performed at 16.5 GHz, 24 GHz, and 35 GHz (which are close to the frequencies specified by the FCC for air traffic control) the results and conclusions are still valid and applicable for the objectives of this contract. The resulting data on target enhancement can be used for purposes of comparison to determine the performance of the radars when target-enhancement devices are used.

*References are listed at the end of each major section in which references are cited.

Table II-1. Airport Surface Detection System Parameters

| Parameter | Texas Instruments ASD Radar | ASDE-II (AIL) | ASMI MK5 (DECCA) |
|---|--------------------------------|--|--|
| Antenna Gain | 33 dB | 45 dB | 42.5 dB |
| Azimuth Beamwidth | 0.33° | 0.25° | 0.4° |
| Elevation Beamwidth | ≅ 15° | 1° to 3 dB 1° to 25° csc ² | 3° to 3 dB 3° to 14° csc ² |
| Peak Power | 30 KW | 36 KW | 12 KW |
| Pulsewidth | 40 ns | 20 ns | 30 ns |
| Pulse Rate | 15 kHz | 14.4 kHz | 15 kHz |
| Frequency | 16.5 to 17 GHz | 24 GHz | 35 GHz |
| IF Bandwidth | 35 MHz | 100 MHz | 60 MHz |
| Clutter Reduction with CP All Weather Conditions Except Snow | 17 dB | 17 dB | 17 dB |
| Snow | 13 dB | 13 dB | 13 dB |
| Target Loss with CP | 4 dB | 4 dB | 4 dB |
| Losses (including radome) | 8 dB | 8 dB | 8 dB |
| Noise Figure | 11 dB | 17 dB | 16 dB |
| Pulses Integrated | 6 | 10 | 1 |
| Integration Gain | 5 dB* | 5 dB† | 0 dB |

*Video Integrator with fixed-threshold decision device.

†PPI with human operator.

Table II-2. Attenuation and Backscatter Coefficients for Various Weather Conditions

| Weather Type | ASD (TI) 16.5 GHz | | ASDE II (AIL) 24 GHz | | ASMI MK5 (Decca) 35 GHz | |
|----------------------|------------------------------------|--|------------------------------------|--|------------------------------------|--|
| | Two-Way Attenuation (dB/nmi) | Backscatter Coefficient (dB m ² /m ³) | Two-Way Attenuation (dB/nmi) | Backscatter Coefficient (dB m ² /m ³) | Two-Way Attenuation (dB/nmi) | Backscatter Coefficient (dB m ² /m ³) |
| Clear | 0.08 | — | 0.4 | — | 0.25 | — |
| Rain 1 mm/hr | 0.31 | -61.5 | 0.6 | -54.0 | 1.5 | -47.0 |
| Rain 4 mm/hr | 1.20 | -52.0 | 2.4 | -46.0 | 6.0 | -39.0 |
| Rain 16 mm/hr | 4.8 | -43.0 | 9.6 | -36.0 | 24.0 | -32.0 |
| Dry Snow 4 mm/hr* | 0.15 | -59.2 | 0.74 | -53.0 | 0.46 | -46.0 |
| Wet Snow 4 mm/hr* | 0.15 | -46.8 | 0.74 | -40.6 | 0.46 | -30.6 |
| Fog 100 ft | 2.38 | -89.5 | 5.05 | -82.0 | 7.4 | -75.0 |

*Equivalent water content (melted).

C. TARGET-ENHANCEMENT TECHNIQUES

There are basically three categories of enhancement techniques that we considered in this study.

They are:

- Passive reflector
 - Corner reflector
 - Van Atta array
- Active reflector
 - Active retrodirective array
- Cooperative beacon transponder.

Passive and active reflectors offer target enhancement at the same frequency as the surface-detection or tracking radar. In the case of beacon transponders, outgoing signals can be at different frequencies or at the same frequency as the incoming signals from the radar. The beacon transponder operating at a different frequency than the radar offers a performance advantage for target enhancement because the background clutter due to stationary objects or ground can be ignored at the radar receiver.

D. TARGET-ENHANCEMENT REQUIREMENTS

Radar range equations were applied to the three radars in Table II-1 to determine the requirements for target enhancement using passive reflectors, active reflectors, and beacon transponders.* The radar range equations are as follows:

- Radar Cross Section of Passive Reflectors

$$\sigma = \left[\frac{(4\pi)^3 R^4 (kT_i B) 10^{\alpha R} L_s L_t}{P_t G_t^2 \lambda^2 G_i} + \frac{L_t}{L_c} \sigma_c \right] \cdot \text{SNR} \quad (II-1)$$

$$kT_i B = kT_o B \overline{NF} \quad (II-2)$$

$$\sigma_c = v_m \sigma_c^o \quad (II-3)$$

$$v_m = \frac{\pi R^2 \tau \theta_B \phi_B}{8} \quad (II-4)$$

Assumption: Clutter and receiver noise are additive.

* Performance specifications of a T.I radar at 14.3 GHz are given in Appendix C. These were not available at the time of the study.

- Gain of Active Reflectors

$$G = G_a \sqrt{G_d} = \sqrt{\frac{\pi}{\lambda^2} \sigma} \quad (11-5)$$

Assumption: Clutter and receiver noise are additive.

- Transponder Effective Radiated Power

$$P_p G_p = \frac{(4\pi R)^2 (kT_i B) L_s L_t (10)^{\frac{1}{2}\alpha R}}{2G_t G_i \lambda^2} \cdot \text{SNR} \quad (11-6)$$

Assumptions: Transponder antenna linearly polarized.

Transponder frequency different from radar transmitter.

Forward scatter by clutter is negligible.

Definition of the parameters are as follows:

- P_t = Transmitter peak power
- P_p = Transponder peak power
- G_t = Transmitter antenna gain
- G_p = Transponder antenna gain
- G_a = Active-reflector antenna gain
- G_i = Pulse-integration gain
- θ_B = Azimuth 3-dB beamwidth (transmitter antenna)
- φ_B = Elevation 3-dB beamwidth (transmitter antenna)
- λ = Wavelength
- τ = Pulsewidth
- B = Noise (\sim IF) bandwidth
- \overline{NF} = Receiver noise figure
- L_s = System loss (two-way)
- L_t = Signal reduction (due to CP)
- L_c = Clutter reduction (due to CP)
- α = Clutter attenuation (two-way)
- T_i = Effective noise temperature
- T_o = Standard noise temperature (290°K)
- k = Boltzmann's constant ($1.38 \times 10^{-23} \text{ J/}^\circ\text{K}$)
- σ_c^o = Clutter backscatter coefficient
- v_m = Effective clutter volume
- N_c = Clutter noise
- σ = Target radar cross section

- R = Range
- c = Velocity of light (3×10^8 m/s)
- SNR = Signal-to-noise ratio
- P_d = Probability of detection
- P_{fa} = False-alarm probability

Equations (II-1), (II-5), and (II-6) were applied to the three listed ASD radars to determine the requirements for target enhancement for the control of aircraft vehicles, and personnel on the ground under various environmental conditions. Data are tabulated in Tables II-3 through II-14. All of these tables were generated for a probability of detection of 0.95 and a probability of false alarm of 10^{-6} . This corresponds to a minimum SNR ratio for a nonfluctuating target of 13.8 dB. All the tabulations are in statute miles in order that the data be consistent with the existing literature we have on ASD radars.

Table II-3. Transponder Power-Gain Product (PXG) Required to Produce an SNR of 13.8 dB in ASD (T.I.) Radar Receiver with 11-dB Noise Figure (Frequency -- 16.5 GHz)

| Atmospheric Conditions | Power-Gain Product, PXG (dBW) | | | | |
|---------------------------|-------------------------------|---------------|-----------------|---------------|-------------------|
| | 1 Mile Range | 2 Miles Range | 3 Miles Range | 4 Miles Range | 5 Miles Range |
| Clear | -12.7 (0.054 W) | -6.7 | -3.1 | -0.6 | 1.5 (1.4 W) |
| Rain 1 mm/hr | -12.6 | -6.5 | -2.8 | -0.2 | 2.0 |
| Rain 4 mm/hr | -12.3 | -5.7 | -1.7 | 1.4 | 3.9 |
| Rain 16 mm/hr | -10.7 (0.085 W) | -2.6 | 3.1 (2.04 W) | 7.7 | 11.7 (14.79 W) |
| Snow, Dry 4 mm/hr | -12.7 | -6.6 | -3.0 | -0.5 | 1.6 |
| Snow, Wet 4 mm/hr | -12.7 | -6.6 | -3.0 | -0.5 | 1.6 |
| Fog, 100-ft Visibility | -11.8 | -4.7 | -0.1 | 3.5 | 6.5 |

Table II-4. Transponder Power-Gain Product (PXG) Required to Produce an SNR of 13.8 dB in ASD (T.I.) Radar Receiver with 4.5-dB Noise Figure (Frequency -- 16.5 GHz)

| Atmospheric Conditions | Power-Gain Product, PXG (dBW) | | | | |
|---------------------------|-------------------------------|---------------|--------------------|---------------|-------------------|
| | 1 Mile Range | 2 Miles Range | 3 Miles Range | 4 Miles Range | 5 Miles Range |
| Clear | -19.2 (12.0 mW) | -13.2 | -9.6 (0.1096 W) | -7.1 | -5.1 (0.309 W) |
| Rain 1 mm/hr | -19.1 | -13.0 | -9.3 | -6.7 | -4.6 |
| Rain 4 mm/hr | -18.8 | -12.2 | -8.2 | -5.2 | -2.7 |
| Rain 16 mm/hr | -17.2 (19.05 mW) | - 9.1 | -3.5 (0.4467 W) | 1.2 | 5.2 (3.31 W) |
| Snow, Dry 4 mm/hr | -19.2 | -13.1 | -9.5 | -7.0 | -5.0 |
| Snow, Wet 4 mm/hr | -19.2 | -13.1 | -9.5 | -7.0 | -5.0 |
| Fog, 100 ft Visibility | -18.3 | -11.2 | -6.6 | -3.1 | -0.1 |

Table II-5. Transponder Power-Gain Product (PXG) Required to Produce an SNR of 13.8 dB in ASDE II (AIL) Radar Receiver with 17-dB Noise Figure (Frequency -- 24 GHz)

| Atmospheric Conditions | Power-Gain Product, PXG (dBW) | | | | |
|---------------------------|-------------------------------|---------------|-------------------|---------------|-------------------|
| | 1 Mile Range | 2 Miles Range | 3 Miles Range | 4 Miles Range | 5 Miles Range |
| Clear | -10.9 (81 mW) | -4.7 | -1.0 (0.7943W) | 1.7 | 3.8 (2.399 W) |
| Rain 1 mm/hr | -10.3 | -4.6 | -0.8 | 2.1 | 4.3 |
| Rain 4 mm/hr | -10.1 | -3.0 | 1.7 | 5.2 | 8.2 |
| Rain 16 mm/hr | -6.9 (0.2 W) | 3.4 | 11.0 (12.59 W) | 17.7 | 23.8 (239.9 W) |
| Snow, Dry 4 mm/hr | -10.8 | -4.4 | -0.6 | 2.3 | 4.6 |
| Snow, Wet 4 mm/hr | -10.8 | -4.4 | -0.6 | 2.3 | 4.6 |
| Fog, 100 ft Visibility | -8.9 (0.13 W) | -0.7 | 5.1 (3.24 W) | 9.8 | 13.9 (24.55 W) |

Table II-6. Transponder Power-Gain Product (PXG) Required to Produce an SNR of 13.8 dB in ASMI (DECCA) Radar Receiver with 16-dB Noise Figure (Frequency – 35 GHz)

| Atmospheric Conditions | Power-Gain Product, PXG (dBW) | | | | |
|----------------------------------|-------------------------------|---------------|-------------------|---------------|------------------------------------|
| | 1 Mile Range | 2 Miles Range | 3 Miles Range | 4 Miles Range | 5 Miles Range |
| Clear | -3.4 (0.4571 W) | 2.8 | 6.4 (4.365 W) | 9.0 | 11.1 (12.88 W) |
| <i>0.04"/hr</i> Rain 1 mm/hr | -2.9 | 3.9 | 8.1 | 11.2 | 13.8 |
| <i>0.16"/hr</i> Rain 4 mm/hr | -0.9 | 7.8 | 13.9 | 19.0 | 23.6 |
| <i>0.64"/hr</i> Rain 16 mm/hr | 7.0 (5.012 W) | 23.4 | 37.4 (5495 W) | 50.3 | 62.6 (1.82 X 10 ⁶ W) |
| Snow, Dry 4 mm/hr | -3.3 | 3.0 | 6.7 | 9.4 | 11.5 |
| Snow, Wet 4 mm/hr | -3.3 | 3.0 | 6.7 | 9.4 | 11.5 |
| Fog, 100 ft Visibility | -0.3 | 9.0 | 15.7 (37.15 W) | 21.5 | 26.6 (457.1 W) |

Table II-7. Radar Cross Section Necessary to Produce an SNR of 13.8 dB in ASD (T.I.) Radar Receiver with 11-dB Noise Figure (Frequency – 16.5 GHz)

| Atmospheric Conditions | Radar Cross Section (dBsm) | | | | |
|---------------------------|----------------------------|---------------|---------------|---------------|---------------|
| | 1 Mile Range | 2 Miles Range | 3 Miles Range | 4 Miles Range | 5 Miles Range |
| Clear | -11.4 | 0.8 | 8.0 | 13.0 | 17.0 |
| Rain 1 mm/hr | -10.4 | 1.4 | 8.6 | 13.9 | 18.0 |
| Rain 4 mm/hr | -6.4 | 3.9 | 11.3 | 17.1 | 21.9 |
| Rain 16 mm/hr | 1.1 | 11.0 | 20.6 | 29.5 | 37.5 |
| Snow, Dry 4 mm/hr | -8.6 | 1.8 | 8.5 | 13.5 | 17.4 |
| Snow, Wet 4 mm/hr | 0.9 | 7.7 | 12.3 | 16.0 | 19.2 |
| Fog, 100 ft Visibility | -9.4 | 4.8 | 14.0 | 21.0 | 27.0 |

Table II-8. Radar Cross Section Necessary to Produce an SNR Ratio of 13.8 dB in ASD (T.I.) Radar Receiver with 4.5 dB Noise Figure (Frequency -- 16.5 GHz)

| Atmospheric Conditions | Radar Cross Section (dBsm) | | | | |
|---------------------------|----------------------------|---------------|---------------|---------------|---------------|
| | 1 Mile Range | 2 Miles Range | 3 Miles Range | 4 Miles Range | 5 Miles Range |
| Clear | -17.9 | -5.8 | 1.5 | 6.5 | 10.5 |
| Rain 1 mm/hr | -14.9 | -4.5 | 2.4 | 7.5 | 11.6 |
| Rain 4 mm/hr | - 8.0 | -0.2 | 6.0 | 11.2 | 15.8 |
| Rain 16 mm/hr | 0.6 | 7.9 | 15.3 | 23.3 | 31.1 |
| Snow, Dry 4 mm/hr | -10.9 | -2.7 | 3.1 | 7.7 | 11.3 |
| Snow, Wet 4 mm/hr | 0.7 | 6.9 | 10.8 | 13.7 | 16.1 |
| Fog, 100 ft Visibility | -15.9 | -1.8 | 7.5 | 14.5 | 20.5 |

Table II-9. Radar Cross Section Necessary to Produce an SNR of 13.8 dB in ASDE II (AIL) Radar Receiver with 17-dB Noise Figure (Frequency -- 24 GHz)

| Atmospheric Conditions | Radar Cross Section (dBsm) | | | | |
|---------------------------|----------------------------|---------------|---------------|---------------|---------------|
| | 1 Mile Range | 2 Miles Range | 3 Miles Range | 4 Miles Range | 5 Miles Range |
| Clear | -22.2 | -9.8 | -2.4 | 3.0 | 7.3 |
| Rain 1 mm/hr | -20.7 | -9.1 | -1.8 | 3.8 | 8.2 |
| Rain 4 mm/hr | -16.4 | -5.4 | 3.2 | 10.1 | 16.0 |
| Rain 16 mm/hr | - 7.6 | 6.8 | 21.7 | 35.0 | 47.2 |
| Snow, Dry 4 mm/hr | -18.8 | -8.3 | -1.2 | 4.4 | 8.8 |
| Snow, Wet 4 mm/hr | - 9.0 | -2.2 | 2.6 | 6.6 | 10.2 |
| Fog, 100 ft Visibility | -18.2 | -1.7 | 9.8 | 19.2 | 27.4 |

Table II-10. Radar Cross Section Necessary to Produce an SNR of 13.8 dB in ASMI (DECCA) Radar Receiver with 16-dB Noise Figure (Frequency -- 35 GHz)

| Atmospheric Conditions | Radar Cross Section (dBsm) | | | | |
|---------------------------|----------------------------|---------------|---------------|---------------|---------------|
| | 1 Mile Range | 2 Miles Range | 3 Miles Range | 4 Miles Range | 5 Miles Range |
| Clear | -7.5 | 4.9 | 12.1 | 17.3 | 21.4 |
| Rain 1 mm/hr | -5.1 | 7.3 | 15.5 | 21.7 | 26.9 |
| Rain 4 mm/hr | 0.3 | 15.1 | 27.1 | 37.3 | 46.4 |
| Rain 16 mm/hr | 13.7 | 46.1 | 74.0 | 99.8 | 124.5 |
| Snow, Dry 4 mm/hr | -3.6 | 6.4 | 13.2 | 18.3 | 22.5 |
| Snow, Wet 4 mm/hr | 9.5 | 15.9 | 19.9 | 23.1 | 25.9 |
| Fog, 100 ft Visibility | -1.3 | 17.3 | 30.8 | 42.2 | 52.5 |

Table II-11. Total Active Reflector Gain Required to Produce an SNR of 13.8 dB in ASD (T.I.) Radar Receiver with 11-dB Noise Figure (Frequency -- 16.5 GHz)

| Atmospheric Conditions | Active-Reflector Gain (dB) | | | | |
|---------------------------|----------------------------|---------------|---------------|---------------|---------------|
| | 1 Mile Range | 2 Miles Range | 3 Miles Range | 4 Miles Range | 5 Miles Range |
| Clear | 17.3 | 23.4 | 26.9 | 29.5 | 31.5 |
| Rain 1 mm/hr | 17.8 | 23.7 | 27.3 | 29.9 | 32.0 |
| Rain 4 mm/hr | 19.8 | 24.9 | 28.6 | 31.5 | 33.9 |
| Rain 16 mm/hr | 23.5 | 28.4 | 33.3 | 37.7 | 41.7 |
| Snow, Dry 4 mm/hr | 18.7 | 23.9 | 27.2 | 29.7 | 31.7 |
| Snow, Wet 4 mm/hr | 23.4 | 26.8 | 29.1 | 31.0 | 32.5 |
| Fog, 100 ft Visibility | 18.3 | 25.4 | 29.9 | 33.5 | 36.4 |

Table II-12. Total Active Reflector Gain Required to Produce an SNR of 13.8 dB in ASD (T.I.) Radar Receiver with 4.5-dB Noise Figure (Frequency - -16.5 GHz)

| Atmospheric Conditions | Active-Reflector Gain (dB) | | | | |
|---------------------------|----------------------------|---------------|---------------|---------------|---------------|
| | 1 Mile Range | 2 Miles Range | 3 Miles Range | 4 Miles Range | 5 Miles Range |
| Clear | 14.1 | 20.1 | 23.7 | 26.2 | 28.2 |
| Rain 1 mm/hr | 15.6 | 20.8 | 24.2 | 26.7 | 28.8 |
| Rain 4 mm/hr | 19.0 | 22.9 | 26.0 | 28.6 | 30.8 |
| Rain 16 mm/hr | 23.3 | 26.9 | 30.6 | 34.6 | 38.5 |
| Snow, Dry 4 mm/hr | 17.6 | 21.7 | 24.5 | 26.8 | 28.6 |
| Snow, Wet 4 mm/hr | 23.3 | 26.4 | 28.3 | 29.8 | 31.0 |
| Fog, 100 ft Visibility | 15.1 | 22.1 | 26.7 | 30.2 | 33.2 |

Table II-13. Total Active Reflector Gain Required to Produce an SNR of 13.8 dB in ASDE II (AIL) Radar Receiver with 17-dB Noise Figure (Frequency - -24 GHz)

| Atmospheric Conditions | Active-Reflector Gain (dB) | | | | |
|---------------------------|----------------------------|---------------|---------------|---------------|---------------|
| | 1 Mile Range | 2 Miles Range | 3 Miles Range | 4 Miles Range | 5 Miles Range |
| Clear | 13.5 | 19.7 | 23.4 | 26.0 | 28.2 |
| Rain 1 mm/hr | 14.2 | 20.0 | 23.7 | 26.4 | 28.6 |
| Rain 4 mm/hr | 16.4 | 21.9 | 26.1 | 29.6 | 32.5 |
| Rain 16 mm/hr | 20.8 | 27.9 | 35.4 | 42.0 | 48.1 |
| Snow, Dry 4 mm/hr | 15.2 | 20.4 | 24.0 | 26.7 | 28.9 |
| Snow, Wet 4 mm/hr | 20.1 | 23.5 | 25.8 | 27.8 | 29.6 |
| Fog, 100 ft Visibility | 15.5 | 23.7 | 29.4 | 34.1 | 38.2 |

Table II-14. Total Active Reflector Gain Required to Produce an SNR of 13.8 dB in ASMI (DECCA) Radar Receiver with 16-dB Noise Figure (Frequency – 35 GHz)

| Atmospheric Conditions | Active-Reflector Gain (dB) | | | | |
|---------------------------|----------------------------|---------------|---------------|---------------|---------------|
| | 1 Mile Range | 2 Miles Range | 3 Miles Range | 4 Miles Range | 5 Miles Range |
| Clear | 22.5 | 28.6 | 32.2 | 34.8 | 36.9 |
| Rain 1 mm/hr | 23.7 | 29.8 | 33.9 | 37.0 | 39.6 |
| Rain 4 mm/hr | 26.3 | 33.7 | 39.7 | 44.8 | 49.4 |
| Rain 16 mm/hr | 33.0 | 49.2 | 63.2 | 76.1 | 88.4 |
| Snow, Dry 4 mm/hr | 24.4 | 29.4 | 32.8 | 35.3 | 37.4 |
| Snow, Wet 4 mm/hr | 30.9 | 34.1 | 36.1 | 37.7 | 39.1 |
| Fog, 100 ft Visibility | 25.6 | 34.8 | 41.5 | 47.3 | 52.4 |

Two types of ASD (T.I.) 16.5 GHz radars were considered in the calculations. One had a receiver with 11-dB NF and the other had a receiver with 4.5 dB NF.

Tables II-3 through II-14 indicate that the target-enhancement requirements are least stringent for the ASD (T.I.) radar employing the low-noise-parameter amplifier receiver. The ASMI radar, operating at 35 GHz, requires the greatest target enhancement. For example, at 5 miles the effective transponder radiated power (transmitter plus antenna gain less transponder losses) necessary to produce an SNR of 13.8 dB in the ASD receiver (4.5 dB NF receiver) is 3.3 watts under the most severe weather conditions (16 mm/hr rain). To produce an SNR ratio of 13.8 dB in the ASMI (Decca) receiver operating under the same environment, 1.82 MW of effective transponder radiated power is needed. Under the same conditions the gain of an active retrodirective array (defined here as the one-way antenna gain plus one-half the reflection amplifier gain) must be 38.5 dB when the ASD receiver is used, but 88.4 dB when the ASMI receiver is used.

The results on target radar cross section (shown in Tables II-7, II-8, II-9, and II-10) indicate that frequency is one of the most important parameters to be considered for radars operating under adverse weather conditions. Although the ASDE and ASMI radars employ antennas with significantly higher gain (narrower beamwidths) than the ASD radar, the performance of the ASD radar under adverse conditions is better. This is primarily due to the fact that weather clutter backscatter and attenuation are less at lower frequencies. However, a 1000-m² (30 dBsm radar cross section) target is required when the best performing ASD (noise figure = 4.5 dB receiver) radar operates in 16 mm/hr rainfall. If a simple corner reflector is considered as a possible device for target enhancement for this application, a linear

length of 31 inches would be required for a range of 5 miles when rainfall is 16 mm/hr and 10 inches when the weather is clear*.

Some consideration was given to a Van Atta array, to obtain the required RCS. For passive arrays, the number of elements required is impractical. For example, if the required RCS is 30 dBsm then the required two way gain of an array of linear elements is of the order of 75 dB. The number of linear elements required to give a one-way gain of 38 dB is nearly 6400. It is evident that some type of active beacon or transponder is necessary to obtain sufficient gain.

The required performance characteristics of a target enhancement device at a range of 5 miles and 16 mm/hr of rainfall and a radar receiver SNR of 13.8 dB are listed in Table II-15. The target enhancement requirements are least stringent for the ASD (T.I.) radar (SNR = 4.5 dB). A 10 dB reduction in the radar receiver noise figure at 24 GHz and 35 GHz would reduce the required output power of a beacon transponder to 24 W and 182 kW, respectively. A peak pulse output power of 24 W at 24 GHz is feasible with IMPATT diodes in some form of a combining circuit but the design would not be low cost in the immediate future. To achieve 182 kW at 35 GHz is not feasible using solid-state devices.

Table II-15. Target-Enhancement Requirements for Various ASD Radars at a Range of Five Miles with SNR of 13.8 dB and 16 mm/hr Rainfall

| Target Enhancement Technique | Radars | | | |
|---|------------------------|----------|-------------------------|------------------------|
| | ASD (T.I.) 16.5 GHz | | ASDE II (AIL) 24 GHz | ASMI (Decca) 35 GHz |
| | 4.5 dB NF** | 11 dB NF | 17 dB NF | 16 dB NF |
| Beacon Transponder (W) (transponder power gain product) | 3.31 | 14.79 | 239.9 | 1.82 X 10 ⁶ |
| Passive Reflector (dBsm) (radar cross section) | 31.1 | 37.5 | 47.2 | 124.5 |
| Active Reflector (dB) [G (gain) = G _a √G _d] where G = Total gain G _a = Active reflector antenna gain G _d = Active device gain | 38.5 | 41.7 | 48.1 | 88.4 |

* The radar cross section of a corner reflector is given by the relation

$$\sigma = \pi a^4 / 3\lambda^2 \quad (II-7)$$

where a is the length of the edge of the reflector.

** NF = Receiver noise figure

E. CONCLUSIONS

Our conclusions are based on the study of the target-enhancement requirement that the three existing ASD radars achieve a detectable range of 5 miles in all weather conditions. The following is a summary of our results:

- Propagation losses considered at the three frequencies (16.5, 24, and 35 GHz) for all weather conditions are least at 16.5 and maximum at 35 GHz.
- The beacon-transponder technique for increasing the range of detectability of ASD radars is more practical than either the passive-reflector technique or active-reflector technique. The required radar cross-section of 30 dBsm (at 16 GHz) requires too large an area or too many elements for passive reflectors to be useful. The total area or number of linear elements can be reduced by using an active corner reflector or array, but the amplifier gain is limited to about 10 dB by finite isolation between the receiving and transmitting antennas on a small vehicle. Thus for a range of 5 miles and 16 mm/hr of rainfall, beacon-transponder techniques are the only feasible techniques with existing ASD radars.
- The required peak output power of 3.3 W at 16.5 GHz is within the state of the art of direct generating solid state devices. A reduction in the radar receiver noise figure of 10 dB is required to bring the transponder power requirements at 24 GHz within the state of the art of solid state devices.

REFERENCES FOR SECTION II

1. A. Fang, "Comparative Performance of Three Airport Surface Detection Radars," Technical Report TR 71-037, Texas Instruments, Dallas, Texas (1971).

III. CLUTTER AND MULTIPATH-PROPAGATION EFFECTS ON THE PERFORMANCE OF ASD RADARS

A. GENERAL

An investigation of the target-enhancement requirements for ground control of aircraft, vehicles, and personnel using ASD radars operating under various weather conditions was reported in the preceding section. The results were tabulated in Tables II-3 through II-15. These results, however, did not account for ground clutter (terrain backscatter) or multipath-propagation (terrain forward scatter). Both phenomena will have an effect on the performance of the ASD radars, particularly when they are operating at low elevation angles in the airport or jungle environment. A complete study on this subject is beyond the terms of this contract and hence has not been reported in depth. However, references are included for the benefit of the reader who would like to perform a detailed study.

Ground clutter increases the overall system noise, which means that for a given target range, a larger target radar cross section is required to maintain the same receiver SNR. On the other hand, multipath-propagation affects the total received signal at the radar because of the wide variation of received energy as target elevation angle changes. These variations result because of multipath interference, which creates multiple antenna-pattern elevation lobes. Multipath also causes false-target indications and affects clutter rejection in certain cases.

B. CLUTTER EFFECTS

1. Ground-Clutter Effects

The amount of ground-clutter return is proportional to the area illuminated by the radar. Most of the clutter return is from an area illuminated by the main beam of the radar antenna, but sidelobe illumination can also contribute to the clutter area seen by the radar. This is particularly true for surface radars tracking low-elevation targets. Hence, to properly account for all ground clutter, the antenna pattern must be accurately known. For low elevation angles the area illuminated by the main beam of the antenna is approximated by

$$A_v \cong crR \tan\left(\frac{\theta_B}{2}\right) \sec(\psi) \quad (\text{III-1})^*$$

*The parameters of this and subsequent equations are defined in Section II, following Eq. (II-6), except as otherwise noted.

where ψ is the grazing angle which, when a curved instead of flat earth (4/3 earth approximation) is being considered, is approximately equal to

$$\psi \cong \sin^{-1} \left(\frac{h}{R} - \frac{R}{2r_e} \right) \quad (III-2)$$

where

h = Antenna height and

r_e = 4/3 the actual radius of the earth ($\cong 8.5 \times 10^6$ m) .

Thus, the received ground clutter may be determined from the radar equation:

$$N_c = \frac{P_t G_t \lambda^2 G_r (10)^{-\alpha R}}{(4\pi)^3 R^4 L_s} \cdot A_c \sigma_c^\circ \quad (III-3)$$

The backscattering coefficient, σ_c° , given in terms of scattering cross section per unit area, is a measure of the backscattering characteristics of the ground. This coefficient depends on radar-system parameters that include wavelength, angle of incidence, and polarization, and terrain parameters that include complex permittivity and roughness of both the ground surface and subsurface. Theoretical models are described in the literature¹⁻¹² that attempt to derive the dependence of σ_c° on the above parameters. Such models, however, are very limited in their validity primarily because of the extreme difficulty in accurately describing representative terrain mathematically in terms of its electrical and physical properties.¹³ Many programs in the past have been completed that measured the scattering coefficient of the ground.¹⁴⁻²³ It appears that no useful data are available from the controlled measurements.¹³ For the ASD radars, only values of σ_c° for circular polarization are applicable, since these radars employ circularly polarized antennas. However, no theoretical or measured data of σ_c° have been presented for horizontal and vertical polarization, but since only amplitude and not phase information is contained in these backscatter coefficients, values for the case of circular polarization cannot be derived from these data.

2. A Solution to Ground-Clutter Effects

Frequency-discrimination techniques can be used as a means of extracting target signal information from clutter and effectively increasing the signal-to-clutter ratio at the radar receiver. Most commonly, these techniques are employed in MTI* and pulse-Doppler radars²⁴ where the frequency difference (doppler shift) between the signal received from a moving target and the clutter received from fixed targets is used to extract the signal from clutter. Pulse radars, such as the ASD radars, can also use a frequency-discrimination technique for clutter suppression if the target is configured with a beacon transponder. With this technique, the radar transmitter and receiver are tuned to different frequencies, and the transponder receiver and transmitter are tuned, respectively, to the radar transmitter and receiver. This was one of the cases considered during evaluation of the target-enhancement requirements for the ASD radars where the assumption was made that clutter rejection was complete.

*Moving Target Indicator.

3. Other Clutter Effects

There are, of course, other types of clutter targets besides the surface of the ground that should be accounted for during consideration of terrain clutter. Clutter targets such as buildings, towers, and bare hills or mountains are fixed and reflect signals that are constant in both phase and amplitude with time. Clutter signals from trees, weeds, and other foliage (and also from rain) fluctuate with time, however, producing a spectral distribution of clutter energy given by

$$W(f) = W_o \exp\left(-a \frac{f^2}{f_t^2}\right). \quad (III-4)$$

This equation describes the received spectral density of clutter surrounding each transmitted spectral line at frequency f_t , with a power density of W_o . The frequency deviation about each line is f ; the parameter a describes the relative stability of the particular kind of clutter and is a function of wind speed.²⁵ Clutter from these fluctuating targets can limit the ASD radar receiver capability to reject clutter when tracking a transponder augmented target. This is because within the spectral distribution of clutter energy, a clutter signal at the same frequency as the signal from the transponder can exist.

C. MULTIPATH-PROPAGATION EFFECTS

Multipath propagation, as applicable to the ASD radars, can cause target fading and false-target detection,* and reduce the effectiveness of rain clutter cancellation of circularly polarized radars.

1. Target Fading

Target fading is due to the destructive interference between the direct wave reaching the target and an indirect wave, reflected from the ground surface, reaching the target. The average power in the total field intercepted by the target is proportional to

$$P \propto E_d^2 \left| \left[1 + K_\theta \rho_s e^{j\beta(R-R_s)} \right] \right|^2 = E_d^2 \left| \left[1 + K_\theta |\rho_s| e^{j\varphi} \right] \right|^2 \quad (III-5)$$

where

E_d = Field component of the direct wave

$K_\theta = \frac{G_\theta}{G}$, where G_θ = the antenna gain in the direction of the indirect wave, and G = the antenna gain in the direction of the beam peak

ρ_s = Complex (forward-scatter) reflection coefficient of the ground surface

R_s = Indirect path length between the radar and target

$\beta = \frac{2\pi}{\lambda}$.

*Indication of a target in a position where no target exists.

If the ground surface is smooth and is a good conductor, $\rho_s = -1$. In general, however, ρ_s depends on the same parameters as the ground-clutter backscattering coefficient, σ_c° (namely, wavelength), the angle of incidence of the indirect wave, polarization, and the electrical and physical properties of the ground.²⁶ From Eq. (III-5) it is seen that as the range to the target (R) changes, φ will vary between 0 and 2π . When $\varphi = \pi$, maximum target fading occurs that is most serious at low elevation angles as K_θ approaches 1.

2. False-Target Detection

False-target detection can result when a radar signal is reflected from mountains or from other fixed targets such as buildings or towers, toward a target. In this case, target detection occurs when the antenna is pointed toward the reflecting surface instead of toward the target, resulting in a false-azimuth-position indication. False-target detection becomes a greater problem when the target carries a transponder. The transponder can be triggered by a reflected transmitted signal that is typically 20 to 25 dB down from the direct-path signal.²⁷ Fortunately, however, radar sidelobe-suppression (SLS) techniques²⁸ can be used to eliminate most transponder replies to main-beam reflected signals.*

3. Increased Rain Clutter

Multipath surface reflections also reduce the effectiveness of rain-clutter cancellation in the ASD radars, which transmit and receive circularly polarized signals.^{29,30} The reason can be understood if one first considers why rain-clutter cancellation is accomplished with circularly polarized radars. When a circularly polarized wave is reflected by a general target, it breaks up into two circularly polarized wave components. The electric-field vector of one component rotates clockwise and the field vector of the other component, counterclockwise.[†] When the target is nearly symmetrical, such as a raindrop, most of the energy is in the component that is cross-polarized to the transmitted (or incident) wave. This is because the wave reflected by a raindrop has essentially the same relative phase and amplitude relationships between the horizontal and vertical electric-field components as does the incident wave, yet the direction of propagation is reversed.[‡] Since the radar antenna can transmit and receive only one sense of circular polarization, most of the clutter return is rejected.

Although the direct wave from an ASD radar will be circularly polarized with low axial ratio, the ground-reflected wave will be elliptically polarized. This is due to the relative phase and amplitude relationships of the horizontal and vertical field components being markedly changed upon reflection from the ground. When this ground-reflected wave is in turn reflected from the rain, a significant fraction of the wave will be accepted by the radar antenna. Hence, more rain-clutter energy is received by the radar antenna. Thus it is seen that multipath effects should also be considered when the clutter-reduction factors for the ASD radars operating in a rainfall environment are being determined.

*Transponders at considerable ranges from the interrogation radar can be triggered when in the radar antenna sidelobes. This gives rise to a "ring-around" effect on a PPI display of a scanning radar resulting in loss of azimuth accuracy, angle resolution, and increased interference. Sidelobe-suppression systems are designed to eliminate transponder responses to sidelobe interrogations.²⁷

[†]The composite wave is elliptically polarized.

[‡]The sense of polarization is defined by the direction of rotation of the electric-field vector in a transverse plane as seen by an observer looking in the direction of propagation. Clockwise rotation corresponds to right-hand elliptical or circular polarization, and counterclockwise to left-hand polarization.

D. CONCLUSIONS

Clutter and multipath propagation effects can degrade the performance of the ASD radars. These effects are dependent on the environment in which the radars are placed and the surrounding weather conditions. Therefore, before an ASD radar is used in a specified place, we suggest that a system propagation study of possible ground or multipath effects be performed.

Ground-clutter effects can be eliminated if frequency-discrimination techniques are used as a means of extracting target-signal information at a frequency other than that of the return signals from the ground or other fixed objects in the vicinity of the radar. Also, by proper separation of transmitted and received signal frequencies to the radar it may be possible to reduce clutter signals due to trees, weeds, and other foliage. Frequency-discrimination techniques can be applied for target-enhancement purposes by the use of cooperative beacon transponders.

Rain clutter can be reduced by using circularly polarized antennas in the radar.

Multipath-propagation will occur and cause target fading and false-target detection, and reduce effectiveness of rain-clutter cancellation in the case of circularly polarized antennas. Achieving a reduction of these effects may require more sophisticated transmission or detection schemes (two or three antenna systems and possible multiple radar installations). Detailed study and analysis on this topic is not within the scope of our present investigation.

REFERENCES FOR SECTION III

1. W.H. Peake, "Theory of Radar Return from Terrain," *1959 IRE National Convention Record*, Part 1, pp. 27-41 (March 1959).
2. L.M. Spetner and I. Katz, "Radar Terrain Return: A Theoretical Approach," *Transaction of the 1959 Symposium on Radar Return*, NOTS TP 2338, Part 1, pp. 91-109 (May 1959).
3. G.T. Ruck, ed., *Radar Cross Section Handbook*, Vol. 2, Chap. 9 (Plenum Press, New York, N.Y., 1970).
4. R.E. Clapp, "A Theoretical and Experimental Study of Radar Ground Return," *MIT Radiation Lab*, Report 6024 (April 1946).
5. A.I. Dymova and I.A. Vorontsov, "Calculation of the Region of Passive Noise from the Earth's Surface," *RadioTekhnika*, Vol. 27, pp. 1-5 (February 1972).
6. J.A. Cooper, et al., "Antenna-Polarization and Terrain-Depolarization Effects on Radar Return from the Ground," *1968 WESCON Convention Record*, Vol. 12, Part 1, pp. 1-12 (August 1968).
7. G.R. Valenzuela and M.B. Laing, "Point Scatterer Formulation of Terrain Clutter Statistics," Report 750668 NRL-7459, NRL, Washington, D.C. (September 1972).
8. S.Rosenbaum and L.W. Bowles, "Clutter Return from Vegetated Areas," Report TN-1971-34, Lincoln Lab., Lexington, Mass. (September 1971).
9. N.I. Durlach, "Influence of the Earth's Surface on Radar," Report TR-373, Lincoln Lab., Lexington, Mass. (January 1965).
10. R.C. Taylor, "The Terrain Scattering Problem," Report NSG-213-61, Antenna Lab., Ohio State Univ., Columbus, Ohio (April 1964).
11. L.M. Spetner and I. Katz, "Further Analysis of Radar Terrain Return," Report CF-2843, APL, Johns Hopkins Univ., Silver Spring, Md. (November 1959).
12. W.H. Peake, "Simple Model of Radar Return from Terrain," Report 694-3, Antenna Lab., Ohio State Univ., Columbus, Ohio (September 1957).
13. M.I. Skolnik, ed., *Radar Handbook*, Chap. 25 (McGraw-Hill Book Co., New York, N.Y., 1970).
14. R.C. Taylor, "Terrain Return Measurements at X, K_U, and K_a Band," *1959 IRE National Convention Record*, Part 1, pp. 19-26 (March 1959).
15. C.R. Grant and B.S. Yaplee, "Backscattering from Water and Land at Centimeter and Millimeter Wavelengths," *Proc. IRE*, Vol. 45, pp. 967-982 (July 1957).
16. J.R. Lundien, "Terrain Analysis by Electromagnetic Means: Radar Responses to Laboratory Prepared Soil Samples," *U.S. Army Waterways Expt. Sta. Tech. Report 3-639*, Report 2 (1966).

17. A.R. Edison, "An Acoustic Simulator for Modeling Backscatter of Electromagnetic Waves," *Univ. New Mexico Engr. Expt. Sta. Tech. Report EE-62* (September 1961).
18. B.E. Parkins and R.K. Moore, "Omnidirectional Scattering of Acoustic Waves from Rough Surfaces of Known Statistics," *J. Acous. Soc. Am.*, Vol. 50, pp. 170-175 (1966).
19. R.K. Moore, "Acoustic Simulation of Radar Returns," *Microwaves*, Vol. 1, pp. 20-25 (December 1962).
20. T. Willie, et al., "NRL Terrain Clutter Study: Phase II," Report NRL-6749, NRL, Washington, D.C. (October 1968).
21. N. Guinard and J. Ransone, "NRL Terrain Clutter Study, Phase I," Report NRL-6487, NRL, Washington, D.C. (May 1967).
22. F.E. Nathanson, et al., "Report of Radar Clutter Signal Processing Committee, Part 1, Radar Clutter Effects," Report TG-842-1, APL, Johns Hopkins Univ., Silver Spring, Md. (September 1966).
23. E.A. Wolff, "A Review of Theories and Measurements of Radar Ground Return," Report CRC-5198-2, Electromagnetic Research Corp., College Park, Md. (February 1960).
24. M.I. Skolnik, *Introduction to Radar Systems*, Chap. 4 (McGraw-Hill Book Co., New York, N.Y., 1970).
25. D.K. Barton, *Radar System Analysis*, Chap. 3 (Prentice-Hall Inc., Englewood Cliffs, N.J., 1964).
26. P. Beckman and A. Spizzichino, *The Scattering of Electromagnetic Waves from Rough Surfaces* (The MacMillan Co., New York, N.Y., 1963).
27. M.I. Skolnik, ed., *Ibid.*, Chap. 38.
28. J. Croney and P.R. Wallis, "A Side-Lobe Suppression System for Primary Radar," *Radio and Electronic Engineer*, Vol. 28, pp. 247-258 (October 1964).
29. R. McFee and T.M. Maher, "Effect of Surface Reflections on Rain Cancellation of Circularly Polarized Radars," *IRE Trans. on Antennas and Propagation*, Vol. AP-7, pp. 199-201 (April 1959).
30. E.W. Beasley, "Effect of Surface Reflections on Rain Cancellation in Radars Using Circular Polarization," *Proc. IEEE*, Vol. 54, pp. 2000-2001 (December 1966).

IV. COOPERATIVE-BEACON-TRANSPONDER DESIGNS AND CONCEPTS

A. GENERAL

We have used the term "cooperative beacon transponder" here as opposed to beacon transponder in order to discriminate positively between these two types. The cooperative beacon transponder discussed in this report is a transponder whose output pulsed signal is synchronized with the received pulsed signals from the tracking or surface-detection radar. The input and output frequencies of the cooperative beacon transponder may be the same or different, depending on the design and system requirements. In this report (all sections), for brevity the expression "beacon transponder" is used to designate the cooperative beacon transponder.

In the following subsections, cooperative-beacon-transponder specifications, design goals, design techniques, and design concepts are discussed in detail. The design techniques and concepts discussed are not for any specific frequency and could apply in a variety of applications.

B. BEACON-TRANSPONDER SPECIFICATION FOR THREE ASD RADARS

A transponder consists of a receiver, transmitter, and antenna. Complexity of the transponder depends on the electrical functions it must perform. Concepts of simple transponders are shown in Figure IV-1.

The transponder specifications are those of the receiver, transmitter, and antenna that collectively form one integrated system. Each of these components is considered separately in the following subsections.

1. Antenna Specifications

The antenna should be omnidirectional and elevated so that the main lobes of the field strength are in the direction of the radars mounted on the towers. Sidelobes to the ground should be minimized in the design. The antenna must be mounted on the top surface of the vehicle or the aircraft so there is no obstruction in the path of transmission or reception. The same antenna would be used for transmission as well as reception, to keep the cost of the transponder beacon to a minimum. The antenna must be of a simple design, so no gain can be expected. Any additional microwave power required from the transponder will be supplied by the solid-state source in the transmitter. No detailed antenna studies have been performed for this report. It is expected that a simple quarter-wavelength dipole covered with a radome for protection against rain could satisfy the needs for a low-cost beacon transponder.

2. Transmitter Specifications

In Tables II-3 through II-6, the transponder RF output-power requirements are tabulated for distances of one mile through 5 miles for different ASD radars under various atmospheric conditions. The peak RF power levels listed in those tables must be generated by the transmitter in the beacon transponder so that an SNR of 13.8 dB exists at the ASD radar receivers.

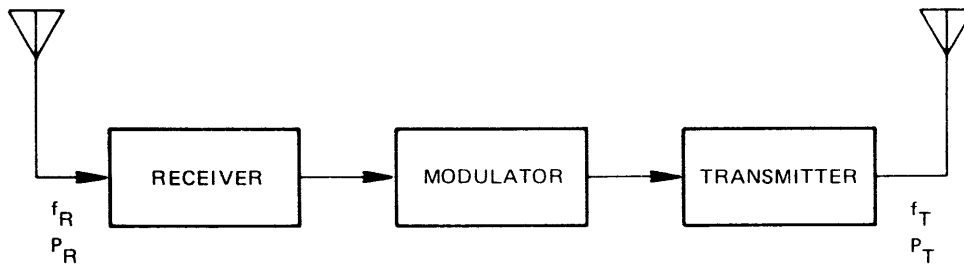

(a) TWO-ANTENNA TRANSPONDER

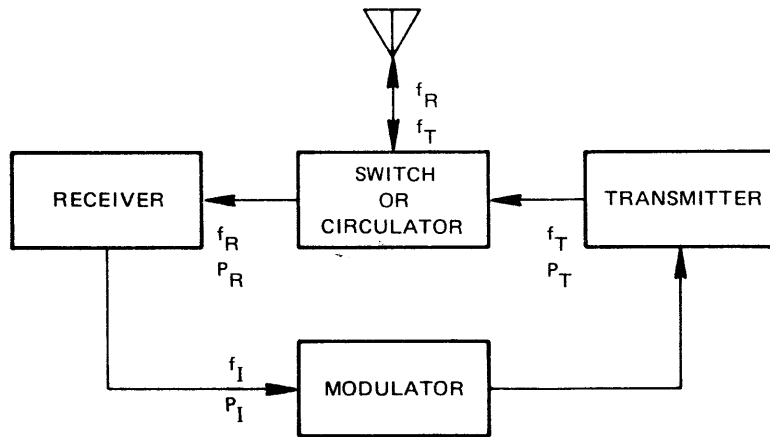

(b) ONE-ANTENNA TRANSPONDER

SA-1970-3

FIGURE IV-1 SIMPLE TRANSPONDER CONCEPTS

3. Receiver Specifications

In order to list the receiver specifications for a beacon transponder, it is necessary to apply the radar range equations to the various ASD radars at 16.5 GHz, 24 GHz, and 35 GHz to predict the power received at the beacon.

The power received at the beacon receiver (taking into consideration the losses due to circular polarization and atmospheric conditions can be determined from the following equation:

$$P_r = \frac{G_t}{L_t} \cdot \frac{G_p}{L_s} \cdot P_t \cdot \left(\frac{1}{4\pi R^2} \cdot \frac{\lambda^2}{4\pi} \cdot (10)^{-\frac{1}{2}\alpha R} \right) \quad (IV-1)$$

where

- L_t = 4 dB (expected). Loss due to circular polarization, — i.e., if beacon antenna is linearly polarized.
- L_s = 8 dB (expected). System loss at radar and beacon receiver due to radome loss, rotary joint loss, and waveguide loss.
- G_p = 1.64 or 2.2 dB for a simple quarter-wavelength dipole.
- α = Attenuation loss constant due to atmospheric condition.

For simplicity of design and cost-saving purposes, no sophisticated integration will be performed in the beacon receiver.

Attenuation loss in decibels (given by $\log_{10} 10^{-\frac{1}{2}\alpha R}$) due to rainfall of 16 mm/hr (worst condition) at the various frequencies of interest is summarized as follows:

| Frequency (GHz) | Loss/Mile |
|-----------------|---------------|
| 16.5 | 2.085 dB/mile |
| 24.0 | 4.17 dB/mile |
| 35.0 | 10.43 dB/mile |

By application of Eq. (IV-1) to the various ASD radars, the received power at the beacon transponder can be calculated.

In Tables IV-1 and IV-2 each term in Eq. (IV-1) is listed in decibels for the three ASD radar at 16.5 GHz, 24 GHz, and 35 GHz for one-mile range and five-mile range, respectively. The received power is then calculated for both clear and 16-mm/hr rainfall weather conditions by addition of all the terms in decibels for a range of one mile and 5 miles, respectively.

Diode detectors are commercially available with tangential sensitivities of -44 dBm at 16.5 GHz, -38 dBm at 24 GHz, and -35 dBm at 35 GHz for 100 MHz bandwidth. A review of results on the received power at the beacon transponder as shown in Table IV-1 for 1-mile target distance from the radar indicates that a video detector (with large bandwidth that will maintain the pulse shape of the received signal) could be used as a receiver in the beacon transponder at 16.5 and 24 GHz. Since tangential sensitivity corresponds to an SNR of 3 dB, the video detector cannot be used for ASMI radar at 35 GHz when rainfall is 16 mm/hr. It is assumed that in order for the transponder system to meet the system specification, the probability of detection must be 0.95 and the SNR a minimum of 13.8 dB. For a target distance of 5 miles, a simple video detector cannot meet the SNR specifications. An alternative receiver design that will most probably meet the system specification at 35 GHz is a superheterodyne type. The superheterodyne technique would require a local-oscillator drive and would increase the size and cost of a beacon transponder system.

C. BEACON-TRANSPONDER DESIGN GOALS

The goals for transponder design at any frequency are:

- Utilization of common antenna system
- No coupling between transmitter and receiver

Table IV-1. Calculation of Received Power at the Beacon Transponder for Three ASD Radars at a Distance of One Mile

| Radars Range Parameters | ASD (T.I.) 16.5 GHz | ASDE II (AIL) 24 GHz | ASMI (Decca) 35 GHz | | | |
|--|---------------------------|----------------------------|---------------------------|------------------|------------|------------------|
| P_T (Effective Radiated Peak Power) | +75.2 dBm | +75.6 dBm | +70. dBm | | | |
| G_T (Radar Antenna Gain) | +33.0 dB | +45.0 dB | +42.5 dB | | | |
| G_p (Beacon Antenna Gain) | +2.2 dB | +2.2 dB | +2.2 dB | | | |
| L_s (System Loss) | -8.0 dB | -8.0 dB | -8.0 dB | | | |
| L_t (CP Loss) | -4.0 dB | -4.0 dB | -4.0 dB | | | |
| Atmospheric Attenuation* | -120.7 dB | -122.78 dB | -124.2 dB | -128.4 dB | -127.45 dB | -137.88 dB |
| | Clear | 16 mm/hr Rain | Clear | 16 mm/hr Rain | Clear | 16 mm/hr Rain |
| Received Power at the Beacon | -22 dBm | -24.4 dBm | -13.4 dBm | -17.6 dBm | -24 dBm | -34.4 dBm |

*Atmospheric attenuation is given by $\left(\frac{1}{4\pi R^2} \cdot \frac{\lambda^2}{4\pi} \cdot 10^{-\frac{1}{2}R} \right) \alpha \approx 0$ for clear-weather conditions.

- Small size, including antenna
- High efficiency
- Solid state
- Low cost
- Utilization of power supply only when the beacon transponder is illuminated by the ASD radar
- Minimum delay or constant delay.

These goals can be met by proper transponder design techniques. In the following section, beacon-transponder designs and techniques to achieve these design goals are discussed.

Table IV-2. Calculations of Received Power at the Beacon Transponder for Three ASD Radars at a Distance of Five Miles

| Radars Range Parameters | ASD (T.I.) 16.5 GHz | | ASDE II (AIL) 24 GHz | | ASMI (Decca) 35 GHz | |
|--|---------------------------|------------------|----------------------------|------------------|---------------------------|------------------|
| P_T (Effective Radiated Peak Power) | +75.2 dBm | | +75.6 dBm | | +70.8 dBm | |
| G_T (Radar Antenna Gain) | +33.0 dB | | +45.0 dB | | +42.5 dB | |
| G_p (Beacon Antenna Gain) | +2.2 dB | | +2.2 dB | | +2.2 dB | |
| L_s (System Loss) | -8.0 dB | | -8.0 dB | | -8.0 dB | |
| L_t (CP Loss) | -4.0 dB | | -4.0 dB | | -4.0 dB | |
| Atmospheric Attenuation* | -134.7 dB | -145.1 dB | -138.5 dB | -159.2 dB | -141.5 dB | -193.6 dB |
| | Clear | 16 mm/hr Rain | Clear | 16 mm/hr Rain | Clear | 16 mm/hr Rain |
| Received Power at the Beacon | -36.3 dBm | -46.7 dBm | -27.0 dBm | -38.6 dBm | -38.0 dBm | -90.0 dBm |

*Atmospheric attenuation is given by $\left(\frac{1}{4\pi R^2} \cdot \frac{\lambda^2}{4\pi} \cdot 10^{-\frac{1}{2}\alpha R} \right)$

D. GENERAL TRANSPONDER TECHNIQUES

Figure IV-1 shows two simple transponder concepts. The receiver down-converts the RF signal to an IF or video signal. Received information is obtained at the IF or video frequency. The transmitter is modulated with this IF or video signal. An RF signal at a frequency different from that received is generated by the transmitter, then retransmitted, containing all the received information without degradation.

Generally, FM transponder designs are more complex than AM, because they use components with linear phase and constant amplitude within the information passband. In addition, more components are used to cancel the AM effects on the transmission. Both AM and FM transponders at low frequencies would require more components because of stringent selectivity specifications on the transponder receiver and minimum electromagnetic interference or harmonic specifications imposed by the FAA on the transponder transmitter. There are many low-frequency transmitting equipments now in use. Thus, for the beacon

transponder to be fail-safe and reliable, the receiver must be capable of canceling any image signals or spurious false alarms. This requires additional filtering or the use of coding techniques.

Beacon-transponder designs for ASD radars will be simpler than the existing communication transponders that must maintain signal information modulated on the carrier. Pulse-modulation schemes are used in beacon transponders because the ASD radars are pulse-modulated. ASD beacon transponders have a requirement that the transmitted pulse signal have a leading or trailing edge that is synchronized with that of the ASD radar pulse. Synchronization of pulsed RF signals from the beacon transponder must be on a pulse-to-pulse basis. The delay, rise time, and width of the transmitted pulse will determine the range and resolution accuracy of the system. To maintain the same range accuracy and resolution of the ASD radar, pulse waveforms should not be degraded considerably.

Presently ASD radars at 16.5 GHz (or 14.3 GHz), 24 GHz, and 35 GHz use echo techniques for determining the target range. By comparison of the time duration of the pulsed received signal with respect to the pulsed transmitted signal, range information can be predicted. The ASD radar receiver frequency is the same as the transmitter frequency. If beacon transponders are used, the ASD radar receivers may have to be modified. The signals received by the ASD radar receiver include returns from the target, rain, ground, and beacon transponder. In order to differentiate the beacon signal from other signals, the frequency of the signal transmission at ASD radar will be different from that of the signal frequency received from the transponder. The frequencies cannot be very far apart; otherwise, existing components in the ASD radar will have to be modified. It is assumed that the RF circuitry in the ASD radars will remain unchanged, but the local oscillator and the downconverter in the ASD receiver will be modified such that only the beacon-transponder signals are within the IF bandwidth of the radar receiver. In many systems, RF circuits generally have a bandwidth of 5% to 10%. Therefore the maximum beacon-transponder frequency difference from ASD transmitter frequency that one could expect is 2% to 3% (i.e., 480 MHz at 16.5 GHz). This can be confirmed by acquiring more information on the present ASD radars.

There are basically two types of beacon-transponder designs for ASD radars. They are the instantaneous-response types and the delay-response types.

In the instantaneous-response transponder the output signal appears after a very small delay in the received signal. This delay is primarily due to the group delay of the components in the receiver and transmitter. A delay of a few nanoseconds can be expected in this type of transponder. This is very useful, since no compensation is required in the ASD radar receiver. The disadvantage is that all the local-oscillator sources must be operating at all times, and dc power is consumed at all times, thereby limiting the life of a battery. At low frequencies, class C amplifiers can be used in the last stages of the transmitter, limiting the high-power operation to times when a signal is received. However, at high frequencies the negative-resistance amplifiers will drain current from the battery regardless of whether or not a signal is present.

In the delay-response transponder the transmitter is turned ON only when a signal is received from the ASD radar. A delay in the output response occurs because a finite time is required to turn the power supplies ON. In this type of transponder, fewer active high-power solid-state components are required, thereby reducing cost and size.

In order to meet all the beacon-transponder design goals, special techniques must be utilized. Some of the important techniques are discussed in the following paragraphs.

1. Common Antenna System (Isolation of Transmitter and Receiver)

A common antenna system for receiving and transmitting can be utilized by using a transponder design as shown in Figure IV-1 (b). The transmitter and receiver are combined by a circulator, switch, or diplexer. Since active components require power supplies and drive circuitry, the switch will not be considered for low-cost transponder designs in this project. Also, in order to use a switch combining system, memory-logic-pulse signals will be required to operate such a switch. The switch would have to be ON, in the receiver direction at all times. When the signal from an ASD radar is received, the switch will have to be turned ON in the direction of the transmitter. The time duration for switching from receiver direction to transmitter direction will have to be of the order of the received pulsewidth time duration. This type of operation is complex and not necessary if passive components such as a circulator or diplexer can be utilized. Isolation and frequency-selectivity specifications depend on the minimum burn-out level of the first active component (mixer or detector) in the receiver chain and the difference between the received and transmitted frequencies, respectively. A typical diode detector or mixer can handle a maximum of 100 mW power. A simple isolator can give a minimum isolation of 17 dB at a fairly low cost. This isolation is sufficient to decouple the transmitter and receiver if transmitter power is 10 watts maximum. More isolation would be required for high powers. The disadvantage of using an isolator instead of a diplexer is that it is not compatible with stripline or microstrip techniques. Interconnection between the isolator and receiver or transmitter might be a problem because isolators are built on ferrite substrates. For minimum cost and ease of production, the design goals are to have all the transponder RF circuitry on one plane in either stripline or microstrip form. Thus it would be advantageous to have a homogeneous system. This would depend on the frequency of the ASD radar considered and the bandwidth of the system.

2. Size

Minimum size reduction can be achieved by microstrip techniques. However, when the frequencies are greater than 26 GHz the components are small; thus, using stripline or microstrip techniques could be difficult and disadvantageous because of the production control required on the parasitic discontinuities and mechanical tolerances. It should also be noted that OSM connectors cannot be used beyond 26 GHz because of the moding problems in the coaxial line. Therefore waveguide transitional connections should be considered for frequencies beyond 26 GHz. Selection of transmission media (whether it is stripline, microstrip, coaxial, or waveguide) depends on size constraint and production or assembly costs of components.

3. Efficiency

The efficiency of a transponder depends on the efficiency of high-power oscillators and amplifiers used in the transmitter. Solid-state devices used determine the efficiency of the oscillator circuits. At low frequencies (< 5 GHz) transistors can be used. At higher frequencies (> 5 GHz) direct-generation devices such as Gunn, IMPATT, or LSA devices can be used. Transistors are more efficient than the direct-generation devices at present. Efficiencies of 30% to 40% are presently applicable to transistors generating 4 watts CW at 4 GHz. Gunn diodes at X-band and K-band can delivery 1 watt CW and 1/2 watt CW, respectively, with efficiencies of 4% to 6%. Efficiency for transistors and direct-generating devices is covered in a separate section of this report. As technology advances, breakthroughs are expected in the direct-generating devices. Recently 22% efficiency at 6.5 GHz was achieved in GaAs IMPATT diodes by B. Kramer at the Laboratory of Electronics and Physical Applications Limited, France.¹

4. Utilization of Power Supplies when Transponder is Illuminated by ASD Radar

Transponders can be designed so that the power to the transmitter is turned ON only when the transponder is illuminated by a radar. The receiver, which uses negligible power compared to that of the transmitter, can be left ON at all times to detect the radar signal. The output of the receiver is then amplified to turn ON the power supplies of the transmitter. This type of scheme is quite beneficial for beacon transponders that will use constant-voltage lead batteries as the dc power source and where conservation of power is necessary when the aircraft or vehicle engines are not operating. The disadvantage of this scheme is that there will be a constant delay in the transmitted signal. The power supplies have slow rise time and the oscillations will take time to build up in the transmitter. To eliminate such rise-time problems in the transmitter, a fast RF switch can be inserted at the output port to be operated only when the transmitter has reached a steady-state condition.

E. BEACON-TRANSPONDER CONCEPTS

Concepts of beacon transponders depend on the receiver or transmitter used, frequency of operation, and range consideration under all atmospheric conditions. In the following subsections, receiver and transmitter concepts are discussed.

1. Receiver Concepts

There are two basic concepts in AM receiver designs for beacon transponder applications. Figure IV-2 shows the two concepts in block-diagram form. One uses an RF diode detector and the other uses a mixer driven with a local oscillator. Receivers using mixers are sensitive and have a larger dynamic range than receivers using diode detectors. In the case of the diode-detector receiver, an output-pulse envelope will exist whether the input is due to the received signal from the ASD radar or to the leakage across the combining network (Figure IV-1) from the beacon transmitter; in the case of leakage, gating circuits would be required at the output of a diode-detector receiver. The gate is enhanced for no pulse output to the modulator when the beacon transmitter pulse is ON. By utilizing gating circuits, feedback from the beacon transmitter to the receiver can be controlled without the use of an RF bandpass filter (at the input to the receiver) with steep-skirt selectivity to attenuate the transmitter RF signals. However, in the case of a receiver using a mixer, IF signals will be out-of-band when the input RF signal is due to leakage across the combining network (see Figure IV-1). This will occur if received frequency and transmitted frequency of the beacon transponders are different. In-band IF signals are generated only when an RF received signal mixes with the local-oscillator pump. Receivers using diode detectors and gating circuits are simpler and easier to manufacture than receivers driven by a local oscillator. Utilization of either a diode-detector receiver or a mixer receiver will depend primarily on the frequency of the ASD radar and the range requirements.

A typical AM transponder receiver (see Figure IV-3) consists of an RF bandpass filter, a limiter for protection of the mixer, a mixer pumped with LO, an IF amplifier, an IF bandpass for selectivity, a video detector, and a video amplifier. This type of system is complex, expensive and bulky. The most expensive items in such a system are the RF filters, RF limiter, and pre-amplifier. For an ASD radar beacon, we propose either a simple diode detector followed by an IF amplifier, or a mixer pumped by a local oscillator followed by an IF amplifier. These are shown in Figure IV-2. A limiter is not required because the combining network would have sufficient isolation to attenuate the signals from the transmitter. However, for safety it is recommended that a limiter be inserted. RF bandpass filters will not be necessary, since the probability of the existence of RF signals with the same pulse waveform shape is small.

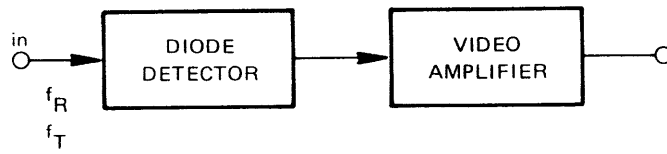

(a) ZERO IF RECEIVER

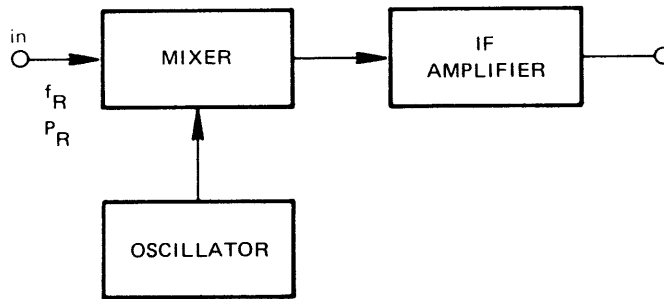

(b) SUPERHETERODYNE RECEIVER

SA-1970-4

FIGURE IV-2 SIMPLE AM RECEIVER CONCEPTS

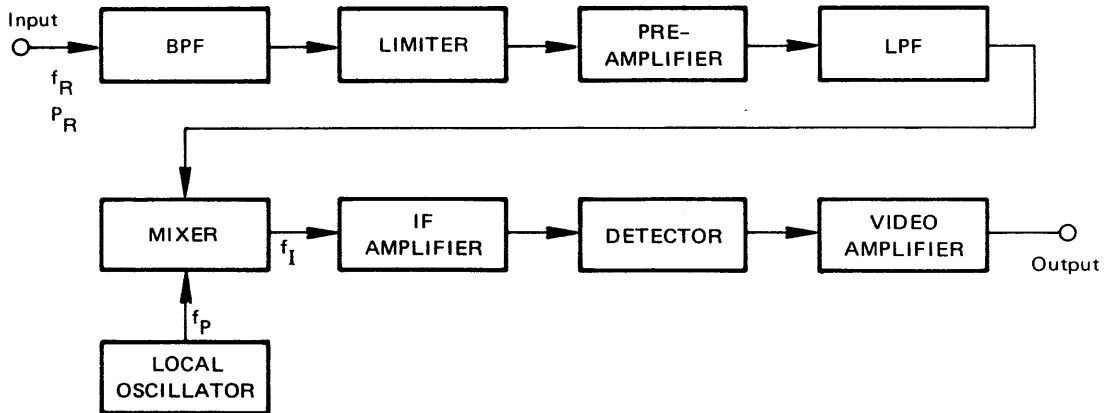

SA-1970-5

FIGURE IV-3 COMPLEX AM RECEIVER CONCEPT

2. Diode Detector

An ideal diode detector, when operating as a square-law device, converts a peak-power RF waveform to a peak-voltage waveform without degradation of the pulse waveform. In actual diode-detector circuits, it is feasible to obtain a peak-voltage waveform without degradation only if the bandwidths of the video filter and IF amplifier are broad enough to cover the frequency spread of $\sin X/X$ in the frequency domain of the input pulsed RF signal. The wider the bandwidth of the video filter, the less tangential sensitivity of the diode detector is expected, thus limiting the usefulness of the diode detector. It should also be noted that even though the tangential sensitivity of a detector will increase with reduced bandwidth, the pulse waveform shape will be distorted and a less fundamental pulse output will exist; a tradeoff occurs between the two parameters.

Video detectors make the simplest type of receiver front end. They are used in three closely related applications:

- Direct RF input demodulation
- IF detectors after mixer conversion
- Power monitors.

They are most useful for circuits where broad bandwidth, simplicity, size, and weight are prime requirements.

In diode detectors there are two types of noise – white noise (shot noise plus thermal), which is primarily due to thermal conditions, and flicker noise, which has a relationship with the modulating signal frequency. At low modulating signal frequencies of 10 Hz to 100 Hz, diodes have noise-temperature ratios of 40 to 50 dB.

The noise ratio of diodes due to flicker noise is represented by B_x/f , where B_x is an arbitrary constant for different diodes and contains the dimension of frequency, and may be regarded as a fictitious bandwidth characteristic of the diode. The total noise ratio of diodes is generally written as $t = tw + B_x/f$, with $tw = 1$ at zero bias. (For Schottky diodes, tw is approximately equal to 1, even with bias.)

Noise for diode detection followed by an IF amplifier with gain G can be represented by the following equation:²⁻⁴

$$\frac{N}{G} = kTB tw + kTB_x 1n \left(\frac{f_h}{f_l} \right) + kT_o B (F_v - 1)$$

Bandwidth B is equal to $f_h - f_l$. (IV-2)

Diode performance can be described by two common terms – tangential signal sensitivity (TSS), and nominal detectable signal (NDS). TSS is a direct measurement of signal-to-noise voltage in a detector receiver. The measurement is carried out with a pulse signal, the level of which is adjusted so that the highest noise peaks observed on an oscilloscope in the absence of a signal are at the same level as the lowest noise peaks in the presence of the signal. The signal level thus determined gives the TSS value. TSS corresponds to an SNR of approximately 2.5/1. Although the measurement is subjective and depends on the operator, it is most commonly used.

The nominal detectable signal (NDS) is defined as the exact microwave power required to produce an output power equal to noise power.

NDS is calculated as follows. The ratio of output signal power from the IF amplifier to the output noise power N is

$$\frac{\text{Signal}}{\text{Noise}} = G \frac{\langle S_v \rangle^2}{4R_v} \cdot \frac{1}{N} \quad (\text{IV-3})$$

where $\langle S_v \rangle^2/4R_v$ is the available signal power from the diode and G is the gain

$$\langle S_v \rangle = \gamma P$$

where γ is the voltage sensitivity in volts/watts, and P is the input power to the diode and R_v = diode impedance.

To calculate NDS we can set the output SNR equal to unity and replace P by NDS. Therefore,

$$\text{NDS} = \frac{2}{\gamma} \sqrt{R_v \frac{N}{G}} \quad (\text{IV-4})$$

Substituting for N/G (defined earlier),

$$\text{NDS} = \frac{2}{\gamma} \sqrt{kTR_v \left[Btw + \frac{T_o}{T} (F_v - 1)B + B_x \ell_n \left(\frac{f_h}{f_l} \right) \right]} \quad (\text{IV-5})$$

where

- k = Boltzman constant
- T = Absolute temperature
- T_o = Room temperature
- tw = White-noise temperature ratio
- F_v = Noise figure of video amplifier.

The TSS is found empirically to be 4 dB above NDS under ordinary conditions. The various parameters TSS and NDS are all dependent on the amplifier bandwidth, usually varying as the square root of the bandwidth. Thus the value at which measurements are made must be quoted in specifying the detector. The usual value is a 2-MHz video bandwidth.

Data sheets on commercially available diode detectors were studied. Results are summarized in Table IV-3. It can be seen in this table that the best Schottky-barrier diode (MA-40215) has a TSS of -48 dBm at 16 GHz. This corresponds to an SNR of 4 dB with a video bandwidth of 10 MHz. By use of Eq. (IV-4) for a 100-MHz bandwidth, the TSS value would be -43 dBm. In order to satisfy the system requirement of the beacon receiver, the probability of detection has to be 0.95, which corresponds to an SNR of 13.8 dB. Therefore the RF signal strength level has to be -33 dBm at the input to the diode-detector receiver. For lower values of signal levels than -33 dBm at 16 GHz, diode detectors cannot be used, and mixers should be considered.

Table IV-3. Commercial Detector Diodes

| Diode Type | Manufacturer | Model No. | Test Frequency (GHz) | TSS*† (dBm) |
|------------------|--------------|-----------|----------------------|-------------|
| Schottky Barrier | MA† | MA-40207 | 10 | -52 |
| Schottky Barrier | MA | MA-40215 | 16 | -48 |
| Schottky Barrier | Alpha | D5754A | 10 | -50 |
| Schottky Barrier | Alpha | D5236 | 10 | -53 |
| Point Contact | Alpha | D4194A | 16 | -51 |
| Point Contact | Alpha | D4195A | 24 | -51 |
| Point Contact | Alpha | D4196A | 35 | -48 |
| Point Contact | MA | MA-4116 | 16 | -51 |
| Point Contact | MA | MA-452B | 10 | -52 |

*Video Bandwidth = 10 MHz.

†Bias = 50 μ A.

‡Microwave Associates.

3. Mixer Concepts

The sensitivity of a microwave receiver can be greatly increased by using the heterodyne principle, which can avoid the 1/f noise problems. The received signal is first mixed with a local-oscillator signal in a nonlinear resistance (diode) circuit to derive a difference signal or intermediate-frequency signal that can be easily amplified before it is detected. The intermediate frequency is set at a value above the 1/f region of the diode noise spectrum. It is amplified by an IF amplifier and then detected using a diode detector.

Receiver sensitivity is described as "noise figure" and is defined as the ratio of the rms output noise power of the receiver to that of a hypothetical receiver of the same gain and bandwidth whose input noise power is equal to the thermal-agitation noise power developed across its input impedance.

The overall noise figure is specified on most mixer types. With a suitable gas-tube noise source, the overall noise figure can be measured. At present, a calculated value of noise figure may be used for some military applications. The calculation is based on individual measurements of conversion loss and noise ratio and an assumed IF amplifier noise. The overall noise figure is given by the following formula:

$$NF \text{ (dB)} = L_c + 10 \log_{10} (NF_{IF} + N_r - 1) \quad \text{(IV-6)}$$

where

L_c = Conversion loss of the diode (dB)

NF_{IF} = IF amplifier noise figure (expressed as a ratio)

NR or t_w = Noise ratio of the diode (ratio).

The parenthetic expression $(NF_{IF} + N_r - 1)$ as expressed in ratio form may be converted to dB and then added directly to the conversion loss in decibels.

As seen in the above formula, the overall performance of the microwave receiver can be predicted from knowledge of the diode characteristics and the noise generated in the IF amplifier (assuming that the gain is sufficient to amplify this noise to the detection level). For example, if

$$L_c = 8.5 \text{ dB}, N_r = 1, \text{ and } NF_{IF} = 1.5 \text{ dB},$$

then the noise figure of the receiver is 10 dB. Therefore, for a 100-MHz-bandwidth receiver, the equivalent thermal noise at the input to the receiver would (given by $KTBF$) be -84 dBm. For an SNR equal to 13.8 dB, the minimum signal strength must be -70.2 dBm. This is clearly more sensitive than a diode-detector receiver.

Noise-figure comparisons for different state-of-the-art diodes are covered in Section VI-C.

There are various mixer designs, depending on the RF frequency and IF bandwidth required. The four popular types of mixers for low-noise front-end designs are:

- Single-ended mixer
- Single-balanced mixer
- Double-balanced mixer
- Image-reject mixer.

a. Single-Ended Mixer

The single-ended mixer consists of a coupler (the amount of coupling depends on the LO power level), a diode, and circuitry that filters the IF output from the appropriate port. This type of mixer does not offer any local-oscillator AM noise cancellation. Neither does it offer reduction in currents due to intermodulation products of the local-oscillator signal and RF signal. It does require a large local-oscillator power drive, which is not required in the other schemes.

b. Single-Balanced Mixer

The single-balanced mixer consists of a 3-dB coupler, two diodes, and circuitry to filter the IF out of the appropriate port. It offers the lowest noise figure and low input VSWR. With a quadrature hybrid, bandwidths up to a decade are possible. The phase relationships in a quadrature coupler lead to low LO-to-RF isolation; 6 dB is typical. By using a rat-race or "magic-tee" hybrid, high LO-to-RF isolation (20 dB typical) can be achieved. These hybrids in distributed constant form are limited to narrow bands, an octave being the upper limit. The lumped-constant equivalent, wound on a ferrite core, can cover many octaves. With a single-balanced mixer, the IF must be below the RF and LO frequencies. By means of filtering, however, very high IFs can be utilized. Another important feature of the single-balanced mixer is LO noise cancellation. This is dependent on the hybrid isolation, the diode match, and the load presented at the mixer RF port. Using a quadrature hybrid, 10 to 15 dB of cancellation is possible. With a rat-race hybrid, this increases an additional 5 to 10 dB. In addition, even-order intermodulation products can be suppressed.

c. Double-Balanced Mixer

The double-balanced mixer consists of two center-tapped 3-dB in-phase hybrids or transformers that are joined together with a circuit consisting of four diodes in either a bridge or a ring

form. The LO signal is fed to the primary of one transformer while the RF signal is fed to the primary of the other transformer. The symmetry of the mixer, rather than filtering, isolates the IF from the other frequencies; therefore, the IF, RF, and LO bands may overlap. This symmetry tends to suppress even-order and odd-order intermodulation products (2 X 2, 3 X 3, etc.). Both of these properties are dependent on the actual construction and vary considerably between different models.

The main advantages of a double-balanced mixer, as compared with a single-balanced mixer, are higher LO-to-RF isolation (20 to 30 dB, depending on the operating frequency), higher LO noise suppression, suppression of even or odd intermodulation products, and no IF filtering. The main disadvantages of a double-balanced mixer, as compared with a single-balanced mixer, are high input VSWR, higher conversion loss, higher LO power drive and incompatibility with microstrip or stripline techniques.

d. Image-Reject Mixer

The image-reject mixer incorporates a pair of balanced mixers (single-balanced or double-balanced), two RF hybrid and one IF hybrid. The RF is fed through a quadrature hybrid while the LO is fed through an equal-phase power divider. The IF outputs are combined in an IF quadrature hybrid. The response due to the upper sideband appears at one output port of the IF hybrid, while the response due to the lower sideband appears at the other. Therefore the image band noise generated in a microwave preamplifier is then suppressed. Also, this type of mixer gives an automatic cancellation of spurious image signals that may appear at the real IF output without the use of RF bandpass filters at the RF port.

Since either single- or double-balanced mixers can be used in the design of an image-reject mixer, their respective advantages and disadvantages are the same as those of single-balanced and double-balanced mixers discussed above.

4. Transmitter Concepts

There are chiefly four types of transmitter concepts applicable to beacon transponders. These concepts are shown diagrammatically in Figure IV-4. One block common to these various schemes is that of a microwave source or OSC. Designs of microwave source or OSC will be discussed separately. The detector circuit shown in Figures IV-(c) and IV-(d) is considered as part of the transponder receiver. The transmitter concepts are compared in Table IV-4.

Transmitters in Figures IV-4(a) and (b) are instantaneous types, while those in Figures IV-4(c) and (d) are delay types. The ideal transmitter design goals are to use a system that has minimum circuits, high efficiencies, conserves dc power, has no delay, has no expensive state-of-the-art solid-state devices, and does not depend on breakthroughs in technology. The system in Figure IV-4(c) satisfies all the goals except the one concerning delay. We considered this system for detailed design and breadboard at Ku-band. Results and details are discussed in the next section. At this point, let us consider the advantages and disadvantages of each scheme first.

The transmitter system in Figure IV-4(a) uses an upper-sideband upconverter. The solid-state device used is a varactor diode. Efficiency of 50% at X-band at 10 watts CW output can be achieved. At higher frequencies, efficiency will drop somewhat. If f_i , the intermediate frequency, is low (compared to the pump frequency f_p), then overall efficiency is the product of the efficiency of the microwave power source or OSC and the upconverter. Therefore at an upconverter efficiency of 50%, the overall efficiency will be one-half that of the microwave power source. This is the main disadvantage. Another disadvantage

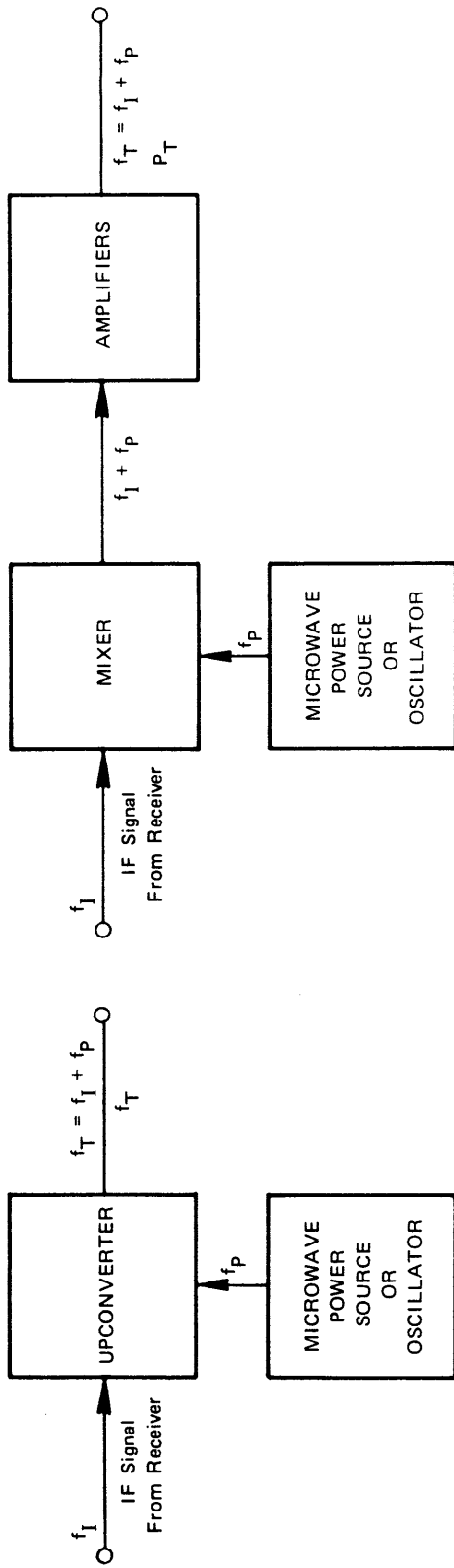

(a) TRANSMITTER USING HIGH-POWER UPCONVERTER

(b) TRANSMITTER USING MIXER AND AMPLIFIERS

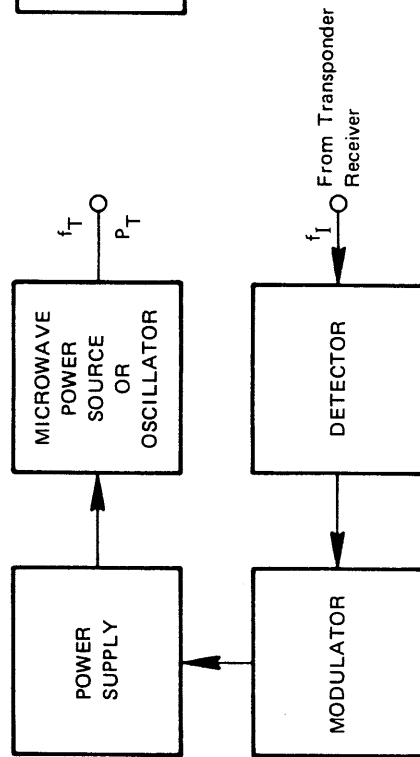

(c) TRANSMITTER USING MICROWAVE POWER SOURCE AND MODULATED POWER SUPPLY

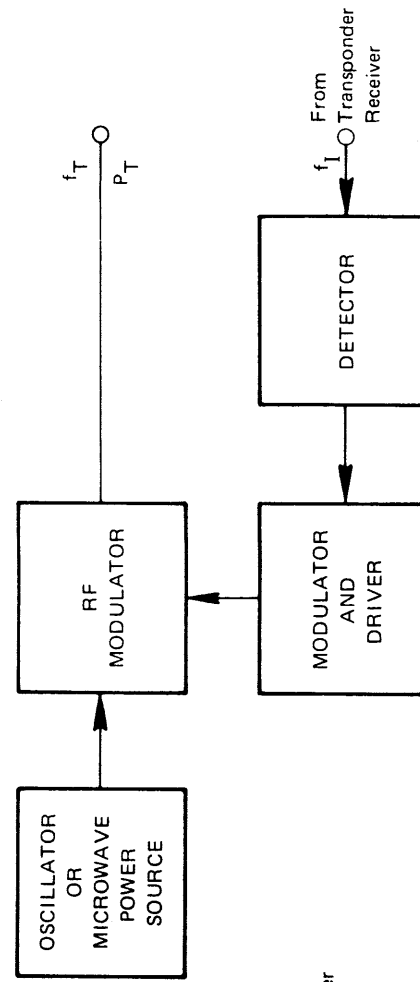

(d) TRANSMITTER USING MICROWAVE POWER SOURCE AND RF MODULATOR

FIGURE IV-4 SIMPLE AM TRANSMITTER CONCEPTS FOR TRANSPONDERS

Table IV-4. Comparison of AM Transmitters for Beacon Application

| Important Design Parameters | System of Figure IV(a) | System of Figure IV(b) | System of Figure IV(c) | System of Figure IV(d) |
|--|------------------------|---|------------------------|------------------------|
| No. of different circuits of sub-systems | 2 | 3 | 2 | 3 |
| Efficiency | Fair | Good | Excellent | Very Good |
| Conservation of dc power | No | Yes for Class C Operation No for Direct Generation | Yes | No |
| Instantaneous or delay | Instantaneous | Instantaneous | Delay | Delay |
| No. of expensive active solid-state devices used | 2 | 2 | 1 | 2 |
| Cost | Medium | High | Low | Medium |

is that Varactor diodes have the same limitations as the direct-generation diodes, which are mainly heat dissipation and transfer in heat sinks. The system in Figure IV-4(a) should be considered primarily for instantaneous-type transponders. However, such beacon transponders could be designed so that the dc power supplies are turned ON once only when the ASD radar illuminates the beacon. This would involve a delay period, and some information would be lost during the period when the oscillator is in transient stage. Timing circuits could be incorporated to automatically turn the transmitter OFF after a set period of operation.

The transmitter system in Figure IV-4(b) uses an upper-sideband down-converter (modulator) that is pumped at a high frequency by the microwave source or OSC. The output signal from the mixer is the sum of the pump frequency and the IF signal frequency. To drive the downconverter, low-power RF signal is required from the microwave source, which is an advantage. For low conversion loss (6 dB to 10 dB) 10 mW CW power would be sufficient. The sum signal is then amplified to a high power level. Class C transistor amplifiers could be used for frequencies up to 4.5 GHz so that dc power is conserved. For frequencies greater than 4.5 GHz, transistors are not available; therefore, direct-generation devices such as IMPATT, TRAPATT, or Gunn can be used. With the present state of technology, these devices require constant dc current at all times for operation as oscillators or amplifiers; hence dc power cannot be conserved.

The system in Figure IV-4(b) has one main advantage over the one in Figure IV-4(a). Only one high-power circuit is used instead of two and the efficiency is twice as much. This simplifies the overall heat-sinking problems.

The transmitter system in Figure IV-4(c) is a delay type. The power supplies are turned on and applied to the microwave source only when the transponder beacon is illuminated by the ASD radar. DC

power is used only when ASD radar is illuminated. A special pulse-modulator design is required to turn the power supplies on and off. Also power supplies should be designed so that switching occurs at fast rise times. Preliminary investigation shows that fast-switching power supplies can be achieved with cost-effective transistor and logic circuitry for production models. However, detailed designs need to be performed.

The advantage of the system in Figure IV-4(c) over that in IV-4(b) is that the dc power supplies are conserved with the system efficiency approximately the same. It should be pointed out that direct-generation oscillators generally have more efficiency than amplifiers. Also, the oscillator designs are simpler. Therefore the system in Figure IV-4(c) has favorable characteristics.

The transmitter system in Figure IV-4(d) is a delay type. It uses an RF modulator instead of the dc power-supply modulator used in Figure IV-4(c). It is expected that this type of system will have a faster response time than that considered in Figure IV-4(c). No dc power is conserved since the microwave source is on continuously. Attenuation is provided by the RF modulator. The efficiency expected is lower than that of Figure IV-4(c) because of additional insertion loss expected in the modulator.

After considering the four systems, it appears that the systems in Figures IV-4(b) and IV-4(c) are the best for production versions of the transmitter. However, we recommend using the system in Figure IV-4(c) primarily because of low cost, excellent efficiency, and conservation of dc power.

Microwave power-source concepts are shown in Figure IV-5. Frequency stability, frequency of operation, and output power level will determine the type of system to use. At frequencies up to 4 GHz transistor oscillators and amplifiers can be used. If stringent frequency stability is required, crystal control sources will have to be used. Such a system is shown in Figure IV-5(a). The number of doublers or multipliers used would depend on the frequency output and power level. However, it appears that such a concept will not be cost effective because of the number of components used.

The free-running oscillator and amplifier combination or the single-oscillator scheme [Figure IV-5(b) or IV-5(c)] are cost-effective techniques and ideal for low-cost beacon transponder applications. If the ASD radar receiver IF bandwidth is large, stringent constraints need not be specified on the stability of the oscillators.

F. CONCLUSIONS

1. Recommendations Concerning the Type of Mixer Receiver for Low-Cost Beacon Transponder

It appears from the investigations of different types of mixers that a single-balanced mixer is ideal for low-cost beacon receivers. For cost-effective purposes, single-balanced mixer designs offer adequate performance for the least number of components. In addition, single-balanced mixers can be fabricated easily using micro-strip or stripline techniques when produced in production quantities.

2. Recommendations Concerning the Type of Transmitter Concept for Low-Cost Beacon Transponder

The system shown in Figure IV-4(c) is recommended for utilization in low-cost, high-efficiency beacon transponders if the fixed delay period through the transmitter can be compensated at the radar station and if requirements of frequency stability at the radar receiver are not severe. It is expected that the ASD radars will have a large IF bandwidth to compensate for a slight drift of the beacon transmitter. To achieve low cost, weight, and volume, we recommend using a simple transmitter in the beacon transponder and complex receiver circuitry in the ASD radars.

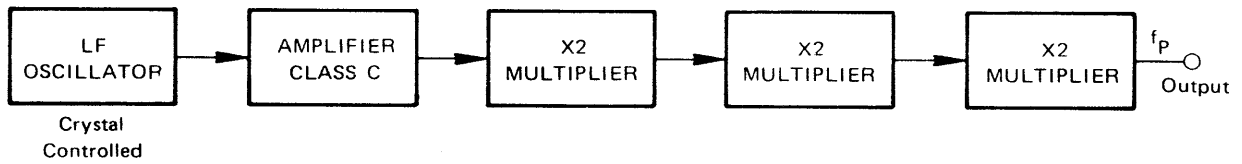

(a) CRYSTAL-CONTROLLED OSCILLATOR/VARACTOR MULTIPLIER COMBINATION

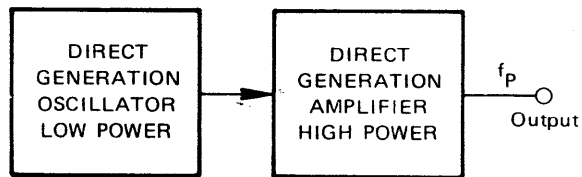

(b) DIRECT-GENERATION OSCILLATOR/AMPLIFIER COMBINATION

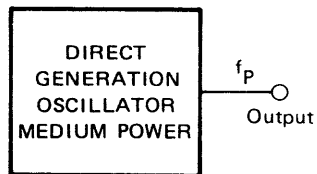

(c) DIRECT GENERATION OSCILLATOR

SA-1970-6

FIGURE IV-5 MICROWAVE-POWER SOURCE CONCEPTS

REFERENCES FOR SECTION IV

1. B. Kramer, "A 22% CW Efficiency Solid State Microwave Oscillator," paper presented at 1972 *International Microwave Symposium*, Illinois.
2. A. Uhlir, Jr., "Characterization of Crystal Diodes for Low Level Microwave Detection," *The Microwave Journal* (July 1963).
3. H.C. Torrey and C.A. Whitmer, *Crystal Rectifiers*, (McGraw-Hill Book Co., New York, N.Y., 1948).
4. G.R. Nicoll, "Noise in Silicon Microwave Diodes," *Proc. IEEE*, Part 3, Vol. 101, pp. 317-324 (September 1954).

V. KU-BAND COOPERATIVE-BEACON-TRANSPONDER DEVELOPMENT

A. GENERAL

A beacon-transponder scheme was selected for development and breadboard fabrication based on the theoretical conceptual designs and goals discussed in Section IV. The objective of this development was to show the feasibility of a low-cost, all-solid-state cooperative beacon transponder that could be used for target-enhancement purposes for a range of 5 miles in conjunction with an existing ASD radar.

After careful consideration of the type and performance specification of the beacon transponder, it was decided to develop a system that would be compatible with the 4.5-dB NF ASD (T.I.) radar, and similar in performance to the transmitting system discussed in Section IV [refer to Figure IV-4(c) and Table IV-4 for details]. RF power output requirements for the beacon transponder are 3.3 watts maximum for a range of 5 miles and 16 mm/hr of rain (worst case) with system probability of detection of 0.95. One double-drift IMPATT diode oscillator circuit could satisfy this power requirement. Beacon-transponder receiver sensitivity requirements are also low for the ASD (T.I.) radar. Sensitivities of -46.7 dBm and -36.3 dBm are required for a range of 5 miles, 16 mm/hr of rainfall and clear weather, respectively (see Table IV-2 for the calculations). In order to maintain an SNR ratio of 13.8 dB and probability of detection of 0.95, the noise level must be -60.5 dBm for 16 mm/hr rainfall and -50.1 dBm for clear weather. To achieve the sensitivity for 5 mile range and 16 mm/hr rainfall (worst case), a mixer pumped with a local oscillator is necessary. Again, since the objectives here are to show the basic principles of the beacon-transponder design concepts, a receiver was developed using a diode detector with a lower sensitivity, -43 dBm tangential sensitivity, SNR = 4 dB, and video bandwidth of 100 MHz (for calculations see IV-E-2.). It is recommended that the more advanced mixer type of receiver be considered in other future developments and for the production model of a beacon transponder.

One reason for selecting an ASD (T.I.) radar for a beacon transponder application was that a development radar system at 14.5 GHz is presently being field-tested at Los Angeles International Airport (LAX). During the planning stages it was thought that the breadboard beacon transponder developed on this program could be field tested in the future on other contracts. Comparison of the performance of active target-enhancement techniques with the performance of corner-reflector could be made.

In the following sections, design details of all the components in the beacon transponder developed at 14.5 GHz are shown and discussed.

B. CONCEPTUAL DESIGN

A block diagram of a solid-state cooperative beacon transponder is shown in Figure V-1. The important features of this design are:

- One antenna system is utilized, simplifying the antenna design. Transmitter and receiver are combined via a circulator or diplexer. A circulator was selected for ease in fabrication; however, for production models a diplexer will be used.

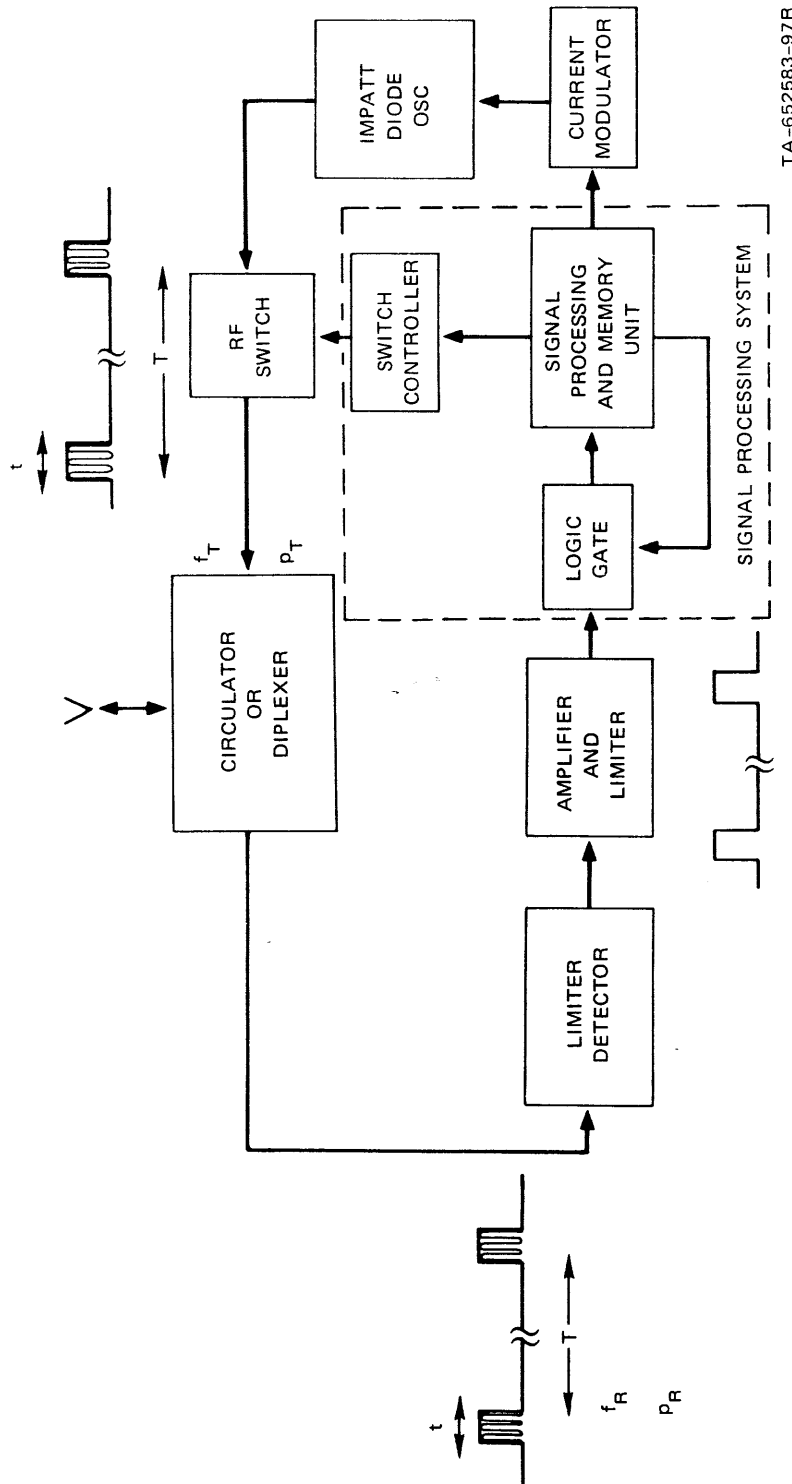

TA-652583-97R

FIGURE V-1 BLOCK DIAGRAM OF COOPERATIVE SIGNAL-PROCESSING BEACON TRANSPONDER

- All-solid-state design
 - A high-power IMPATT diode oscillator is used in the transmitter.
 - A detector or a mixer pumped with a Gunn diode oscillator can be used in the receiver. For low cost and limited range (2.5 miles) in clear weather, a detector is used with SNR of 13.8 dB. For 5 mile range or more and 16 mm/hr of rain with SNR ratio of 13.8 dB, a mixer scheme can be used in the receiver for additional sensitivity. In our transponder a detector was selected for ease of design.
 - A high-gain video amplifier with limiting capability is used to amplify the detected pulses. In the limiting mode the amplifier was designed to minimize pulse envelope distortion for any false triggering of the logic gate. Such a limiting scheme allows the utilization of the beacon transponder at close and far range from the ASD radar.
- The design of the various components in the system allows the use of microwave integrated circuits and hybrid integrated-circuit techniques. Such techniques are useful for large production at low cost.
- Low-cost digital techniques are applied for processing, gating, isolation between receiver and transmitter, and pulse shaping instead of analog techniques. Digital techniques are used where size, volume, and uniformity in circuit design are necessary.
- Input received pulsed RF signals and output transmitted pulsed RF signals in the transponder are synchronized without any change in repetition rate, pulsewidth, or duty cycle in the envelope. This is important for the airport surface-detection (ASD) or surveillance radars where distances or identification of the location is obtained from the envelope and delay-time information of the various signals received at the radar. Delay through the transponder is constant and can be taken into consideration in the radar processing and memory unit.
- An RF switch is operated in time sequence after the IMPATT diode oscillator is operating in a steady-state condition. This control is maintained by the memory logic. This design adaptation is useful because rise and fall times of the output pulsed RF signal from the transponder are strictly dependent on the RF switch operation. A state-of-the-art fast RF switch is superior to the design of the fast pulsed IMPATT diode oscillators. To obtain fast rise times, an IMPATT diode oscillator and voltage- and current-shaping networks are necessary in the pulse drivers. The matching network of the IMPATT diode oscillator depends on the pulse duration and repetition rate that cause thermal heating of the diode junction. To overcome such problems, we have avoided using high-accuracy and sophisticated drivers for the IMPATT diode oscillator. To conserve in the dc power consumption, the IMPATT diode oscillator is also pulsed at the same repetition rate but with a much larger pulsewidth. The RF switch operates after the IMPATT diode has settled down to a steady-state condition. The only disadvantage of the RF switch is in the extra insertion loss, which decreases the overall efficiency of the system. In production-type models, the switch can be eliminated and IMPATT diode oscillators with current shaping networks can be used.

C. DETAILED DESIGN

1. IMPATT Diode Oscillator

a. General

Various designs of IMPATT diode oscillators were investigated for application in the beacon transponders at Ku-band (14.5 GHz). Two different designs were selected as being most applicable for the beacon-transponder breadboard. These are a low-Q coaxial, fixed-tuned IMPATT diode circuit and a high-Q waveguide fixed-tuned IMPATT diode circuit.

Low-Q oscillators have their primary use in applications where the frequency stability and noise characteristics of the diode can be controlled by injection phase-locking techniques. However, for the breadboard beacon transponder we considered, no injection locking techniques were applied primarily because our goals were to design low-cost circuits. The realization of a low-Q (10 to 30), fixed-tuned IMPATT oscillator is a straightforward matter. The most important design requirement is proper transformation of the transmission-line impedance of 50 ohms down to the required load impedance for optimum diode performance as an oscillator. There are a number of techniques that can be used to do this. The two simplest techniques are the use of a quarter-wave transformer with characteristic impedance $Z_t < 50$ ohms and the use of a shunt capacitor C_L in front of the diode.

As a second possibility for the beacon-transponder oscillator, a high-Q, waveguide fixed-tuned IMPATT diode circuit was considered. Two different high-Q circuit designs were investigated. One design consisted basically of a coaxial oscillator that is strongly coupled to a high-Q waveguide resonator. The waveguide resonator is in turn coupled by an iris to the load. Mechanical construction and diode-matching techniques are complex as compared to the low-Q coaxial circuit design. The second design of a high-Q IMPATT diode that was investigated consisted of a rectangular waveguide shorted at one end and with a diode inserted in the center at $\lambda_g/2$ cm away from the short. This oscillator concept, because of its simplicity, is well suited to applications where cost is an important factor. However, the disadvantages are that the design principles for this oscillator are less well known than for the low-Q coaxial oscillators. Also, the matching networks at the diode terminals are somewhat complex.

It was determined that the low-Q coaxial, fixed-tuned IMPATT diode circuit should be used for the breadboard beacon transponder because there are more test data and design techniques available and also because our designs could lend themselves to microstrip or stripline fabrication techniques for production units. In addition, the diode parameters have been specified in this type of circuit by the commercial manufacturer.

A simple IMPATT oscillator circuit is shown in Figure V-2. Basic oscillator theory states that oscillation will occur if, at some frequency, the total load impedance connected to the IMPATT diode is the negative of the diode impedance. The efficiency and power from the oscillator depend greatly on the selection of the diode and the matching network.

b. Equivalent Circuit of IMPATT Diode Chip

An equivalent circuit for the IMPATT diode chip can be described simply as a series resistance R_D in series with a capacitive reactance X_D . Included in R_D is the unavoidable parasitic series resistance R_S , contributed by the contacts and the undepleted portion of the N region. There are four important properties in an IMPATT diode equivalent circuit that must be considered in the oscillator design. First, the magnitude of the net negative resistance R_D is usually much smaller than that of X_D , the reactance. Consequently, the magnitude of the chip impedance is approximately X_D . Second, for most cases of

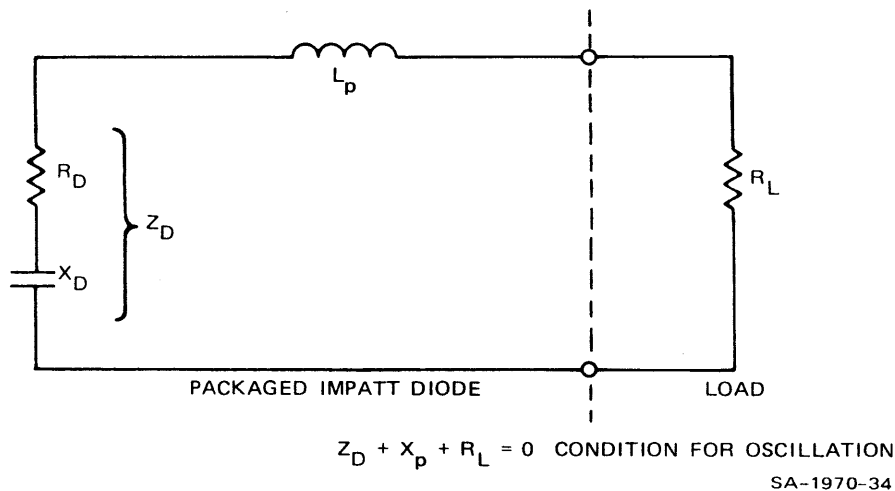

FIGURE V-2 SIMPLE IMPATT DIODE OSCILLATOR CIRCUIT

interest, X_D can be approximated with sufficient accuracy by the reactance of the junction (chip) capacitance at the breakdown voltage. This capacitance is denoted by $C_j(V_b)$, where V_b is the reverse voltage. C_j can be measured and used in the matching network design. Third, values of the net negative resistance are generally small compared to the circuit transmission-line impedances. Typical values are in the vicinity of several ohms. This puts a great constraint on the mechanical tolerances and contact resistance specification in the circuits before the diode. Therefore, fabrication techniques have to be controlled for repeatable results in different circuits. The fourth property is the behavior of the IMPATT diode negative resistance with signal level. The magnitude of R_D varies with the drive signal level. In fact, it decreases with increasing drive signal level. In addition to the variation with signal level the magnitude of R_D also varies with dc bias current and junction temperature. Therefore, to maintain stable oscillation, the relationship in the oscillator circuit, $Z_D + X_p + R_L = 0$, must be satisfied at all times. Since the chip is mostly capacitive, the external load must be inductive; the real part of the load resistance must be in the range of several ohms, and more specifically must be less than the maximum value of $|R_D|$. If these conditions are satisfied, oscillations will build up in the circuit at a frequency for which $X_D = -X_L$. The oscillations will continue to build up until $R_L + R_D = 0$; this is a stable operating point.

c. Packaged Diode Equivalent Circuit

The diode chip equivalent circuit is considerably modified by the presence of the varactor package parasitic reactances. Up to now, we have been discussing the properties of the chip itself, but in microwave circuit design the entire packaged diode must be considered. To a good approximation, the package can be described by two reactive elements — a series inductance, and a shunt capacitance.

The complete packaged IMPATT diode equivalent circuit is shown in Figure V-3. The exact values of L_p and C_p vary somewhat from one package style to another. Typical values for the Hewlett-Packard Style 46 package end-mounted in 7-mm coax are 0.3 nH and 0.4 pF, respectively. The value of L_p is affected drastically by the microwave circuit surrounding the diode — this fact can be used to tune an oscillator.

d. Selection of IMPATT Diode

Different types of Ku-band IMPATT diodes were considered for the oscillator designs. A number of diode manufacturers were contacted to discuss the availability and test data on high-power pulsed

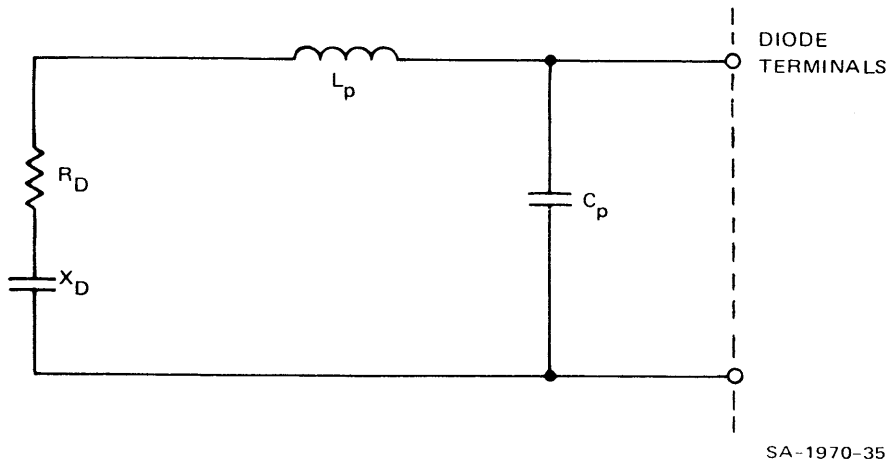

FIGURE V-3 IMPATT DIODE PACKAGE EQUIVALENT CIRCUIT

IMPATT diodes. The diode manufacturers contacted were Raytheon Co., Waltham, Mass.; Microwave Associates, Burlington, Mass.; and HPA Labs., Palo Alto, Calif. The IMPATT diodes that we have selected are double-drift type made by Hewlett-Packard (Part No. 5082-0757, Package 46). Double-drift IMPATT diodes are capable of providing high peak pulse power at maximum efficiency. The HP 5082-0757 diode was designed for optimum performance at 16 GHz. It was determined that this diode operating in a similar circuit at 14.5 GHz would experience a degradation in efficiency to 5% and the peak power output would drop to 5 watts. Inquiry was made concerning the availability of double-drift diodes fabricated for optimum performance at 14.5 GHz with performance characteristics similar to those of the 16 GHz diodes. HP indicated that none were available but that they could be fabricated. However, the development costs were prohibitive and the delivery schedules were not acceptable for this contract. Therefore, it was decided to use the 16-GHz diodes in a 14.5-GHz circuit and accept the degradation in performance. This particular diode provides 7 to 8 watts peak power, a pulsewidth of 800 ns, and a duty cycle of 25% at 16 GHz with an efficiency of 10%. The dc pulse voltage required at 14.5 GHz is expected to be 80 to 100 volts maximum. This, therefore, set the upper limit in the dc voltage required from the pulse. The diode package was selected such that the parasitics are low and the self-resonance frequency is above the operating frequency.

e. Low-Q Coaxial Fixed-Tuned IMPATT Diode Oscillator

A circuit schematic of a low-Q coaxial fixed-tuned IMPATT diode oscillator is shown in Figure V-4. It consists of an isolator, a bias tee, a matching transformer, and an IMPATT diode. The isolator is inserted in the output circuit to prevent the diode from burning out if the output load is suddenly disconnected in the presence of dc currents to the diode. The bias tee is required to block the dc current from the output load and to apply dc current and pulsed voltage signals to the diode. The matching transformer is used to match the 50-ohm output load to the diode impedance, which is generally of the order of 4 to 6 ohms at 14.5 GHz. This oscillator will oscillate at a fixed-tuned frequency determined by the overall microwave circuitry of the matching network, the diode impedances, and any other parasitics due to the mechanical assembly or cavity around the diode. Such a circuit configuration could be fabricated by using either coaxial or MIC techniques. Since diode impedances for the coaxial circuits were available from HP, we decided to fabricate a low-Q coaxial oscillator in a 7-mm line. However, for low-cost production units, MIC techniques are applicable and are recommended.

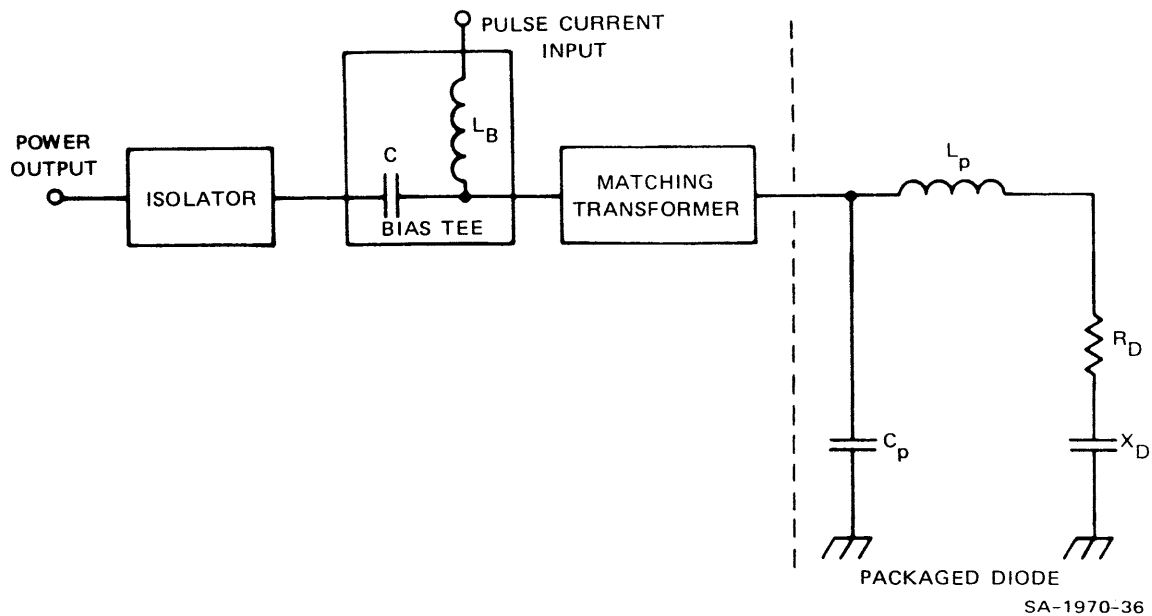
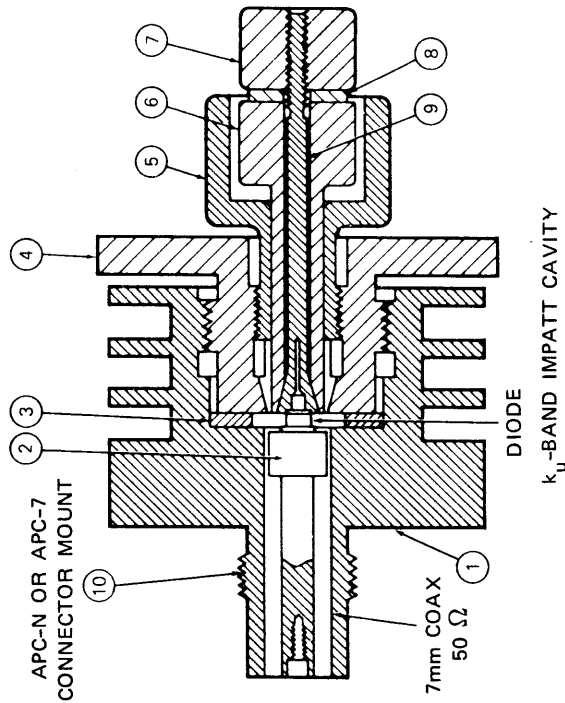

FIGURE V-4 CIRCUIT SCHEMATIC OF LOW-Q COAXIAL FIXED-TUNED IMPATT DIODE OSCILLATOR

Fabrication of the oscillator circuit was based on the information supplied by HP concerning their 16-GHz oscillator and on the details shown in HP applications note 935. Different transformers with varying lengths and diameters, collets and spacers were fabricated so the oscillator performance at the required frequency can be maximized. The inductance L_p varies depending on the dimension of the cavity that is around it. By varying the recess in the collet of the diode holder, an inductance can be varied from 0.3 nH at zero recess to 0.17 nH for a recess of 20 miles.

A number of ways of mounting the diode in the microwave circuit were investigated. Figure V-5 shows a structure provides a good heat-flow path to a heat sink and low-resistance electrical contacts. The collet-clamp-sleeve arrangement is suitable for end-mounting diodes in coaxial circuits and provides a low-cost breadboard where quick interchangeability of diodes is desirable. The diode holder assembly was designed to consist of a diode collet for gripping the heat-sink end of the diode, a sleeve into which the diode collet is inserted, a knurled nut that pulls the collet tightly into the sleeve, and a clamp.

Designs of the bias tee and the isolator were investigated also. These are standard designs and are commercially available. The bias tee was of particular interest because relaxation or spurious oscillations can occur at much lower frequencies in the bias circuit if the impedance of the bias circuit as seen by the diode is low at the spurious frequency. A bias tee was selected that had low VSWR (1.3 maximum) and insertion loss (0.3 dB maximum) at the RF ports and high cutoff frequency (8 GHz) at the bias port to pass pulse voltages to the IMPATT diode without degradation. Therefore, low-capacitance reactances to ground were avoided at the bias port. The isolator was selected to have low VSWR (≤ 1.3 maximum) and low insertion loss (0.5 dB maximum), and medium isolation of 20 dB minimum at the operating frequency. The output power from the oscillator is expected to be lower because of the losses in the bias circuit and the isolator.



| PARTS LIST | | | MANUFACTURER'S PART NO. |
|------------|----------------|------------------|-------------------------------|
| ITEM | DESCRIPTION | MATERIAL | |
| 1 | CAVITY BODY | TeCu (Alloy 145) | AMPHENOL #131-1050 (APC-7) |
| 2 | TRANSFORMER | TeCu (Alloy 145) | |
| 3 | SPACER | BRASS | |
| 4 | NUT | TeCu (Alloy 145) | |
| 5 | CLAMP | TeCu (Alloy 145) | |
| 6 | SLEEVE | TeCu (Alloy 145) | |
| 7 | NUT | STEEL | |
| 8 | WASHER | NO. 4 | |
| 9 | COLLET | TeCu (Alloy 145) | |
| 10 | CONNECTOR ASSY | | |

SA-1970-19

FIGURE V-5 14.5-GHz IMPATT DIODE OSCILLATOR ASSEMBLY

2. Diode-Detector Receiver Design

The breadboard receiver consisted of a diode detector and a pulse amplifier followed by a logic gate circuit. The maximum range at which the breadboard beacon transponder can be placed from a radar with characteristics equivalent to those of the ASD (T.I.) radar depends on the maximum receiver sensitivity. The sensitivity of the receiver depends on the tangential sensitivity of the detector. Therefore, a review of available detectors was made.

a. Selection of Diode Detector

A tunnel diode detector Model No. DOM 208F made by Aertech, 825 Stewart Drive, Sunnyvale, California was selected for the breadboard beacon receiver. The tunnel diode detector selected is matched over a broad bandwidth without resistive loading. This provides excellent sensitivity and flat response. The dynamic video resistance of the diode is in the order of 100 ohms and is very suitable for wideband video signals. Some of the other chief advantages of the tunnel diode detector include temperature stability and wide dynamic range.

The specifications for Aertech Model No. DOM 208F are as follows:

- Frequency range: 12–18 GHz
- Open-circuit voltage sensitivity (K): 400 mV/mW
- Figure of Merit

$$\left(M = \frac{K}{\sqrt{R_V}} \right) : 40$$

where

R_V = Video resistance of detector,
in ohms

- Flatness: ± 0.5 dB
- Input VSWR: 2.0
- Video capacitance (C_V): 7 pF
- Video Bandwidth

$$\left(\frac{1}{2\pi RC_V} \text{ where } R = 50 \text{ ohms} \right) : 400 \text{ MHz}$$

- Tangential sensitivity: -48 dBm (Min)

$$\left[\begin{array}{l} \text{Video amplifier N}\cdot\text{F} = 2 \text{ dB} \\ \text{Video bandwidth} = 2 \text{ MHz} \end{array} \right].$$

In the following paragraphs, results of calculations based on the characteristics of the above detector are reported for the breadboard beacon receiver sensitivity, detector loss, pulse amplifier gain, and range. It is assumed that the system probability of detection at the beacon receiver is 0.95, which corresponds to an SNR of 13.8 dB, and the radar characteristics are equivalent to those of ASD (T.I.) radar.

b. Sensitivity

The tangential sensitivity of -48 dBm for the Aertech tunnel diode detector Model 208F is for a video bandwidth of 2 MHz and video amplifier noise figure of 2 dB. The actual TSS of the tunnel diode detector in the breadboard beacon receiver will be decreased to -38.5 dBm because the video bandwidth necessary to maintain the detected pulse shape is 50 MHz and the noise figure of the pulse amplifier following the diode detector is 7 dB. To maintain a system SNR of 13.8 dB with the Aertech diode detector, the minimum detectable signal will be -28.7 dBm ($S = -4 + 13.8 - 38.5 = -28.7$). Therefore, the maximum target range will be equal to 2.25 miles in clear weather and 1.55 miles in 16 mm/hr of rain for the ASD radar (4.5 dB NF).

c. Detector Loss

The open-circuit voltage sensitivity of the Aertech Model No. DOM 208F tunnel diode detector is 400 mV/mW. When the detector video output has a load of 50 ohms the sensitivity drops to 100 mV/mW. Peak power to the detector is 1 mW, the output peak power in a load of 50 ohms will be 0.2 mW. This is equivalent to a loss of 7 dB. In practice the loss is in the range of 6 dB to 10 dB, depending on the power input to the detector.

d. Pulse-Amplifier Gain

Assuming that the tunnel diode detector loss is 10 dB (worst case), the minimum signal expected at the output of the detector is -38.7 dBm. A pulse amplifier whose gain is 41 dB from dc to 50 MHz is required. This gain is sufficient to provide a minimum peak signal output of 0.4 volts into 50 ohms load, and is necessary to drive the logic gate. Different companies were contacted regarding a video amplifier that could meet our specification. Avantek, Inc. (Santa Clara, CA) amplifier Model No. AV-3 or AV-5; and Amplica Inc. (Westlake Village, CA) amplifier Model No. 201-USU are comparable in performance and cost. These amplifiers have a gain of 30 dB and a video bandwidth of 250 MHz. To satisfy our requirements, two such amplifiers will be cascaded with a low-pass filter of 50 MHz bandwidth. A fixed 10-dB pad will be added between the amplifiers to reduce the overall cascaded amplifier gain.

The required dynamic operating range of the cascaded amplifiers depends on the minimum distance between the beacon transponder and the ASD radar. For purposes of calculation, assume that the minimum distance between the beacon transponder and the radar will be 1/10 mile, which corresponds to a signal level of -2 dBm at the beacon receiver. Thus, the dynamic range at the input to the diode detector is -28.7 dBm to -2 dBm = 26.7 dB. If the loss of the detector is constant (10 dB maximum) over the input signal power range to the detector, then the detected output range will be -12 dBm (maximum) to -38.7 dBm (minimum). At an input peak power of -12 dBm, the second amplifier stage may saturate and distort the pulse. Therefore, a diode limiter will be connected at the output of the first amplifier stage to limit the input drive. The limiter will consist of a parallel-connected hot carrier diode to ground.

3. Signal-Processing Systems

The functions of the signal-processing unit shown in the block diagram of the proposed bread-board beacon transponder (Figure V-1) are:

- Instantaneously operate a gate on a pulse-to-pulse basis at the output of the beacon receiver. The gate will be open at all times except when the IMPATT diode oscillator is turned ON. Also, the gate will be closed for any time period when there are overshoots or ringing due to the video amplifiers. Amplifiers may be saturated when high leakage signals from the oscillator are present. In addition, the gate will operate at the same rate and duration as the received signals.
- Instantaneously operate the current modulator that drives the IMPATT diode oscillator after the first pulse is received. The pulse duration will be fixed and repeated at the same rate and duration as the input received signal.
- Store permanently preset information regarding the pulsewidth of the radar system, the delay period required to operate the RF switch, and the time sequence for operating the logic gate after the oscillator is turned off.
- Operate the RF switch at the output of the oscillator after a fixed delay.

To meet the above system requirements of the beacon transponder, various digital logic schemes for signal processing were investigated. A final scheme that was accepted for fabrication and testing is shown in Figure V-6. The truth table that describes the logical operation of the gate is also shown in this figure. The main pulse-train waveform that would exist in the processing system is shown in Figure V-7. The horizontal time scale shown in the figure was arbitrarily selected for design convenience. However, the design requirements of 450 ns pulsewidth for the current modulator is essential for achieving high efficiency from the IMPATT diode oscillator circuit. Any reduction would also reduce the power.

The important design features that were incorporated in the signal processing are:

- All circuits are T²L logic compatible including the comparator.
- Threshold level at the input to the comparator can be adjusted to any value for sensitivity until the SNR approaches unity.
- Fast rise and fall time capability of 10 ns. This requirement is essential for the ASD radar processor, which uses delay-time and rise-time information for range calculation.
- Low-cost-circuitry design.
- Reliable and temperature-insensitive.
- Low power-drain requirements.

4. Current Modulator for the IMPATT Diode Oscillator

The proposed beacon transponder requires a T²L logic compatible pulsed bias supply to the IMPATT diode oscillator. A review of the different types of pulsers was made. The IMPATT diode oscillator requires a constant-current dc bias source. There exists a fairly complicated interaction between the RF and bias port impedances of an IMPATT diode and under certain conditions oscillations in the bias circuit are possible. These can be avoided by proper bias circuit design.

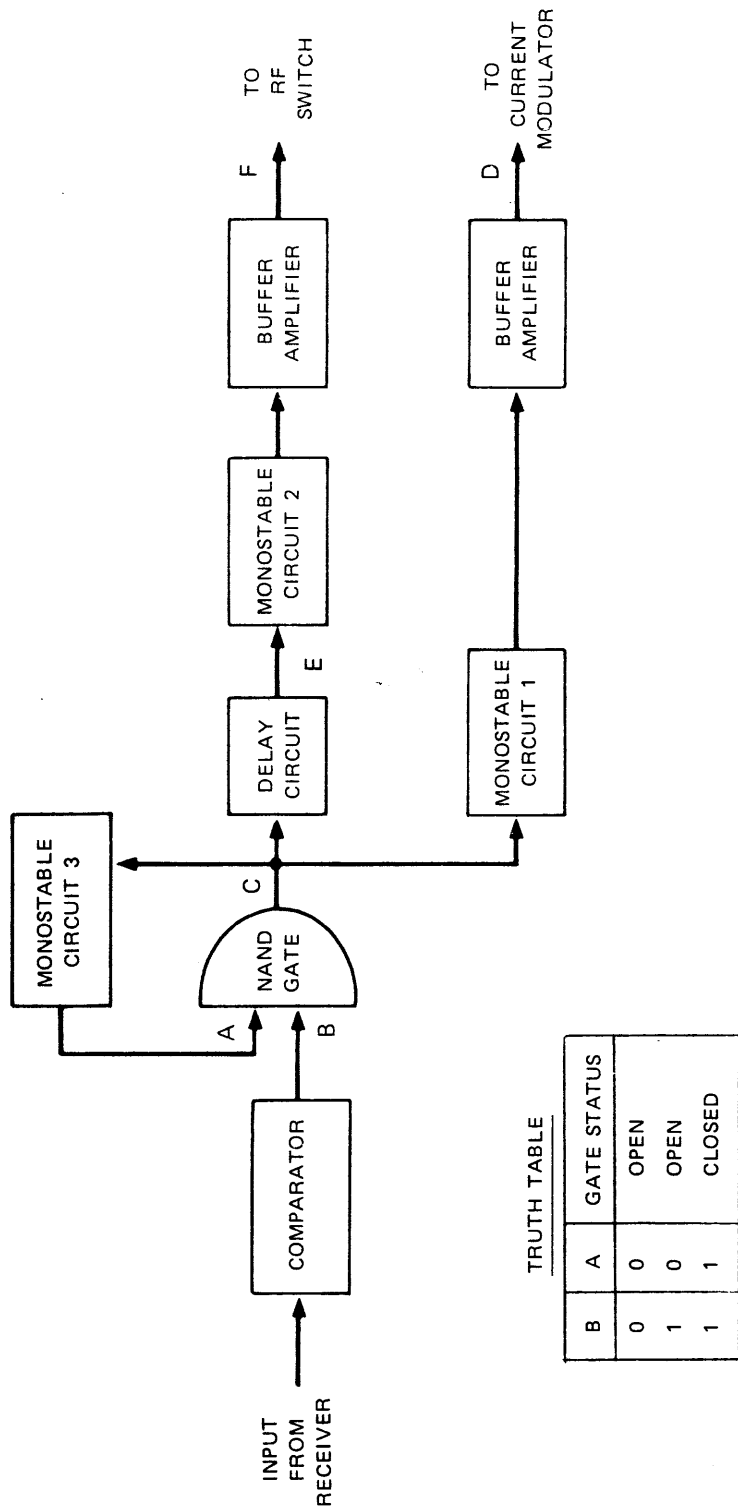

SA-1970-37

FIGURE V-6 BLOCK DIAGRAM OF SIGNAL-PROCESSING SYSTEM

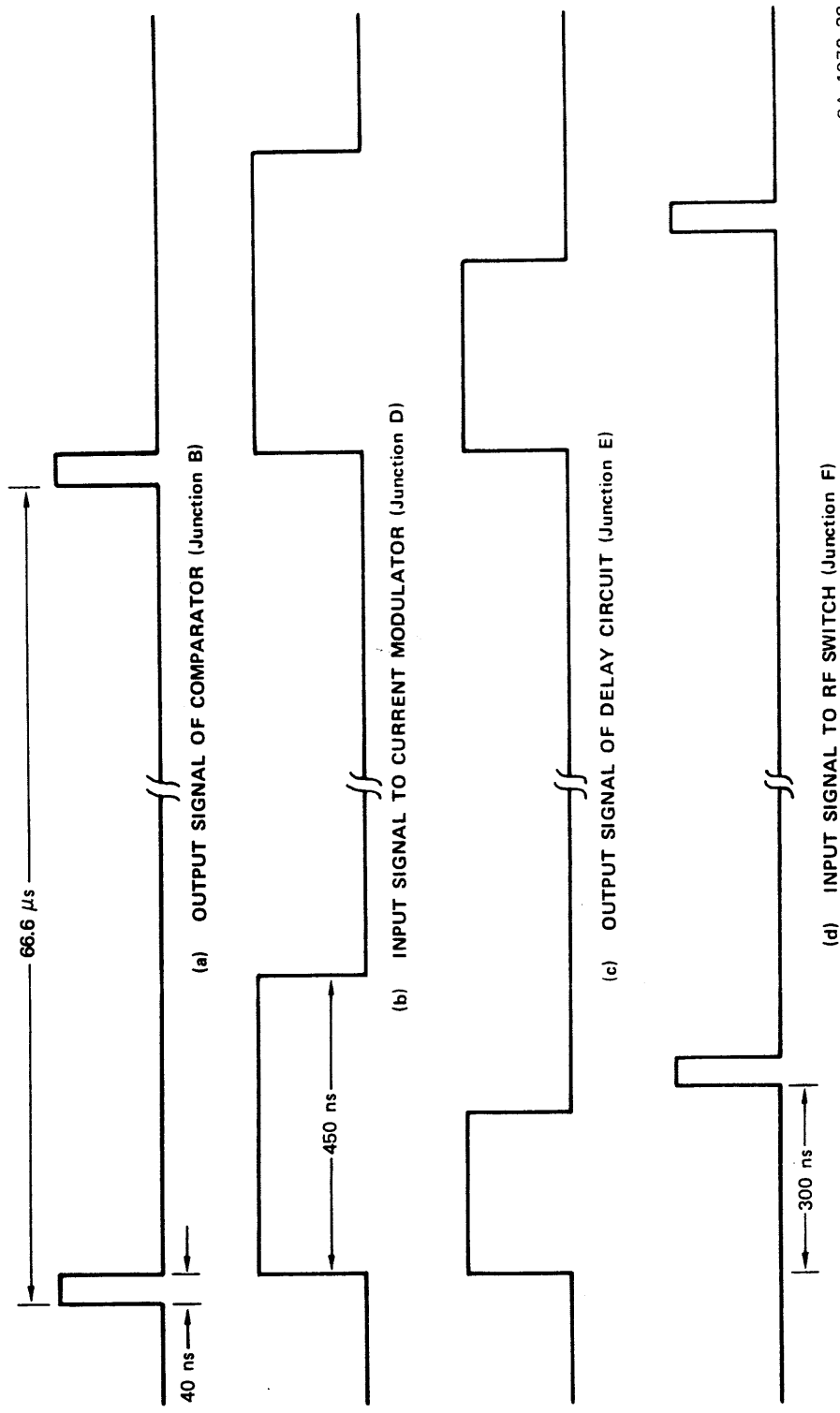

SA-1970-38

FIGURE V-7 MAIN PULSE-TRAIN WAVEFORMS IN THE SIGNAL-PROCESSING SYSTEM

A transistorized design of a constant-current dc bias source was selected that avoids bias-circuit oscillations. The bias network was designed with a fixed bias of 60 volts and a variable pulse voltage of 20 to 40 volts in series. A schematic of the network is shown in Figure V-8.

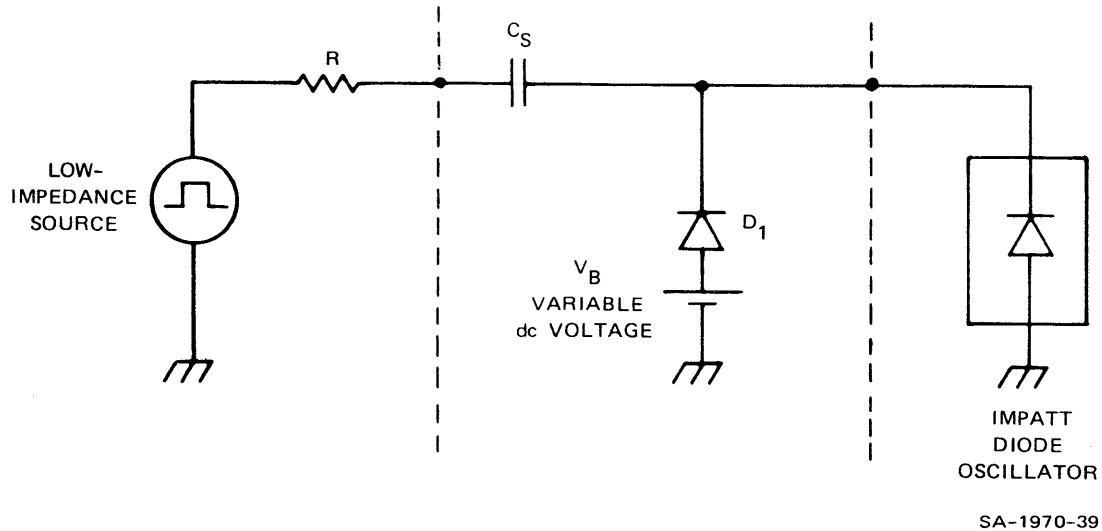

FIGURE V-8 PULSE-ADDING BIAS CIRCUIT FOR IMPATT DIODE OSCILLATOR

D. FABRICATED AND PURCHASED PARTS

1. IMPATT Diode Oscillator

The basic parts of the low-Q coaxial IMPATT diode oscillator were fabricated out of tellurium copper alloy No. 145. Tellurium copper (TeCu) was selected as the base material because it has better heat conductivity than beryllium copper and is easy to machine. The complete disassembled oscillator is shown in Figure V-9 and an assembled unit is shown in Figure V-10. A parts list of the assembly and materials used in the manufacturing process is shown in Figure V-5.*

The diode package selected for the oscillator design was HP No. 46. Readers interested in the mechanical details and diode parasitics can obtain the information by referring to the HP Diode and Transistor Designers Catalog, September 1972. This particular package offers very low parasitic values and has a high heat conductivity.

2. Diode Detector Receiver

A standard off-the-shelf tunnel diode detector Model No. DOM 208F was purchased from Aertech, 825 Stewart Drive, Sunnyvale, California for use as the receiver detector diode.

*See also Hewlett Packard application note 935.

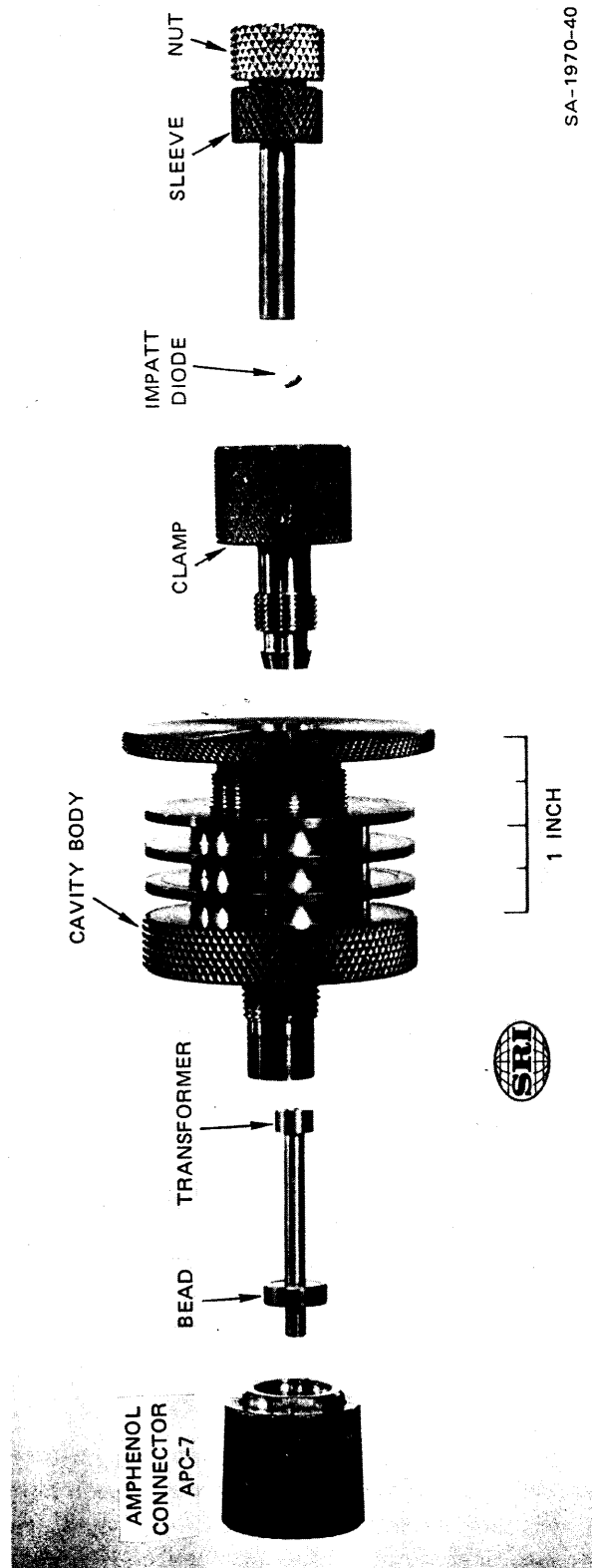
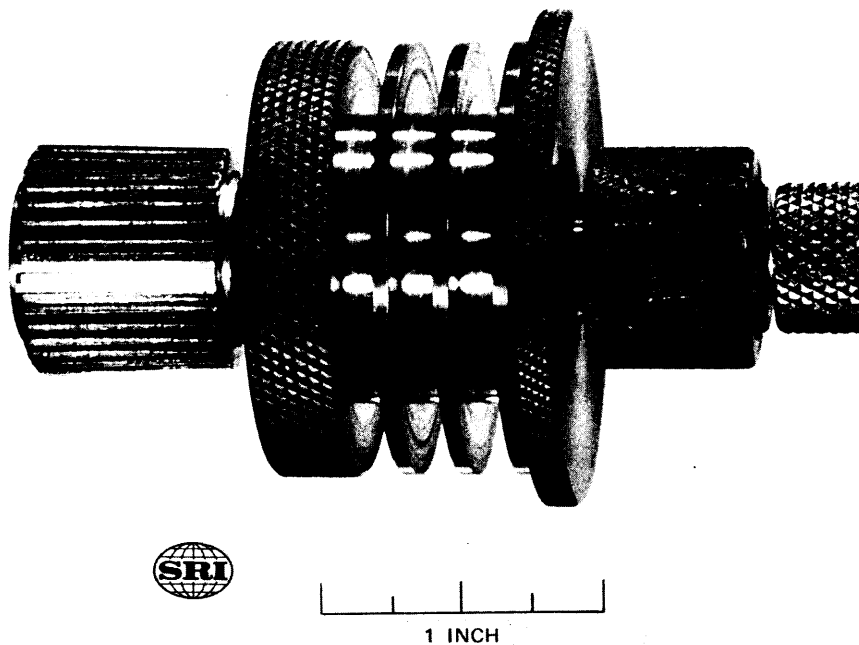

FIGURE V-9 DISASSEMBLED KU-BAND IMPATT DIODE OSCILLATOR



SA-1970-41

FIGURE V-10 ASSEMBLED Ku-BAND IMPATT DIODE OSCILLATOR

The pulse amplifier that follows the RF detector was designed to SRI's specifications by Amplica Inc., Westlake Village, California. Measured data on this unit are as follows (Amplica Amplifier Model No. 8331 US, Serial No. 101):

- Pulse gain: 32 dB typical
- Noise figure: 5 dB typical
- Overshoot and ringing
 - leading edge of pulse 4%
 - trailing edge of pulse 80% (approximately)
- Rise time: 1.5 ns
- Droop: < 1% for 1 μ s pulse
- Peak-to-peak pulse output: 3 volts
- Supply voltage: +15 volts dc @ 45 mA

3. Signal-Processing System

A signal-processing system was constructed to meet the design requirements discussed in Section V-C of this section. A circuit schematic of the processing system is shown in Figure V-11. Standard off-the-shelf integrated logic circuits were used and fabricated on an insulating board. Well-known manufacturing techniques and practices were used for the layout of the circuit and interconnections. Each integrated circuit was properly biased, connected, and utilized according to the manufacturers specification.

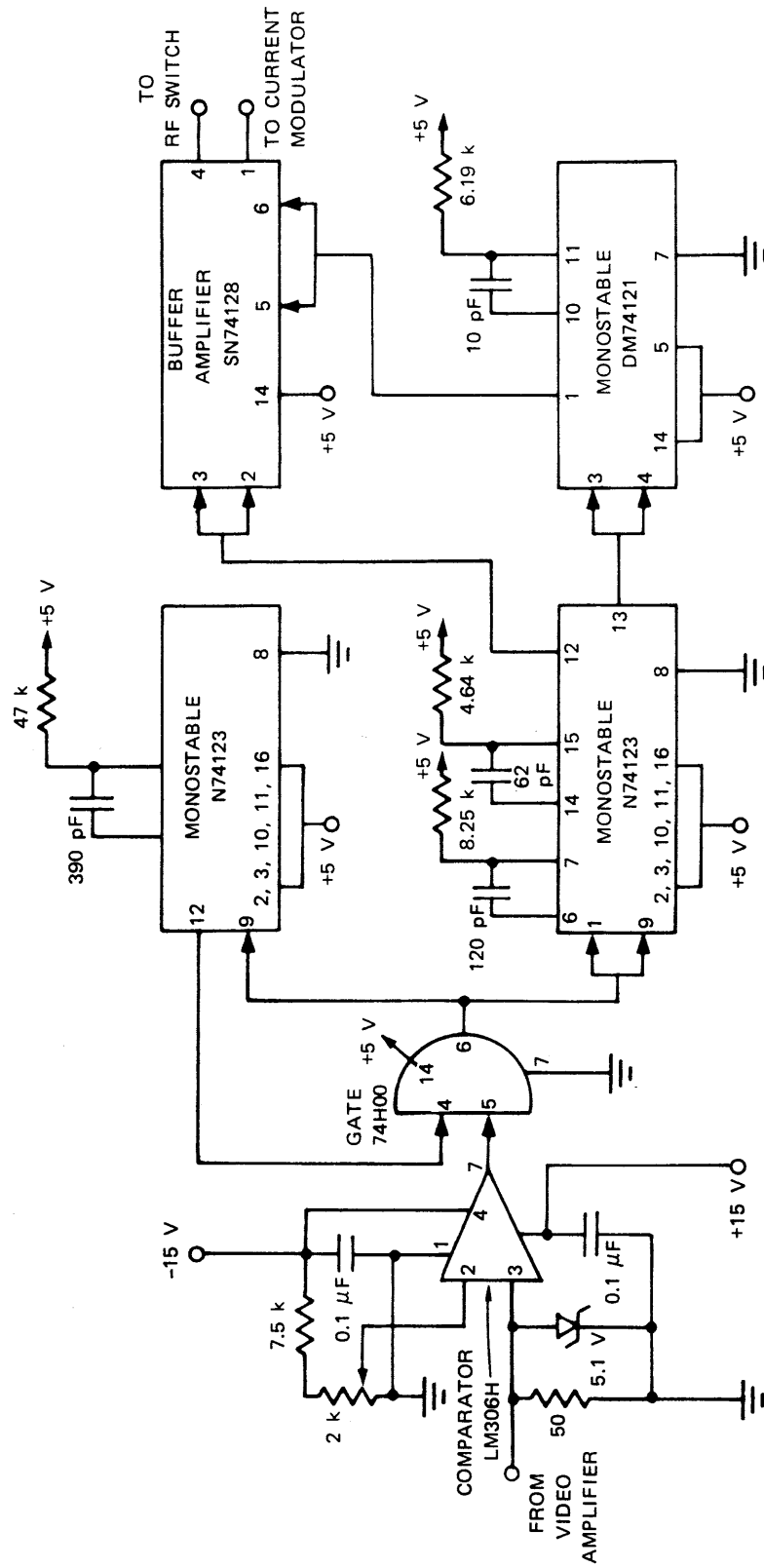

SA-1970-42

FIGURE V-11 CIRCUIT SCHEMATIC OF SIGNAL-PROCESSING SYSTEM

4. Current Modulator for the IMPATT Diode Oscillator

Details of the current modulator circuit are given in Figure V-12. A maximum constant current of 1 amp can be supplied by the pulse modulator to the IMPATT diode circuit. Low pulse voltages (0–30 volts) are added to the high dc bias voltage required by the IMPATT diode. The output-pulse voltage across a load can be varied by a control voltage at the input. Control voltage is varied from 0 to -10 volts. Low-voltage transistors and components are used in the constant-current pulse circuit. The pulse circuit is T²L logic compatible and fast rise and fall times are possible without degradation.

5. RF Switch

A T²L logic compatible RF switch (Model No. DM862AH) that satisfied the breadboard beacon-transponder design requirements was purchased from General Microwave Corporation, Farmingdale, New York. It has low insertion loss, low VSWR, and fast switching response capability. The characteristics of the switch are as follows:

- Frequency responses 0.2–18 GHz
- Minimum isolation (dB) 45 dB at 12–18 GHz
 $I_F = 20 \text{ mA}$
- Maximum insertion loss (dB) 2.3 dB
 $V_R = -10 \text{ V}$
- Maximum VSWR (ON position) 2.2:1
- Switching speed 10 ns
ON to OFF
OFF to ON
- Voltage requirements +15 V at 45 mA
-15 V at 15 mA

6. Integration

After all the components mentioned in Sections V-D-1 through 5 were individually fabricated and fully tested, an integrated assembly of the breadboard beacon transponder (Figure V-13) was built according to the conceptual circuit design shown in Figure V-1. The IMPATT diode oscillator and the diode detector receiver were connected via a low-loss (0.5 dB maximum) circulator (No. I-35-1450) purchased from Wavecom Industries, Sunnyvale, California. An isolator was connected between the IMPATT diode oscillator and the RF switch to protect the IMPATT diode from burnout when the switch is in the open-circuit mode. The mechanical configuration of the complete breadboard beacon transponder in a box is shown in Figure V-14. No attempts were made to reduce size in the fabrication process or in the layout of the components. The object was to get a working compact breadboard model to demonstrate the performance of the system.

E. TEST RESULTS AND DATA

A semiautomatic test setup was designed and assembled to allow simultaneous observation of all the critical test parameters of the RF components and logic circuits in the breadboard beacon transponder. In addition, the same test setup can be used to characterize the integrated breadboard beacon transponder. A

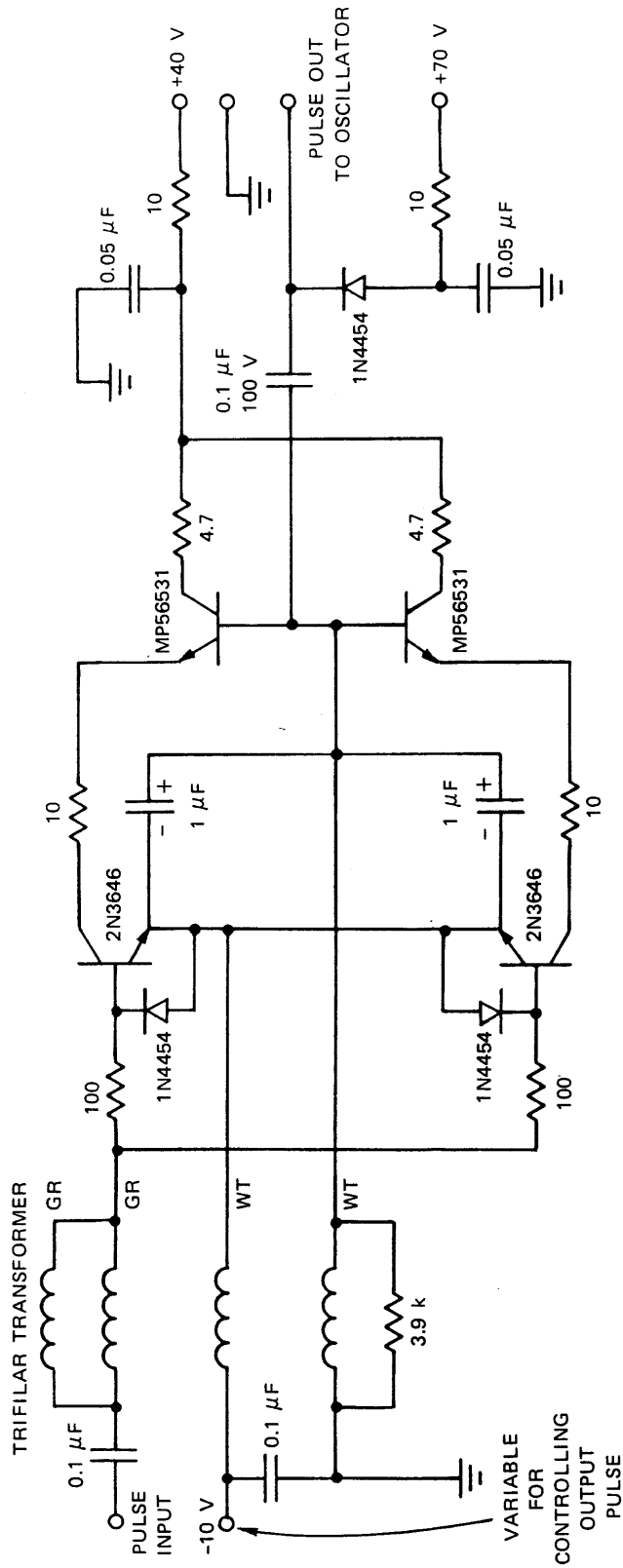

SA-1970-43

FIGURE V-12 CIRCUIT SCHEMATIC OF CURRENT MODULATOR FOR THE IMPATT DIODE OSCILLATOR
(Courtesy of A. Podell)

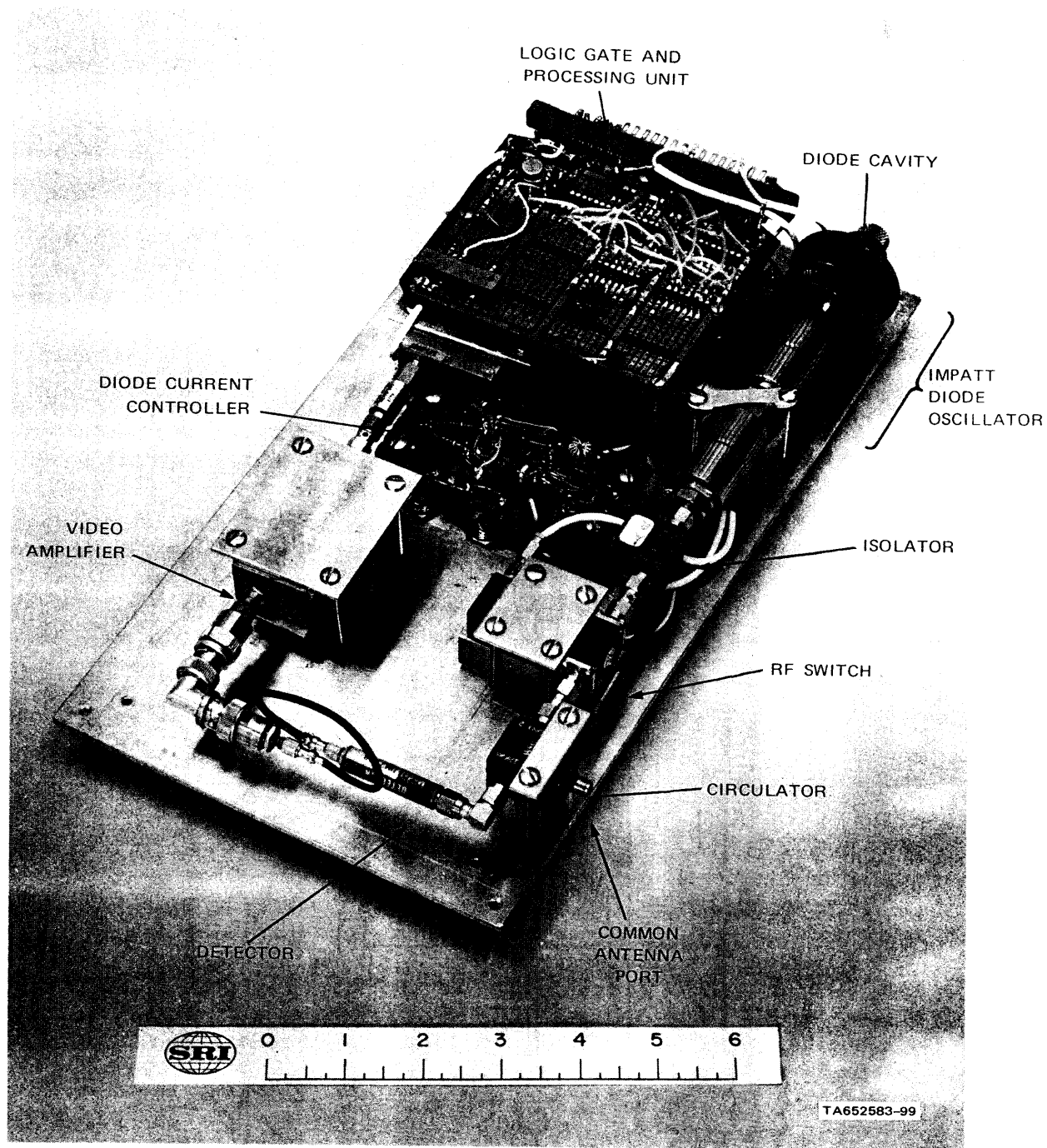

FIGURE V-13 14.5-GHz SOLID-STATE COOPERATIVE BEACON TRANSPONDER FOR AIRPORT SURFACE DETECTION (ASD) RADAR

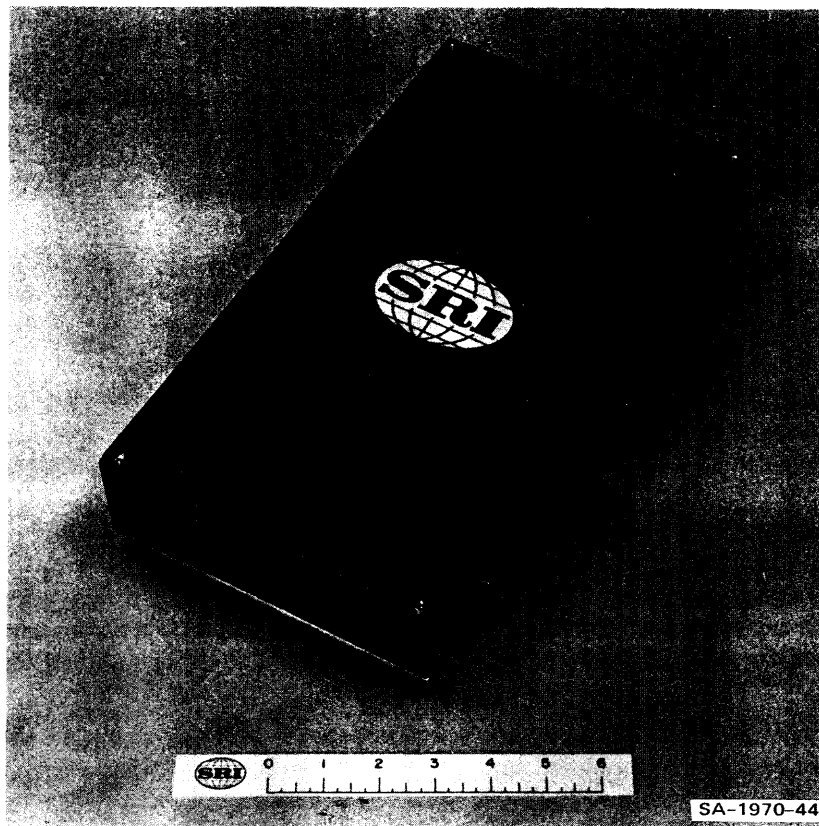

FIGURE V-14 BREADBOARD BEACON TRANSPONDER IN A BOX

photograph of the test setup is shown in Figure V-15 and a detailed schematic in Figure V-16. The unique feature of the test setup is that the pulsed RF signals to the beacon transponder simulate actual ASD radar signals. The pulsewidth, pulse rate, RF frequency, and power levels of the signals to the transponder can be observed, analyzed, and compared with the input signals to the transponder. This type of flexible measuring capability offers a means of performing controlled experiments to evaluate and characterize a unit under test with meaningful results.

Prior to performing tests on the beacon transponder, the overall test setup was calibrated and correction tables were made. All measured data were then modified, taking the system errors into consideration. Tests were initially performed on all the individual components in the transponder.

The results of all the important measurements that characterize the breadboard beacon transponder are shown in Figures V-17 through V-23. The content of these figures is summarized in the following:

- Figure V-17 shows a frequency spectrum of the pulsed RF output from the beacon transponder. This response was observed on the HP network analyzer. The nulls shown in the figure are sharp and the envelope is very close to the $(\sin x/x)$ representation.
- Figure V-18 shows the detected envelope of the RF input to the beacon transponder. The slight distortion in the envelope was due to the pulse generator driving the RF signal generator.
- Figure V-19 shows the detected envelope of the RF output from the beacon transponder. The rise and fall times are 10 ns. The pulsewidth of the output pulse is different from that of the input pulse; however, adjustment can be made to the logic circuit to decrease the pulsewidth of the output pulse to 40 ns.

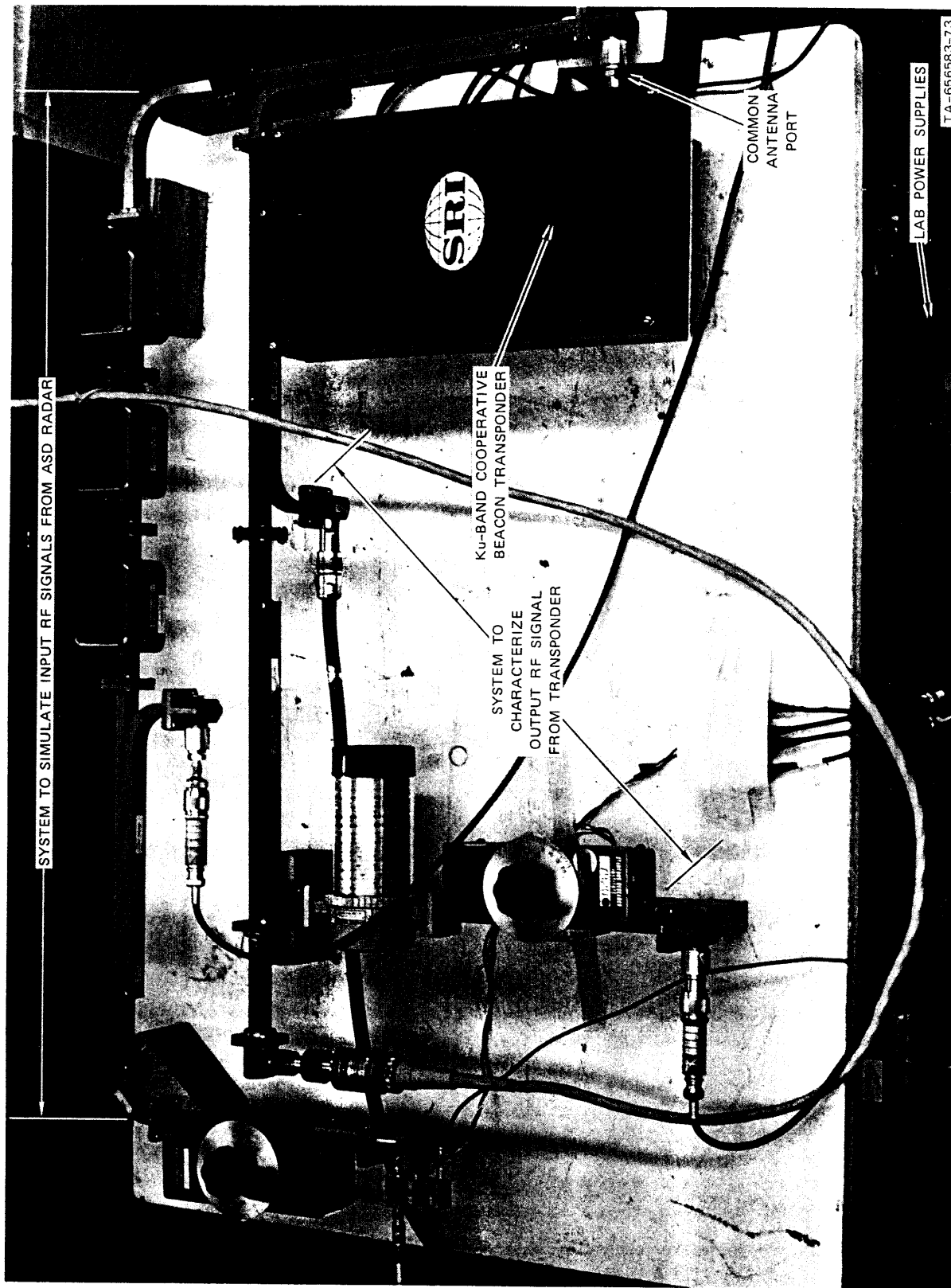
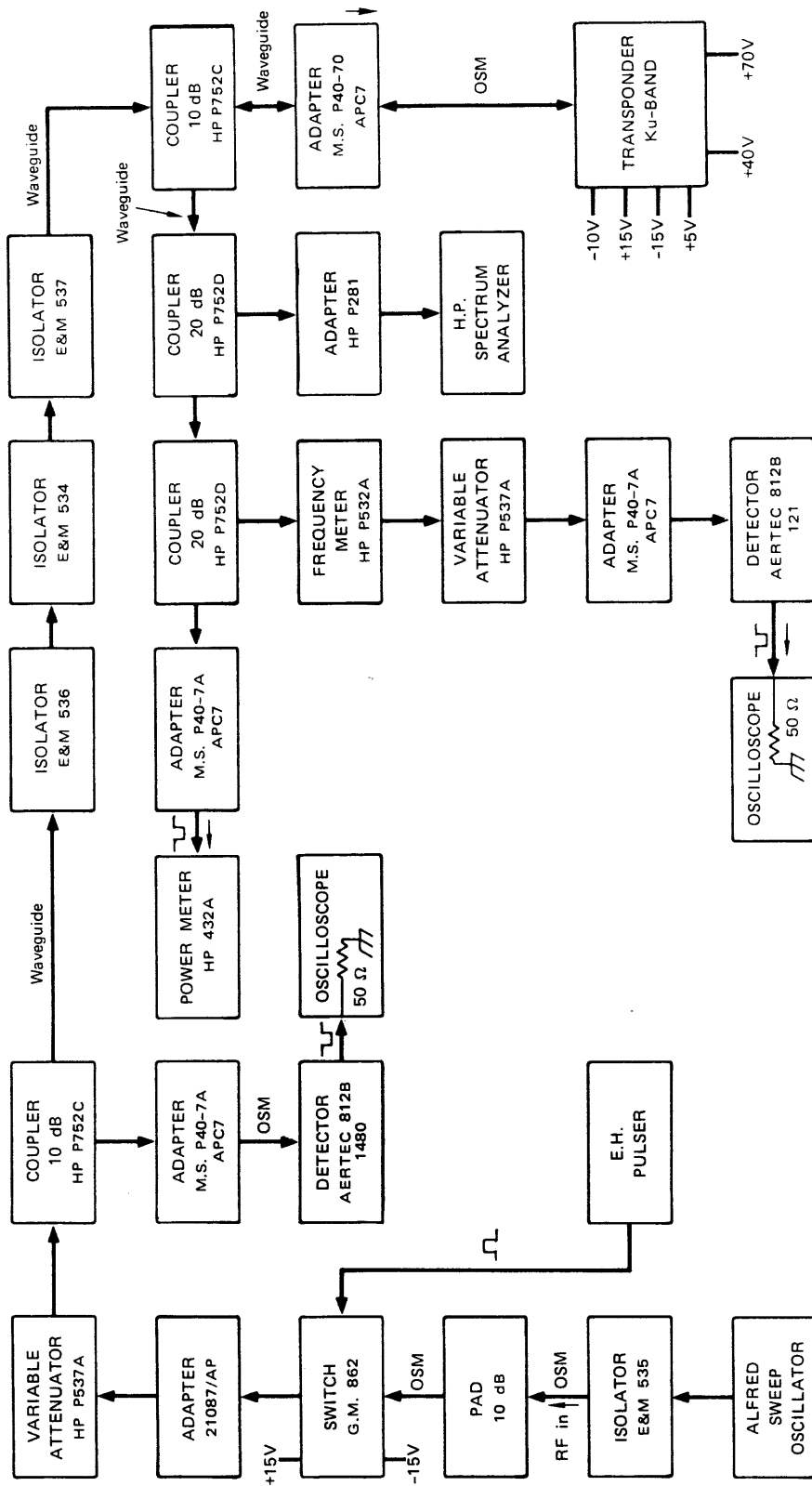
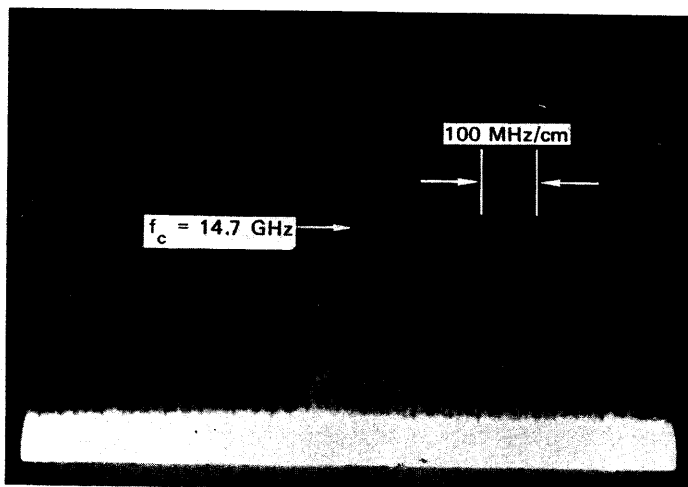

FIGURE V-15 TEST SETUP TO CHARACTERIZE KU-BAND COOPERATIVE BEACON TRANSPONDER



TA-656583-72

FIGURE V-16 SCHEMATIC OF TEST SETUP TO CHARACTERIZE KU-BAND BEACON TRANSPONDER



Vertical Scales: log

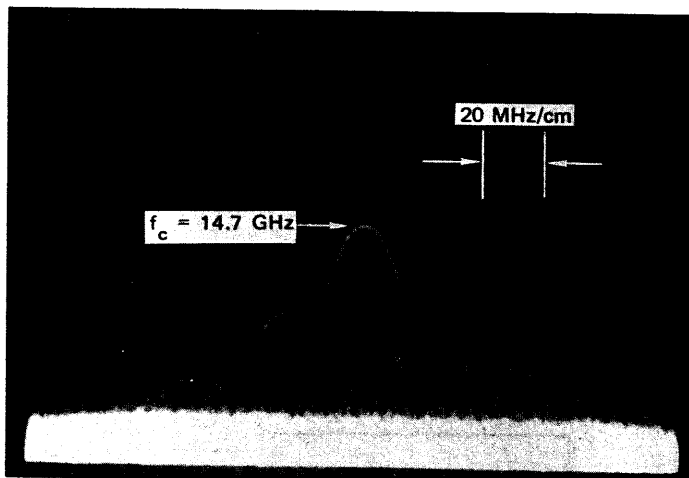

Vertical Scales: log

TA-656583-69

FIGURE V-17 FREQUENCY SPECTRUM OF OUTPUT PULSED RF SIGNAL FROM THE Ku-BAND BEACON TRANSPONDER (sin x/x)

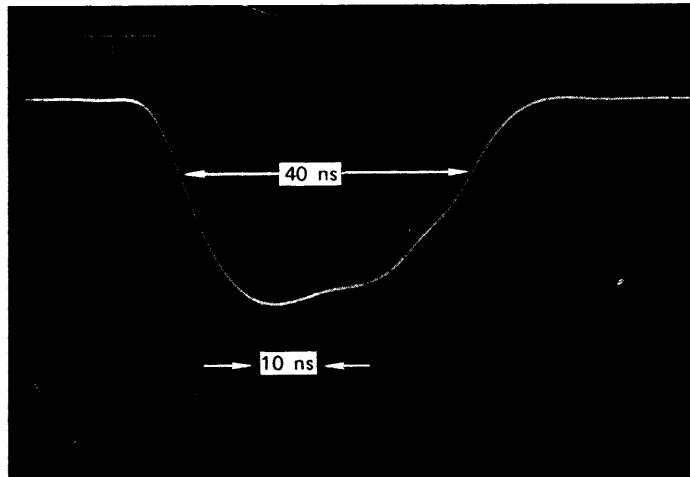

TA656583-67

FIGURE V-18 DETECTED ENVELOPE OF RF INPUT TO THE BEACON TRANSPONDER

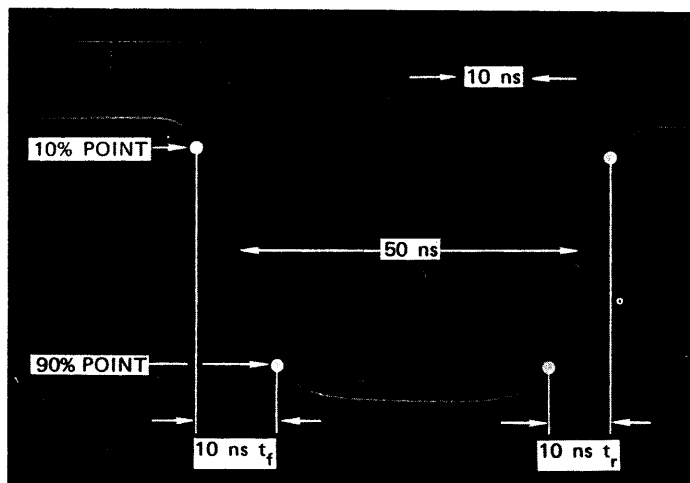

TA-656583-68

FIGURE V-19 DETECTED ENVELOPE OF RF OUTPUT FROM THE BEACON TRANSPONDER

- Figure V-20 shows a fixed delay, through the transponder, of 300 ns between the input and output signals from the beacon transponder. The delay is dependent strictly on the logic gate and delay mechanism built into the processor. With minor adjustments, delay can be reduced to 40 to 60 ns.
- Figure V-21 shows the repetition period of the input and output detected signals from the beacon transponder. The input and output signals are synchronized.
- Figure V-22 shows the current and voltage response of the IMPATT diode oscillator. The pulse voltage waveform is superimposed on top of a fixed dc voltage of +63 volts.
- Figure V-23 shows T²L logic pulse-train waveforms at the input and output of the signal-processing system. Also shown in the above figure is the detected leakage pulse due to the IMPATT diode oscillator. Although the leakage signal is present at the input to the gate, it can be seen that there are no effects to the current modulator signal or to the delayed signal to the RF switch.

Measurements were also performed on the dynamic range of the receiver by varying the input-signal power level to the transponder. Lowest power level measured at the input to the beacon transponder was -42 dBm. At this level, output from the transponder was stable. The upper limit measured was 0 dBm. This corresponded to the maximum available power from the test equipment. The receiver has a self-built limiting feature that could stand very high power levels without damage. Limiting factors are the breakdown limits of the diode detector in the beacon receiver.

1. Operating Voltage and Current Requirements

During the development of the beacon transponder no attempts were made to reduce or simplify the requirement of the dc power-supply system. As a result, different dc voltages were used, as follows:

- 11 volts, current drain 1 mA
- +36 volts, current drain 10 mA
- +63 volts, current drain 1 mA
- +15 volts, current drain 250 mA
- 15 volts, current drain 15 mA
- +5 volts, current drain 150 mA.

Total dc power consumption is approximately 5 to 6 watts.

2. Efficiency of IMPATT Diode Oscillator

The total pulse voltage requirement of the double-drift IMPATT diode was +78.5 volts. The pulse current requirement was 0.9 amps. The peak power output from the IMPATT oscillator measured at a frequency of 14.7 GHz was 4.8 watts. Therefore the efficiency of the IMPATT diode oscillator is approximately 7%. This is lower than the expected efficiency of 10%.

3. Output Power from Beacon Transponder

Owing to losses in the biasing network at the output of the IMPATT diode oscillator and isolators, the maximum available peak power output from the beacon transponder actually achieved was 2.4 watts. This power level is sufficient for a maximum target enhancement range of 4 miles in 16 mm/hr rain with a probability of detection of 0.95 if a T.I. ASD radar with receiver noise of 4.5 dB is used.

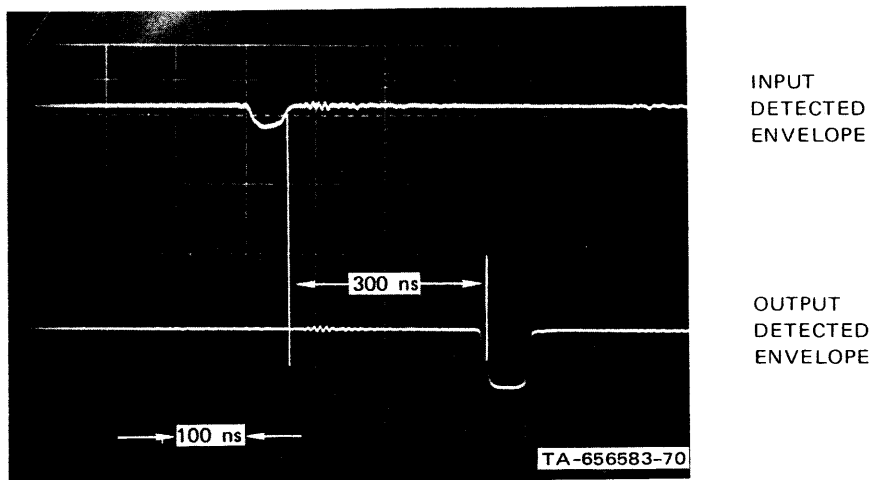

FIGURE V-20 DELAY BETWEEN INPUT AND OUTPUT PULSED RF SIGNALS TO THE BEACON TRANSPONDER

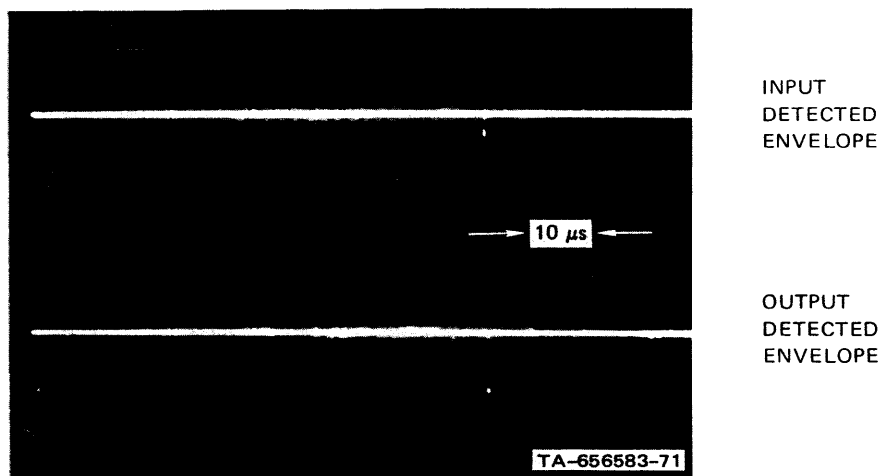

FIGURE V-21 REPETITION RELATIONSHIP OF INPUT AND OUTPUT PULSED RF SIGNALS TO THE BEACON TRANSPONDER

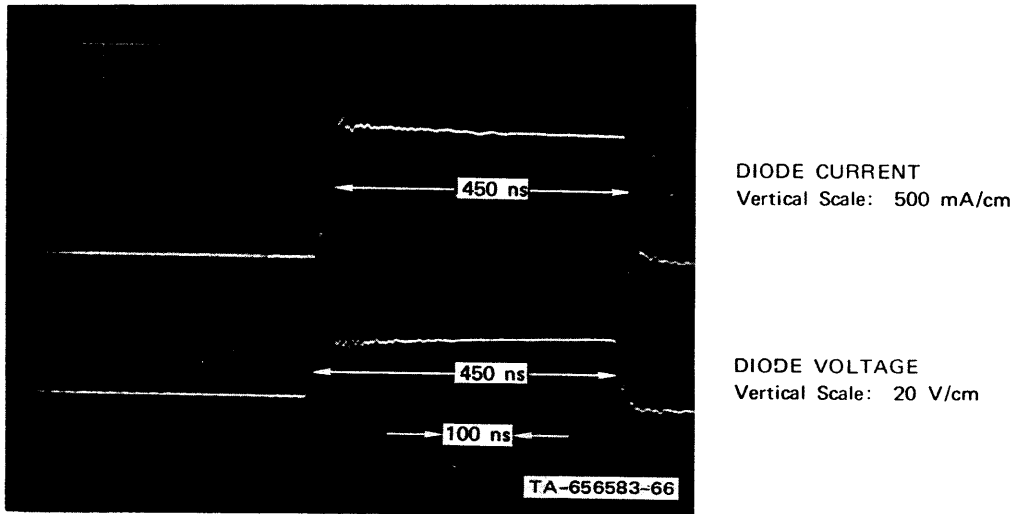
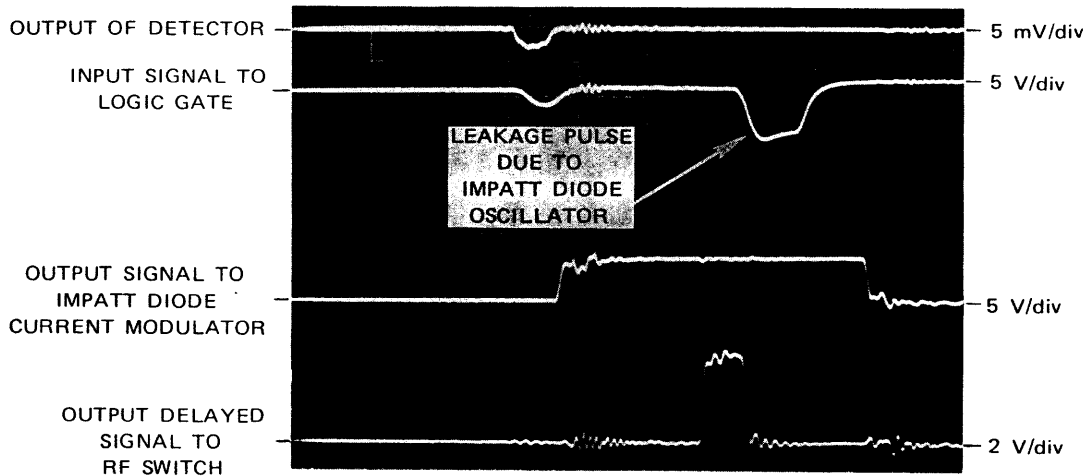

FIGURE V-22 IMPATT DIODE OSCILLATOR CURRENT AND VOLTAGE RESPONSE



SA-1970-45

FIGURE V-23 LOGIC-PULSE-TRAIN WAVEFORMS AT THE INPUT AND OUTPUT OF SIGNAL-PROCESSING SYSTEM

F. CONCLUSIONS

The characteristics of the cooperative beacon transponder are tabulated in Table V-1. In this table the designed and measured results are compared. All the design goals were achieved except the power output. The power output was slightly low (2.4 watts instead of 3.3 watts) because of excessive losses in the output insulator and switch (3.2 dB instead of 2.8 dB) and lower efficiency of the IMPATT diode oscillator (7% instead of 10%). If this transponder is used with a simple dipole antenna (gain 2.2 dB) in the field tests, then the effective radiated peak power available will be measured greater than 3.3 watts. The receiver sensitivity was slightly better than the theoretical because the noise figure of the video amplifier used was lower.

Based on a transmitted peak power of 2.4 watts from the beacon transponder, the maximum range to the ASD radar achievable is 3.5 miles in 16 mm/hr of rainfall and greater than 5 miles in clear weather. By reduction of losses in the RF switch and insulator, more power can be achieved at the output of the transponder. Based on the beacon-transponder receiver sensitivity of -30 dBm, the maximum range from the ASD radar achievable is 1.60 miles in 16 mm/hr of rainfall and 2.5 miles in clear weather.

The dynamic range of the RF power input is from -42 dBm (noise level) to 0 dBm. The lower limit is set by the diode detection noise level. The upper limit is arbitrary and represents the available power from the test equipment.

Table V-1. Characteristics of the Cooperative Beacon Transponder

| Parameters | Designed | Measured | Comments |
|---|---------------|-----------------|--|
| Transmitter | | | |
| frequency | 14.5 | 14.7 GHz | Can be set to any frequency, depending on the design of cavity in the oscillator. |
| Pulsewidth | 50 ns | 50 ns | 35 ns minimum. Maximum value depends on IMPATT diode circuit. |
| Peak power | 3.3 W | 2.4 W | Higher power levels can be obtained depending on IMPATT diode circuit using multiple diodes. |
| PRF | 15 ±0.5 kHz | 15 ±0.5 kHz | 15 ±0.5 kHz. Variable; thus parameter is not critical. |
| Delay | 300 ns | 300 ns | 40 ns minimum. Maximum value variable. |
| Receiver | | | |
| frequency | 14.3 GHz | 12-18 GHz | 12-18 GHz, can be set to any frequency. |
| Minimum detectable power level | -42.5 dBm | -42 dBm | Intermittent output signal from the transponder. |
| Sensitivity with SNR = 13.8 dB, and probability of detection 0.95 | -28 dBm | -30 dBm | -30 dBm. For higher selectivity, use mixer receiver. |
| Video bandwidth | 50 MHz | 50 MHz | 50 MHz maximum (limited by logic circuit bandwidth). Selectable for larger bandwidths by using high-speed circuits. |
| Antenna | | | |
| Gain | None | None | 2.2 dB for simple dipole |
| Power consumption, dc | Not specified | 6 watts maximum | No attempts were made to reduce dc power consumption or design a power supply. IMPATT diode oscillator draws power only during the pulse period. |

VI. STATE OF THE ART IN SOLID-STATE-DEVICE CAPABILITY

A. GENERAL

The performance and cost of a beacon transponder operating at any frequency depend greatly on the active devices used in the designs. The complexity of the beacon receiver or the transmitter can be reduced if high-quality solid-state devices are used. As advances are made in semiconductor technology, lower-noise diodes or FET's will be available for receiver designs and high-power diodes or bipolar transistors will be available for transmitter designs. In the following subsection, the performance of state of the art solid-state devices for receivers and transmitters are reviewed.

B. SOLID-STATE DEVICES – DIRECT-GENERATING

1. General

All solid-state devices used for direct generation have performance limitations; the first and most fundamental is an electronic one resulting from the material properties of finite breakdown fields and carrier velocity limitations. This limit also applies to Gunn, LSA, and transistor devices.

The electronic limit can be expressed as^{1,2}

$$PX = \frac{K}{f^2}$$

where

P = Maximum power deliverable

X = Device reactance

f = Optimum operating frequency

K = Constant applicable to each type of device.

From this equation it can be seen that the power from the device would scale as $1/f^2$ due to the electronic limitation. The second effect is known as the frontier effect. This effect is due to technological advancement. The frequency at which the frontier effect begins to limit the available power generally increases as improvements are made in such factors as doping profiles and electrode geometry.

The third limitation is a thermal one. The low-frequency limitation of the CW device tends to be thermal.

The existence of these three limiting factors makes it difficult to compare very different devices on an equal basis. A practical thermal limit is movable by redefining the device geometry or by improving the heat-dissipation characteristics. Frontier limitations are removed as better design and production techniques are developed.

2. Bulk-Effect Diodes

Bulk-effect diodes made their debut in 1963 when J.B. Gunn of IBM first reported on microwave oscillations of currents in III-V semiconductors. Unlike conventional junction devices that are used for IMPATTs and TRAPATTs, these diodes have an active region of bulk semiconductor (usually GaAs) material that does not require a p-n junction to generate microwave power. When n-doped material is dc-biased, a charge layer is generated at the negative terminal and propagates through the material.

Two basic operating modes are used in bulk-effect diode circuits. They are domain and LSA modes.

In the domain mode, the charge layer is allowed to mature, forming a highly concentrated domain of propagation charge. By control of the formation of this charge, a limited space-charge accumulation LSA mode exists, yielding high pulse powers and efficiencies when compared with domain-mode circuit.^{3,4}

3. IMPATT Diodes

A review of IMPATT diodes was initiated to determine their applicability for providing necessary power for a beacon transponder in D, E, I, J, or K-bands. In this study, a literature search was made and also various manufacturers were contacted.

Figure VI-1 shows the results reported in the literature of some of the best output powers (obtained in a laboratory environment) as a function of frequency for IMPATT diodes.⁵⁻⁹ Results for both CW and pulsed operation are shown. Data on GaAs diodes and double-drift silicon diodes are included. Of particular interest for transponder applications are the results for commercially available pulse IMPATT devices at 10, 16, 24, and 35 GHz. These are values quoted to SRI by Hewlett-Packard in a private communication; the devices are not necessarily available to the public at present.

There is usually a time lag between reports of device capability in the literature and the commercial availability of solid-state devices with similar characteristics. Hewlett-Packard Associates was asked to provide the characteristics of avalanche diodes that are or soon could be available to SRI. The results they quoted are shown in Figure VI-1 and are also summarized in Table VI-1.

Table VI-1. Peak Power From Hewlett-Packard IMPATT Diodes

| F (GHz) | Duty Cycle (percent) | Pulse Width (μ s) | P _{out} (Peak) (watts) | η (percent) |
|------------|-------------------------|---------------------------|------------------------------------|---------------------|
| 10 | 10 | < 8 | 10 | ~ 12 |
| 16 | 10 | < 8 | 5 | |
| 25 | 10 | < 8 | 4 (Est.) | |
| 35 | 10 | < 8 | 3 | ~ 4 |

Curves of $1/f^2$ for both silicon and GaAs IMPATT devices are shown in Figure VI-1. The silicon devices have a larger power impedance product than the GaAs devices although the GaAs devices are usually more efficient.

At higher frequencies (above 60 GHz) the output power tends to drop at a rate faster than the $1/f^2$ curve for silicon IMPATTs would predict. This departure is not necessarily related to any fundamental limitation but is due to a lag in the device and circuit technology at the higher frequencies.

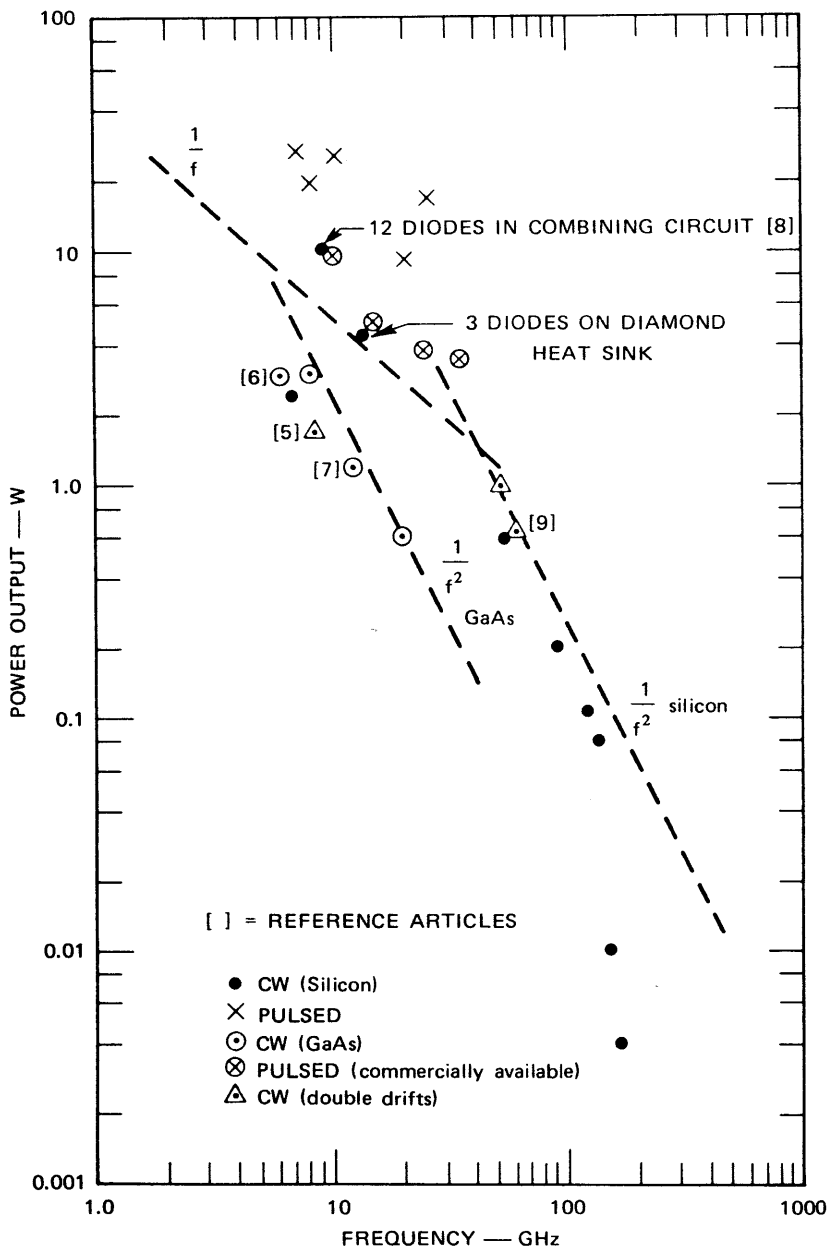

SA-1970-1R

FIGURE VI-1 PERFORMANCE OF IMPATT DIODES — 1973

At lower frequencies a third limit on device operation becomes dominant. This limit is a thermal one and depends on the heat-dissipation properties of the device and associated heat sink. The devices are generally capable of handling higher powers than can be thermally dissipated. This is evidenced by the pulse powers generally following the $1/f^2$ curve, while the CW powers drop below the curve at lower frequencies.

The results of Figure VI-1 show that the following peak pulse powers are consistent with the $1/f^2$ curve for the best results observed in laboratory environments:

| Frequency (GHz) | Peak Pulse Power (Watts) |
|--------------------|-----------------------------|
| 10 | 25 |
| 16 | 9 |
| 25 | 4 |
| 35 | 2 |

4. TRAPATT Diodes

A review of the literature was also made to determine the state of the art of TRAPATT, or high-efficiency-mode, avalanche diodes. These devices are characterized by high peak powers, high efficiency (20% – 60%) and pulse operation. Recent research by various organizations has also been directed to obtaining CW operation. Usually the output power and efficiency decrease appreciably for CW devices, however.

Figure VI-2 summarizes some of the laboratory results reported to date in the literature. These devices also exhibit the same three limitations discussed briefly for IMPATT diodes. From Figure VI-2 it is evident that the TRAPATT devices are essentially limited (at present) to operation below 10 GHz. There have been a few reports of operation at higher frequencies, but the state of the art in these devices is at X-band and below. One reason for this fact is that the TRAPATT operation requires control of the circuit impedances as seen by the avalanche diode at the harmonics of the fundamental frequency. Control of these impedances at the higher frequencies is difficult. Also, the dimensions of the diode depletion region become very small for high-frequency TRAPATT devices, and improved technology is required. The TRAPATT devices may have potential (see Figure VI-2) for higher peak powers above S-band than IMPATT devices, but the state-of-the-art development of IMPATT devices for K-band is considerably advanced over that for TRAPATT devices.

5. Gunn Diodes

After reviewing the various articles and publications on Gunn diodes, an up-to-date performance capability was determined. As a summary for this investigation, maximum power levels with respect to frequency reported on the Gunn diodes have been plotted in Figure IV-3. The mean performance $1/f^2$ relationship for the 1971 state of the art on Gunn diodes has been plotted in the same figure. Also, the $1/f^2$ relationship projected by J.D. Adams¹⁰ for 1975 Gunn diodes has been plotted for comparison with the 1973 diode capabilities and for reference purposes.

It can be seen from Figure VI-3 that Gunn diodes are capable of producing 0.19 watts CW at 40 GHz and 0.12 watts CW at 50 GHz.¹¹ This agrees with a projection made by J.D. Adams.¹⁰ Therefore it is very likely that in the next two years, diodes will be available that will generate 3 watts CW at 10 GHz.

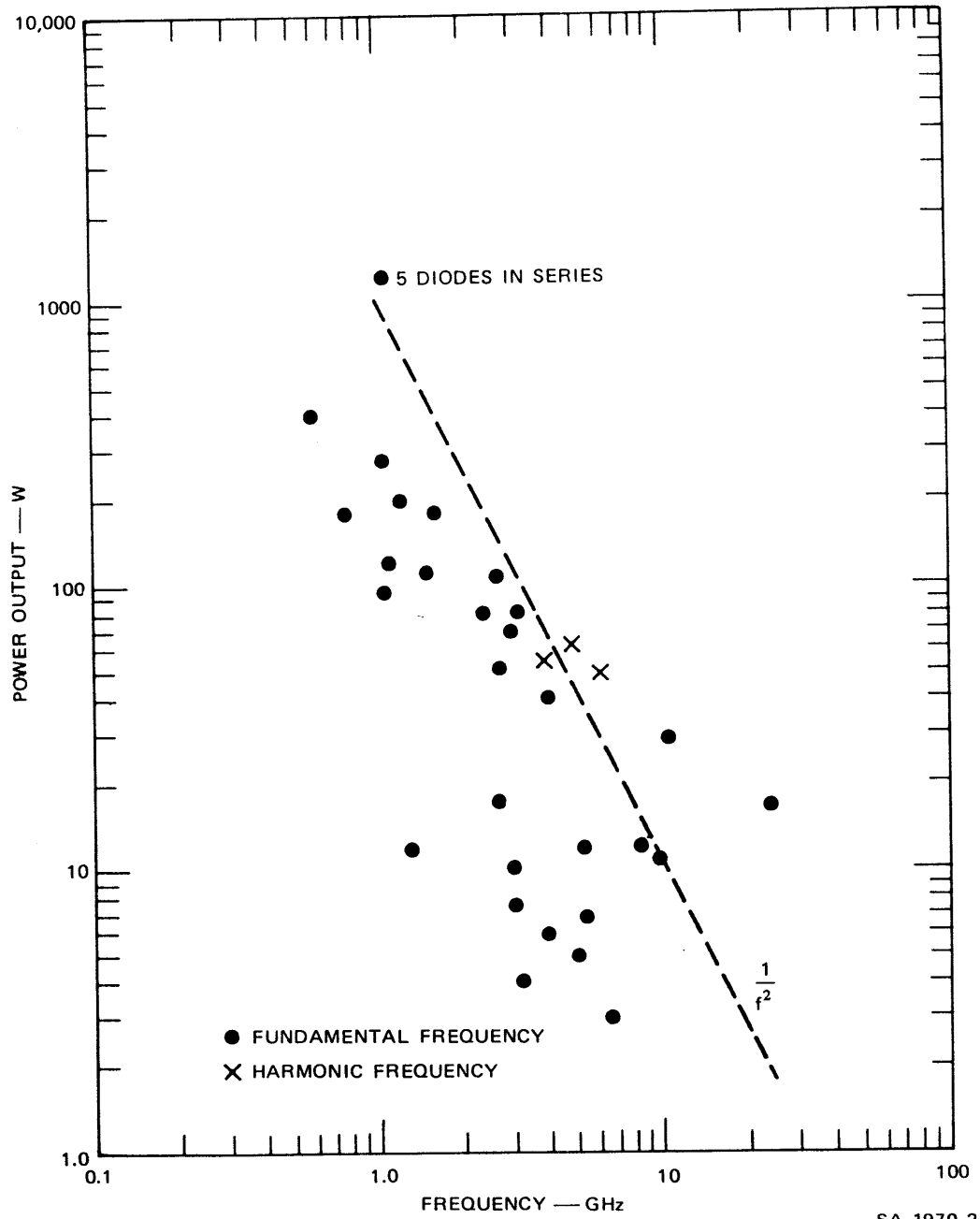

FIGURE VI-2 PERFORMANCE OF TRAPATT DIODES — 1973

At the frequencies of interest for the application of ASD radars, it has been demonstrated in the laboratories that Gunn diodes can presently produce the following powers (Figure VI-3):

| <u>Frequency (GHz)</u> | <u>CW (W)</u> | <u>Pulse (W)</u> |
|------------------------|---------------|------------------|
| 16.5 | 0.4 | 4 |
| 24 | 0.175 | 2 |
| 35 | 0.1 | 1 |

Literature and advertisements by various companies making Gunn diodes were also reviewed. Some of the diodes available commercially are listed in Table VI-2.

Table VI-2. Performance of Commercial Gunn Diodes

| Manufacturer | Model | Power Output | Efficiency (percent) | Frequency (GHz) |
|--------------|-----------|--------------|----------------------|-----------------|
| Alpha | DGB-6204A | 200 mW CW | 2 | 16.5 |
| MA | MA-49114 | 250 mW CW | — | 16.5 |
| MA | MA-49168 | 100 mW CW | — | 24 |
| MA | MA-49173 | 50 mW CW | — | 30 |
| MA | MA-49265 | 4 W Pulse | — | 16.5 |
| Litton | LS-1431 | 250 mW CW | 3 | 16.5 |

A few Gunn diode manufacturers were contacted regarding the performances of such diodes. The information obtained from them is as follows:

- Varian Associates, Palo Alto, California, makes Gunn diodes but their power output levels are of the order of 20 mW at X-band.
- Litton Industries Ltd., San Carlos, California, has developed a circuit that uses four Gunn diodes that can produce 750 mW to 1000 mW CW at 16.5 GHz. Cost of such diodes is \$250 each when ordered in small quantities. When ordered in quantities of more than 100, the cost is \$125 each.
- Not many commercial Gunn diode manufacturers have experience in pulsed Gunn diodes. Both Litton of San Carlos and Alpha Industries, Woburn, Mass., indicated that it is possible to obtain pulse peak power five to seven times the CW power of each diode they sell commercially.

Gunn diode oscillator and amplifier circuits were also reviewed. It appears that most of the circuit developments on the Gunn diode oscillators have been in the microwave cavity designs. This is primarily because of the broad bandwidth capability of the diodes that require high-Q filter circuits to maintain oscillation at a given frequency. Microwave cavity designs are unsuitable for transponder beacon application where stripline or microstrip techniques are used in order to keep the manufacturing cost to a minimum.

All popular and commercial Gunn diodes are made of GaAs bulk semiconductor material, but in 1970, Hilsum and Rees¹⁶ suggested that materials in which electron energy transfer occurred between three sets of minima have certain advantages over GaAs transferred electron devices. Advantages are higher peak-to-valley ratio, lack of domain, and suppression of avalanching in domains. The simple material suggested was InP. However, this theory has not yet been proven.

Engineers at Royal Radar Establishment, Malvern, Worcester, England, and Plessey Co., Surrey, England,¹⁷ have been working on this type of Gunn device. Their experiments with pulsed oscillators have been from 1 GHz through 40 GHz. The following table shows some results of their experiments:

| <u>Peak Power</u> | <u>Frequency (GHz)</u> | <u>Efficiency (percent)</u> |
|-------------------|------------------------|-----------------------------|
| 10 W | 1.7 | 4 |
| 1 W | 8.5 | 7 |
| 650 mW | 25.0 | 2.6 |
| 100 mW | 33.0 | 0.4 |

6. LSA Devices^{4, 18}

The LSA diode has lower capacitance and greater power output capability than either IMPATT or Gunn devices. In this device, high-field traveling-domain characteristics of bulk-effect devices are not permitted to form. The oscillating field across the device rises above and falls back to the threshold level too quickly for domains to take shape. A small charge that does not manage to accumulate, dissipates rapidly when the field drops below threshold. Charge density is therefore uniform within the bulk sample. The entire device acts as a negative resistance independent of the length of the sample and without any transit-time effects. LSA devices can also operate at much higher peak power levels than can Gunn. This mode needs a dc bias several times the threshold, but the RF field must still be able to drop below the threshold.

At low duty cycles, no self-heating occurs, but at high duty cycle, self-heating does occur and efficiency drops. For LSA diodes¹⁸ the theoretical peak output power is given by

$$P_K = 2 \times 10^{16} \left(\frac{E}{R_0} \right) \left(\frac{L}{L_{TT}} \right)^2 \left(\frac{1}{f^2} \right) \quad (\text{VI-1})$$

where R_0 is the low-field positive resistance, L is the transit-time thickness, and E is the electric-field intensity of the device.

It is interesting to note that in the LSA devices, the peak power is proportional to $1/f^2$ and average power is proportional to $1/f^4$. In Figure VI-4, the maximum-peak-power plot for LSA diodes is plotted using the peak-power equation for $L/L_{TT} = 1000$, $R_O = 15$ ohms, and $E = 10^4$ V/cm. Included are plots for $L/L_{TT} = 100$, 25, and 10. Also, experimental pulsed-peak-power data on LSA diodes achieved by various researchers in the field have been plotted in the same figure. A mean line is drawn through the experimental points for comparison with results predicted by others. It appears that the 1973 capability in LSA diodes exists between $L/L_{TT} = 25$ and $L/L_{TT} = 100$. The mean line drawn by J.D. Adams¹⁰ in 1971 is lower than the 1973 projected peak power capability. In the original paper by L.F. Eastman¹⁸, plots were made for L/L_{TT} versus duty cycle for 200°C junction temperature rise. Pulsewidths of 5 μ s were considered in these calculations. A plot for the average power has also been considered in the same paper. The highest average power calculated at 10 GHz was 5.5 W for $L/L_{TT} = 100$. If the value of R_O is lowered to 1.5 ohms, the calculated average power can be raised to 18 W.

L.F. Eastman¹⁹, in his paper on the utilization of LSA diodes for a pulse RF transmitter, explained the difficulties and expertise required in the understanding of the LSA diode oscillator circuits. Presently, LSA diodes are not applicable for practical transmitter designs because of the bulky-power-supply requirements and lack of reliability of such diodes due to burn-out problems. Cayuga Associates, New York, was once the only supplier of LSA diodes, though RCA Corporation, Camden, New Jersey, has the capability and supplies diodes to its own research laboratories. Due to diode burn-out problems and lack of understanding by the users, Cayuga does not sell the diodes without the power supplies and pulse modulators. Therefore, we should rule out the possibility of using LSA diodes in our transponder techniques, unless some breakthroughs occur in the near future.

C. SOLID-STATE DEVICES – RECEIVER DIODES

1. General

Three types of receiver diodes are compared in Table VI-3.

Recent developments in diode materials have allowed fabrication of junctions less than 0.0001 inch in diameter to advance the practical operating limit for Schottky diodes well into K-band. Diodes are available with noise figures of below 5 dB at X-band, while laboratories are reporting useful performance at frequencies past 50 GHz. Tangential sensitivities of -55 dBm are guaranteed for frequencies past 10 GHz with 1 MHz bandwidth. Within the next two or three years, silicon diodes with 7.5 dB noise figure and less than -50 dBm tangential sensitivity at 30 GHz will be commercially available.

The processing technology for Schottky diodes is concentrating on reducing junction diameter, increasing burnout capability, and lowering noise. For the frequency of operation to increase, the area of the junction must be reduced by at least the square root of the frequency ratio. This requires fine oxidation and photoresist and masking techniques. Oxides used are silicon dioxides and silicon nitride. The thickness of oxides must be controlled within 100 Å. Beam-lead Schottky devices are growing in popularity because they are ideally suited for MIC work. The chief limitation is the excess capacitance caused by the beam.

Schottky-barrier diodes are distinguished from the conventional devices in that the junction consists of metal and a semiconductor rather than two different semiconductors. When an n-type Schottky diode is forward-biased, the majority carriers are injected into the metal at a much higher energy level than the metal's existing free electrons. The electron flow from the semiconductor to the metal occurs with virtually no flow of minority carriers in the reverse direction to cause charge storage. Therefore the response to a change in bias in a Schottky diode is much faster than that in a p-n junction. The lack of stored charge

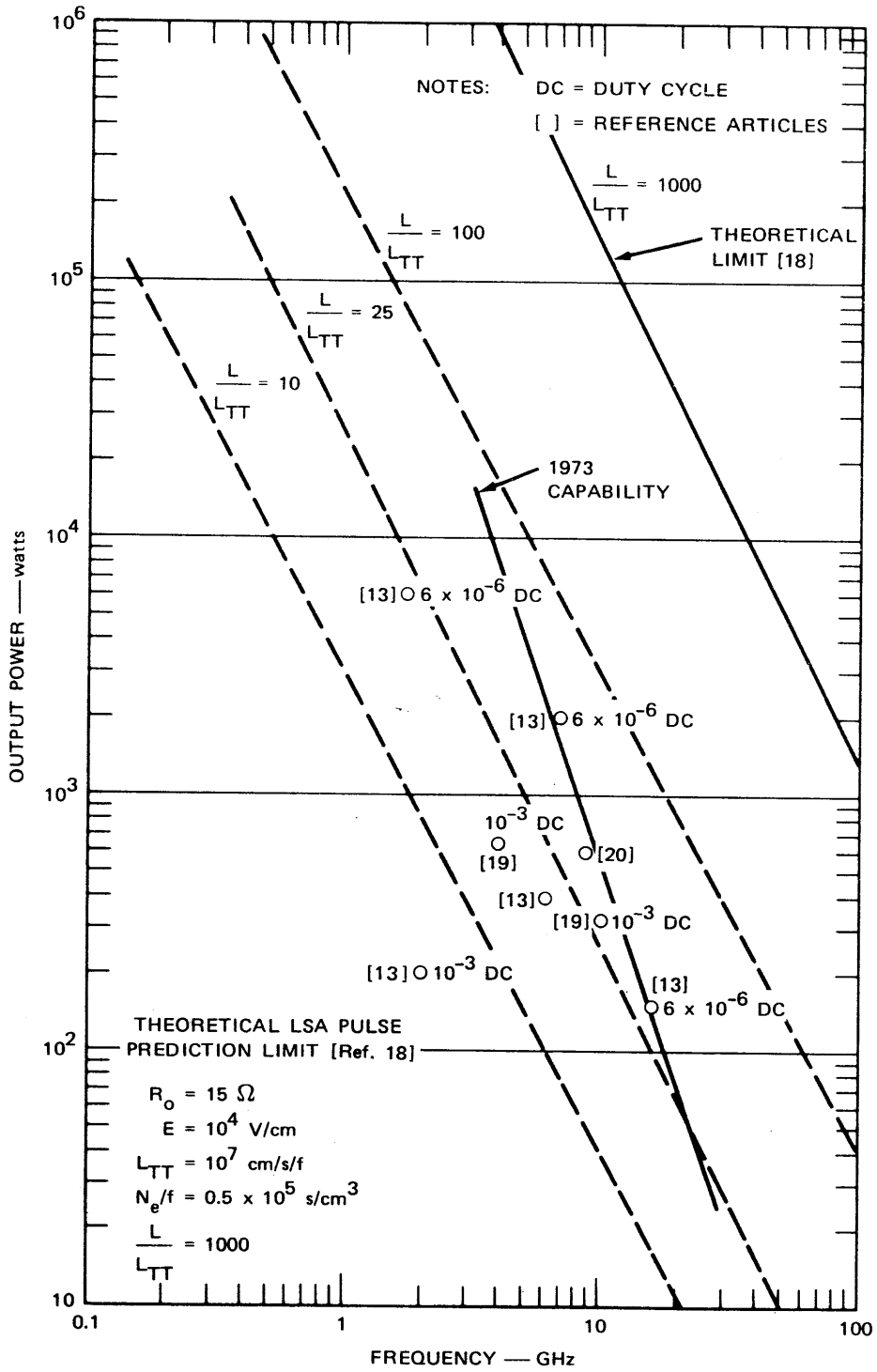

FIGURE VI-4 PERFORMANCE OF LSA DIODES — 1973

Table VI-3. Comparison of Receiver Diode Characteristics

| p-n Junction | Point Contact | Schottky Junction |
|---|---|--|
| <p>Minority-charge flow limits the switching speed</p> <p>Charge storage, low 1/f noise, highest burn-out capability, and operation below 1 GHz</p> | <p>Some minority-charge flow, combination of Schottky and alloyed rectifying junction, high 1/f noise, operation to greater than 100 GHz, and low burnout capability</p> <p>Higher rectification efficiency at low LO levels</p> <p>Excellent as zero bias detector</p> | <p>Majority-charge flow</p> <p>Planar junction with uniform current distribution</p> <p>Low 1/f noise, and operation to greater than 50 GHz</p> <p>Medium burnout capability</p> <p>Lower white noise</p> <p>Bonded Schottky is mechanically more stable</p> <p>Schottky beam-lead diodes for micro-strip</p> <p>Schottky chips for MICs</p> <p>Better dynamic range</p> |

in the junction also reduces drive requirements when the diode is operated as a switch. The fast response and low noise generation make the Schottky diode particularly useful in two important applications – microwave mixers and detectors.

2. Mixer Diodes

The sensitivity of any simple receiver depends on the conversion loss of the mixer and overall noise figure of the mixer-plus-IF amplifier combination. Both the conversion loss and the noise figure of the mixer depend on the RF circuit losses, the selection of the IF, and the type of diodes used. The RF circuit losses can be reduced by matching the diodes to the hybrids and by minimizing the discontinuity losses. Typical circuit loss of 1 dB at X-band can be expected in a balanced mixer.

By selecting a low IF frequency in the range of 30 to 150 MHz, amplifiers are available with noise figures of 1.5 dB or less. As advances are made in bipolar transistors and field-effect transistors, IF amplifiers will be available with very low noise figures (≤ 1.5 dB at 1 GHz) at much higher frequencies. Higher IF's would simplify the RF and IF filter designs used in the receiver for the purpose of reducing spurious and image signals.

The two types of diodes commonly used in the mixer design are Schottky-barrier diodes and point-contact diodes. In the following paragraphs, noise-figure performance of both diodes is discussed.

It can be shown theoretically that the conversion loss of an ideal mixer is 3 dB for all frequencies. This assumes no image-enhancement technique or control of idler currents in the mixer design. Therefore the theoretical noise figure would be 4.5 dB if the mixer is followed by an amplifier with a noise figure of 1.5 dB. In Figure VI-5 the theoretical noise figure of an ideal broadband diode has been plotted. Also plotted are the noise-figure results, with respect to frequency, of Schottky-barrier mixer diodes commercially available in December 1972. For reference purposes, noise-figure results obtained by B.S. Siegal in 1971 are plotted.²¹ It should be noted that the noise-figure data plotted in Figure VI-5 were obtained for mixer diodes that were mounted in waveguide or cavities that have low circuit losses. Practical stripline or microstrip mixer designs have higher noise figures than the data published on single diodes, because of the higher circuit losses.

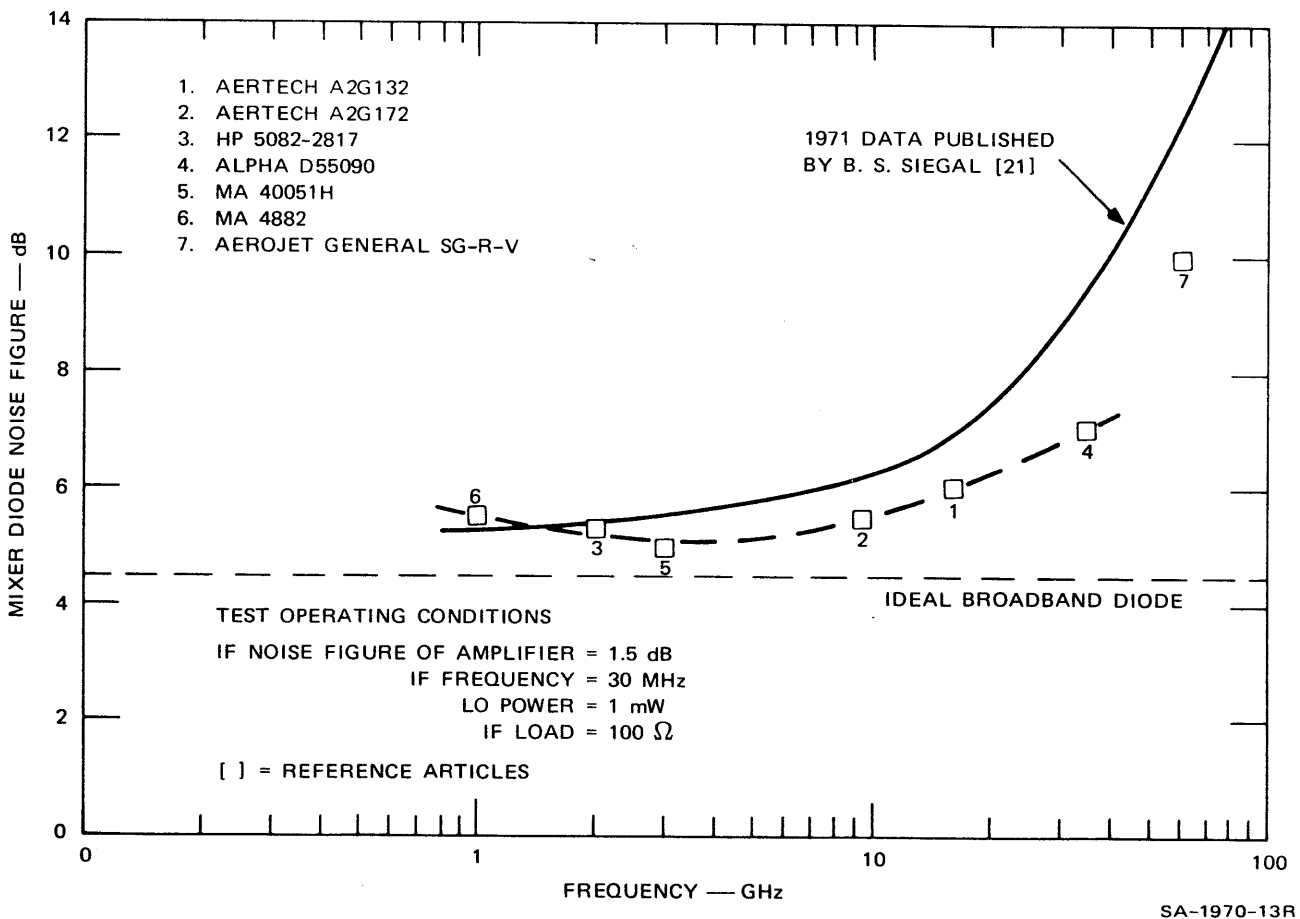

FIGURE VI-5 NOISE-FIGURE PERFORMANCE OF COMMERCIAL SCHOTTKY BARRIER MIXER DIODES — 1973

As seen from Figure VI-5, commercial manufacturers have made diodes in the frequency range of 1 to 10 GHz that are approaching the theoretical noise-figure limit. In fact, diodes are presently available with noise figures of 5.5 dB at 1 GHz and 10 GHz. Theoretically, the noise figure at low frequencies should be lower than the noise figure at high frequencies. The experimental noise-figure numbers are the same because different test circuits were used. Also, manufacturers have concentrated their efforts on obtaining diodes with low noise figures at high frequencies, since bipolar transistors and field-effect transistors are not commercially available at these frequencies nor are they cost-effective. At low frequencies, bipolar transistor amplifiers are available with much lower noise figures (≤ 2.5 dB at 1 GHz) than are available from mixers.

As the GaAs process technology advances, diodes will be available in the next two years with lower noise figure (typically 5.5 dB at 20 GHz) than those plotted in Figure VI-5. However, noise-figure data on diodes will not be less than the ideal broadband diode noise figure of 4.5 dB. Some researchers have published mixer data at C-band with noise figure of 2.2 dB, using image-enhancement techniques to achieve these results.²² Image-enhancement techniques are suitable for narrow-band application though these mixer designs are not simple or cost-effective.

For purposes of comparison, the noise-figure performance of commercially available point-contact mixer diodes has been plotted in Figure VI-6. It appears from this plot that point-contact diodes have a lower noise figure than Schottky diodes. This is due primarily to the advanced state of development in point-contact technology. Point-contact diode construction is not directly applicable for stripline or microstrip fabrication techniques. However, Schottky-barrier diodes are available in beam-lead form for thermal-compression bonding.

3. Detector Diodes

In Figure VI-7, tangential signal sensitivity of silicon Schottky-barrier detector diodes commercially available in 1973 is plotted with reference to frequency. Also plotted for reference purposes is a 1971 performance curve on Schottky-barrier diodes by B.S. Siegal.²¹ It is shown that diodes are now available at X- and K-bands with improved TSS values.

D. SOLID-STATE DEVICES- TRANSISTORS

1. General

There are two basic types of transistors used for low-noise and high-power applications. They are bipolar transistors and field-effect transistors. The state-of-the-art performance of each type was investigated and studied. Results are reported in the following subsections.

2. Bipolar Transistors

a. Low-Noise Transistors

The performance of small-signal silicon bipolar microwave transistors has been significantly improved by three key developments in device technology. These developments are:

- One-micron emitter stripe
- Arsenic diffused emitters
- Ohmic contacts compatible with shallow structures

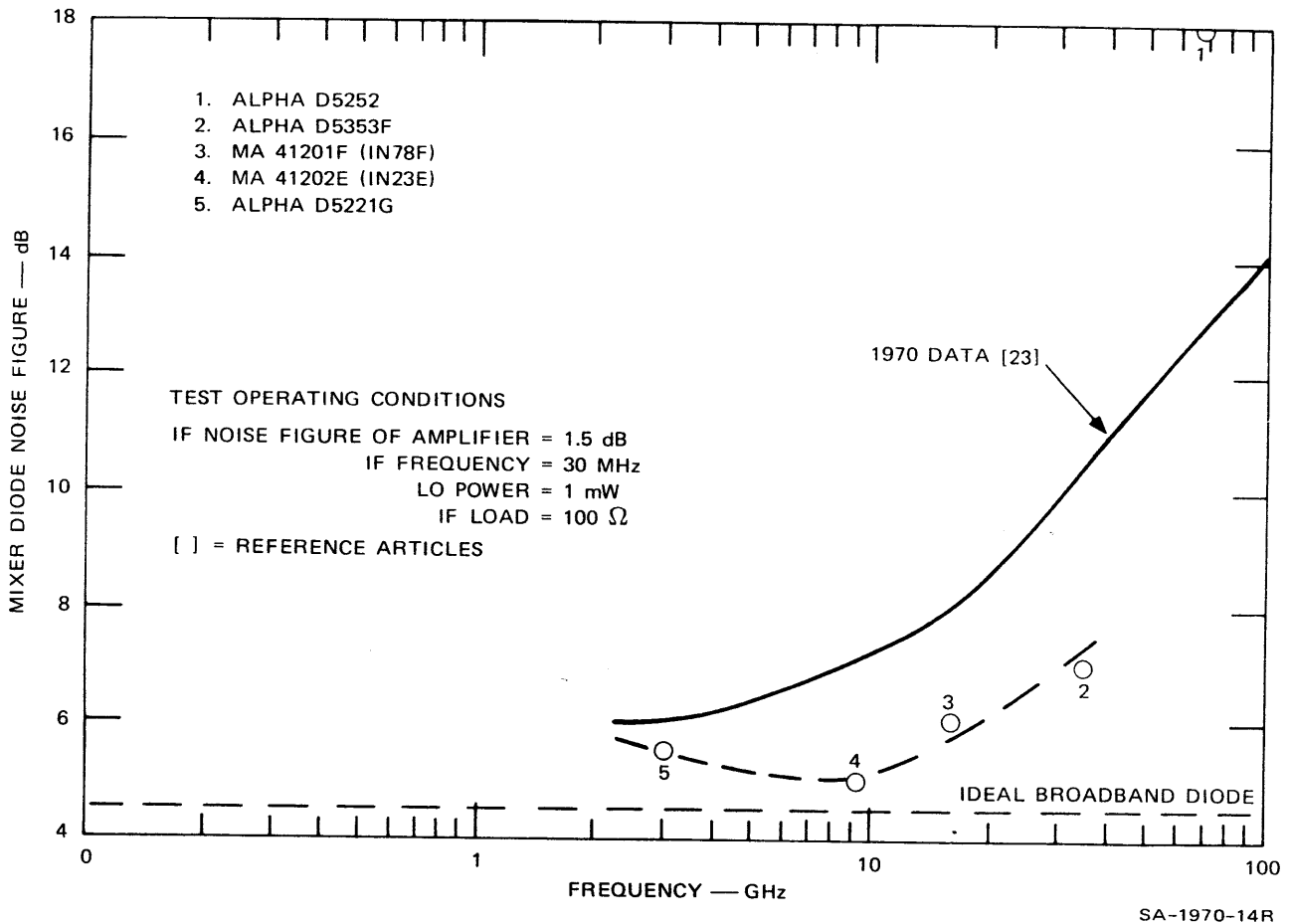

FIGURE VI-6 NOISE-FIGURE PERFORMANCE OF COMMERCIAL POINT CONTACT MIXER DIODES — 1973

The application of these developments has resulted in silicon devices with noise figures as low as 3.0 dB at 4 GHz. Figure VI-8 shows the noise-figure performance of low-noise silicon bipolar transistors commercially available today. Also plotted for reference purposes are the state of the art in bipolar transistors in 1970 and 1971 and a theoretical curve of performance expected in the future. The best noise-figure results obtained to date are 2 dB at 2 GHz (Fairchild MT4000), 2.8 dB at 4 GHz (HP 122), and 4.2 dB at 6 GHz (TI L216C).

The major effect of the reduced emitter width is a reduction of the transistor base resistance. Arsenic diffused emitters provide reduced base transit time and neutral emitter capacitance.²⁴ The alpha cut-off frequency, f_{α} (which together with base resistance determines the high-frequency noise figure), and the current gain bandwidth, f_T , are thereby improved. f_T is determined not only by the emitter base junction capacitance and the base transit time, but also in part by the collector transit time. By using very thin heavily doped collectors, f_T 's as high as 15 GHz have been obtained.²⁵

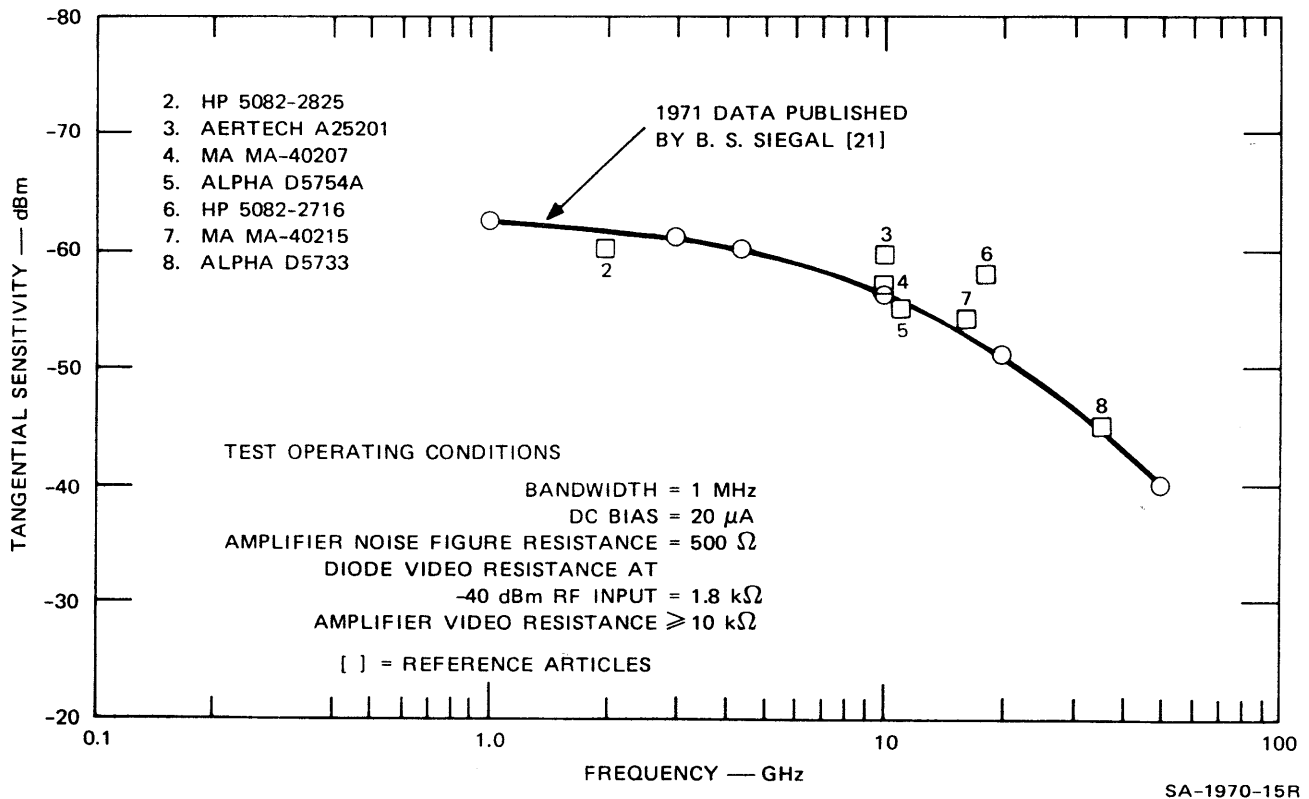
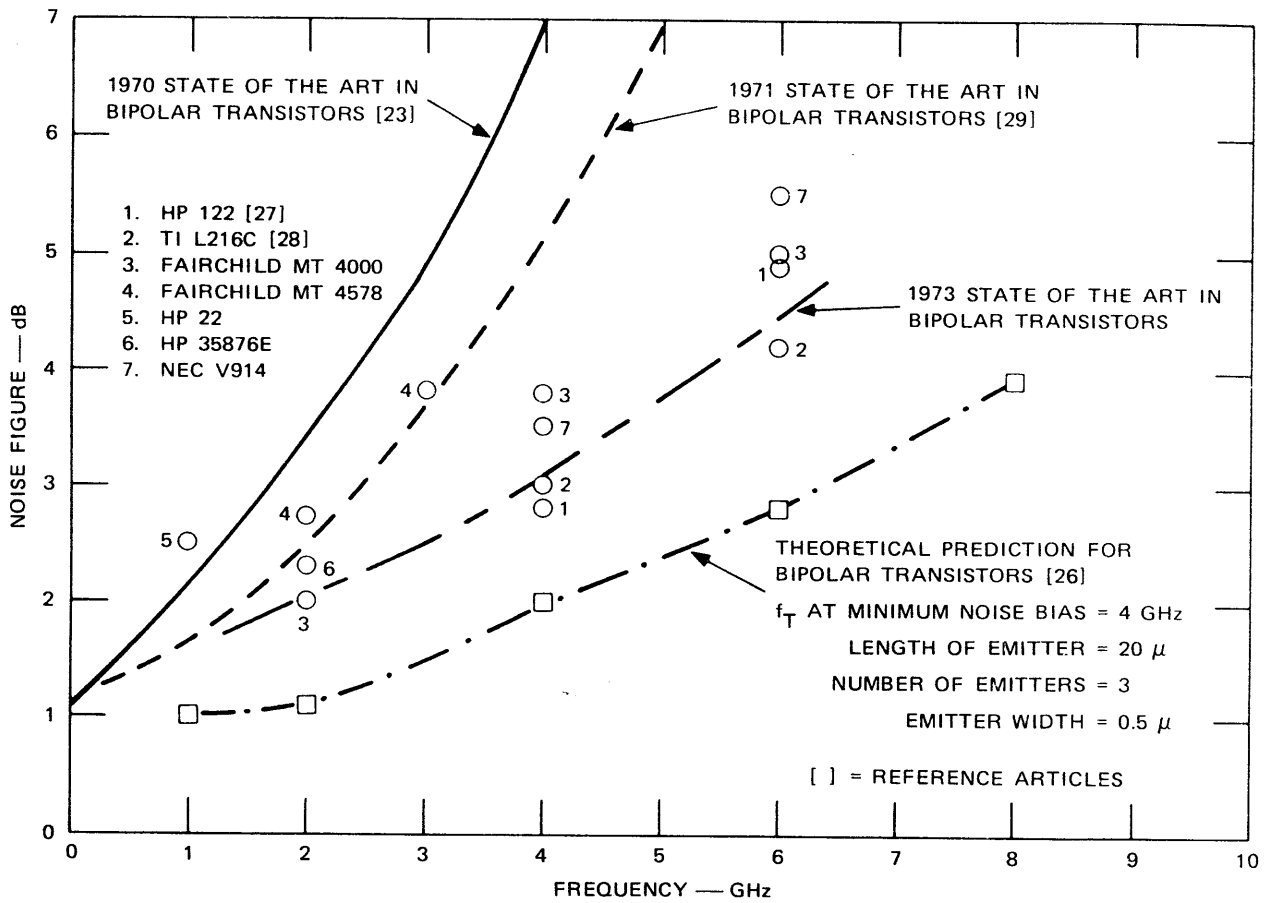

FIGURE VI-7 TANGENTIAL SENSITIVITY PERFORMANCE OF COMMERCIAL SILICON SCHOTTKY BARRIER DETECTOR DIODES — 1973

b. High-Power Transistors

The maximum power of a transistor is limited by the base stretching (Kirk effect), which sets limits on the current, and by the base collector junction voltage breakdown. Recently S. Kakihana of Hewlett Packard Co., Palo Alto, CA, published a paper²⁶ indicating practical limits of power transistors with realistic f_T 's. His results for 5-ohm-output-impedance transistors are plotted in Figure VI-9, as well as some data points of maximum power output from transistors achieved to date by various manufacturers. For comparison purposes, the 1970 state-of-the-art Pf^2 plot²³ and the 1975 output power projects by J.D. Adams³⁰ are plotted in Figure VI-9. If Kakihana's projection and calculations are accurate, bipolar transistors will be available in the future with power levels of 4 watts CW at 12 GHz and 10 watts CW at 4 GHz. Power Hybrids Inc., Torrance, CA, has already developed a transistor that delivers 8 watts at 4 GHz. These power-level numbers are much higher than any available present data on IMPATT or Gunn diodes. It should also be noted that presently transistor amplifiers and oscillators have much higher efficiencies than either IMPATT or Gunn diodes. It appears that in the future, direct-generating devices will serve their usefulness at higher frequencies. At low frequencies (\leq 10 GHz), bipolar transistors will be utilized for high-power application.



SA-1970-16R

FIGURE VI-8 NOISE-FIGURE PERFORMANCE OF COMMERCIAL BIPOLAR TRANSISTORS — 1973

Typical efficiencies and power outputs achieved to date on commercially available bipolar transistors are given in Table VI-4.

Table VI-4. Efficiency, Power Output, and Gain Capability of Commercially Available Bipolar Transistors

| Type and Manufacturer | Frequency, f_o (GHz) | Power Output, P_o (watts) | Gain, G(dB) | Efficiency (percent) | Pulsewidth t (μ s) (10% duty cycle) |
|-----------------------|------------------------|-----------------------------|-------------|----------------------|--|
| MSC 1330 | 1.3 | 30 | 8.5 | 50 | CW |
| MSC 1330 | 1.3 | 70 | 10.0 | 50 | 10 |
| MSC 4005 | 4.0 | 5 | 4.0 | 30 | CW |
| MSC 4001 | 4.5 | 1 | 5.0 | 23 | CW |
| Ref 31 | 3.5 | 5 | 6.0 | 25 | Not Available |

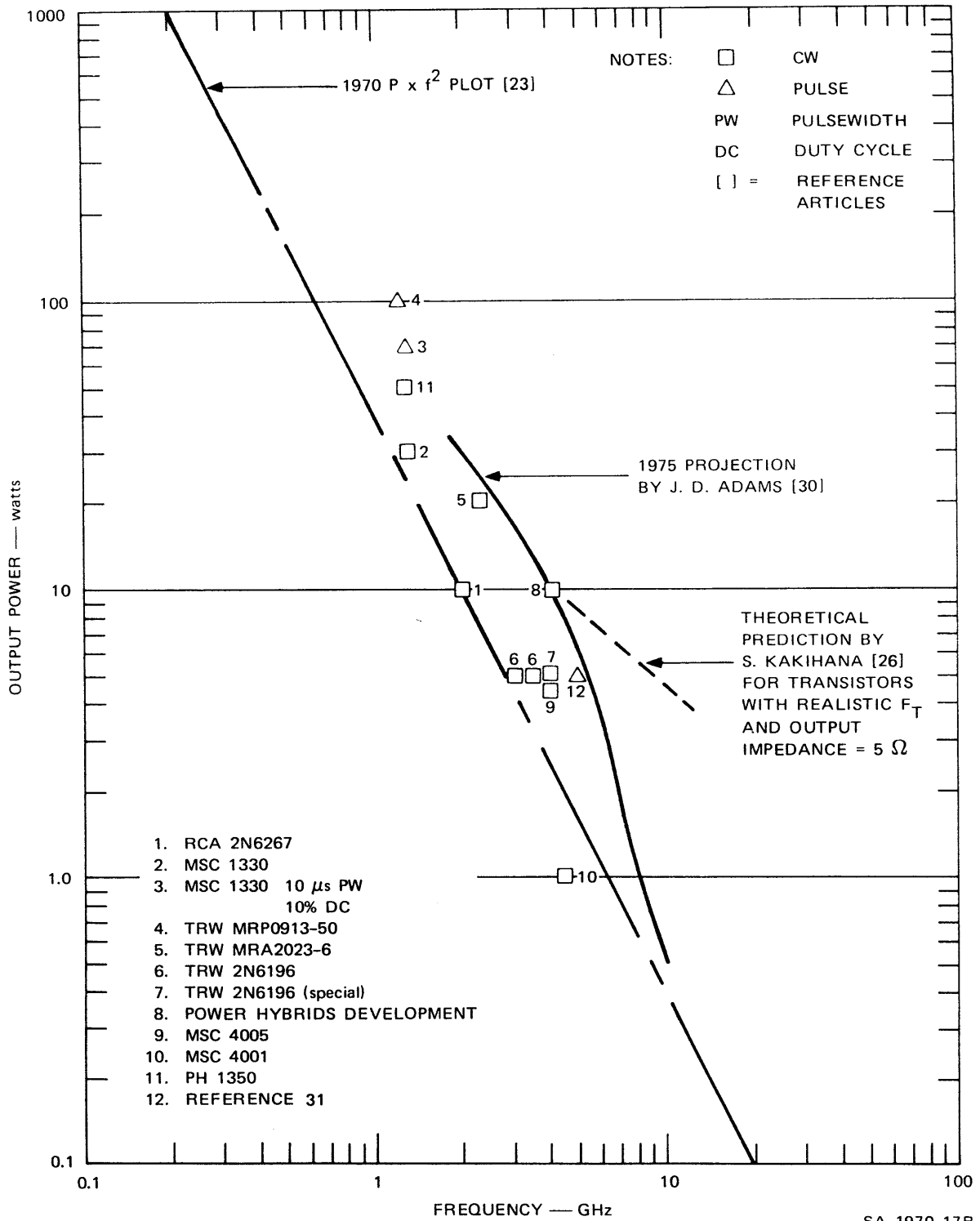

FIGURE VI-9 POWER AS A FUNCTION OF FREQUENCY OF COMMERCIAL MICROWAVE TRANSISTORS — 1973

After review of the published literature, it appears that Microwave Semiconductor Corp. is the leader in the manufacture of high-power, high-efficiency transistors, as exemplified by their type MSC 4005.

In order to achieve even higher power levels, lower-power-level transistor amplifiers can be combined in parallel by using hybrids. Westinghouse Aerospace and Electronic Systems Div., Baltimore, MD,³² recently announced an amplifier that generated 1 kW peak output power at 1250 MHz with an overall efficiency of 35%, 1% duty cycle, and pulsewidths of 5 μ s. Similar techniques can be applied efficiently up to K-band if the solid-state devices are available.

3. Field-Effect Transistors

The FET is surpassing the performance of bipolar types at X-band and beyond; usable gain at frequencies up to 20 GHz have been reported. In addition, simplicity of fabrication offers potential low-cost benefits.

The rapid upsurge in performance of the FET is the result of two important technological advances: (1) the use of a Schottky-barrier control gate, and (2) the use of a high-resistivity substrate material. A high-resistivity substrate material considerably reduces the parasitic losses in the device, giving improved performance. At present, FETs are fabricated in both silicon and gallium arsenide. The high electron mobility and high limiting carrier velocity of gallium arsenide together with their occurrence in the semi-insulating form make gallium arsenide preferable for higher-frequency applications. GaAs FETs are now in development covering C- through Ku-band with very impressive noise figures and unilateral gain compared to their bipolar transistor counterpart. Typical noise figures obtained for laboratory devices are 2 to 3 dB at 4 GHz, 4 dB at 8 GHz, and 5 dB at 12.5 GHz.

Performance of state-of-the-art low-noise FET devices is plotted in Figure VI-10. For comparison purposes, theoretical numbers on noise figure calculated by S. Kakahana are plotted in the same figure.²⁶ Great progress has been made in low-noise FET technology in the last year. Noise-figure results on state-of-the-art FET devices available in 1971 are also plotted as reference in Figure VI-10. Comparing the noise-figure data for FET devices with those of bipolar transistors in Figure VI-8 shows that FET technology has surpassed bipolar technology.

The extrapolated maximum frequency of oscillation, f_{MAX} , for a bipolar transistor was recently reported to be about 25 GHz.³³ FETs, on the other hand, have achieved an extrapolated maximum frequency of oscillation of 40 GHz; higher frequencies can be expected as the technology improves. FETs also offer power gain advantage. Another feature about the FET compared to the bipolar devices concerns the optimum bias conditions. The maximum gain of bipolar transistors is specified at a certain collector current, whereas optimum noise performance is obtained at a much lower collector current. This is not the case with FETs, where both optimum noise and gain performance can be achieved under similar bias conditions. However, the FET is not without some of its own unique peculiarities. The biggest problem is matching over wide bandwidths; impedances are both high and reactive. As a result of this, existing transistor packages are not suitable for FET devices.

To date, FET technology has concentrated on low-noise-amplifying devices. Eventually, high-power FET devices will be available for low-noise local-oscillator applications. These devices may also compete in performance with IMPATT and Gunn diodes in the near future (perhaps two to three years).

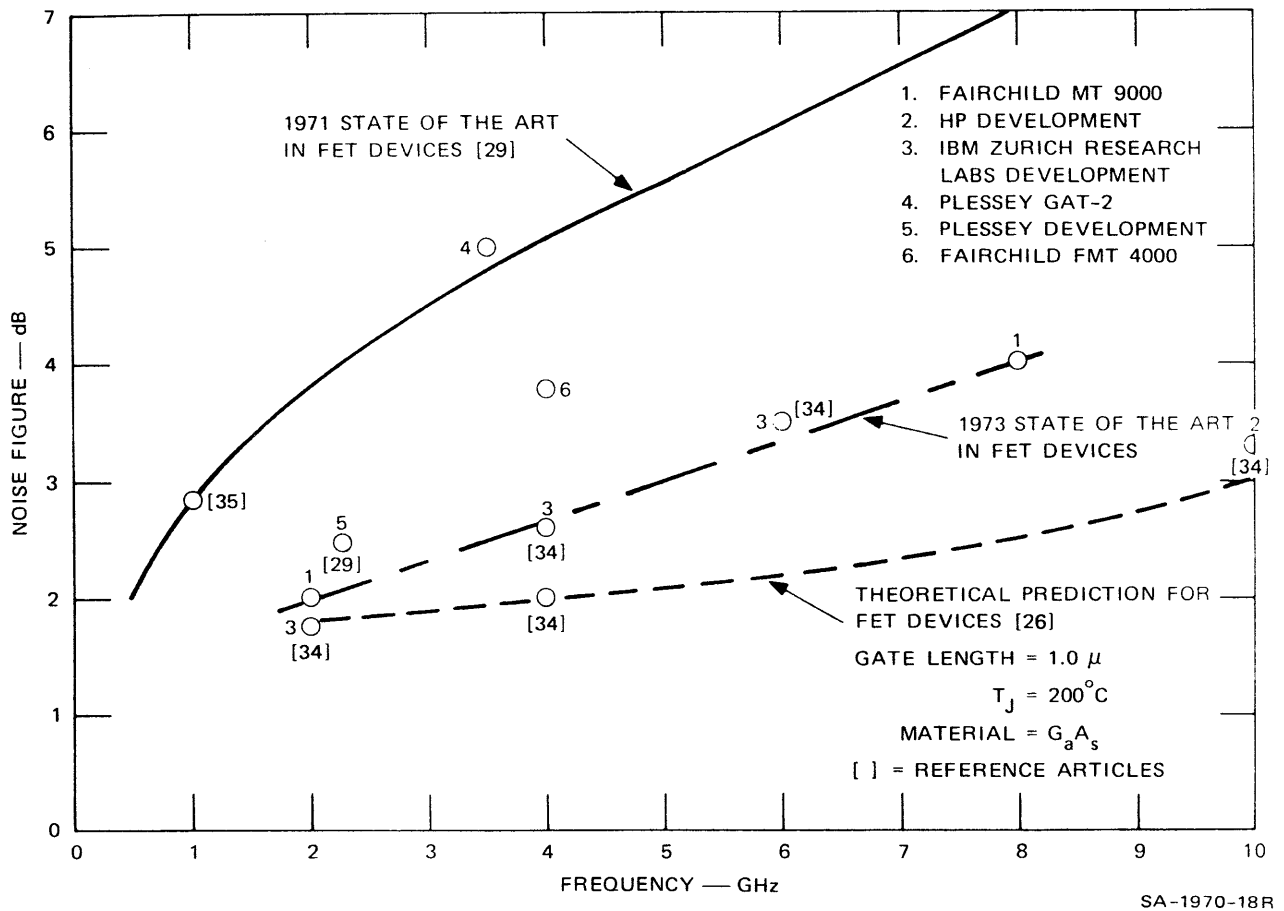

FIGURE VI-10 NOISE-FIGURE PERFORMANCE OF FET DEVICES — 1973

E. CONCLUSIONS

1. Comparison of Noise Figure of Low-Noise Devices

Low-noise front-end receivers can be designed using bipolar transistor amplifiers, field-effect transistor amplifiers, parametric amplifiers, or direct-converting mixers. Our main objectives in receiver design are simplicity and cost-effective techniques for maximum performance. Noise figure of a receiver determines the quality of a receiver. Calculations of noise-figure requirements with respect to frequency of operation for a particular beacon-transponder receiver will determine whether it is necessary to utilize preamplifiers in front of the mixer. There are many performance and cost tradeoffs in the receiver designs using preamplifiers in front of a mixer. In this project, receiver designs of this type were not considered or investigated, since the topic is complex and would require a separate study.

Noise-figure performance of state-of-the-art bipolar transistors, field effect transistors and mixer diodes have been compared. Results are shown in Table VI-5. At low and medium frequencies (≤ 8 GHz), field-effect transistors have a lower noise figure than mixer diodes. At higher frequencies, mixer diodes are still dominant as low-noise devices. This is primarily due to lack of development in FET devices. Eventually FET devices will compete with mixers in performance even at the higher frequencies.

Table VI-5. Comparison of Noise Figure for State-of-the-Art Bipolar Transistors, Field-Effect Transistors, and Schottky-Barrier Mixer Diodes

| Frequency (GHz) | Bipolar Transistor Noise Figure (dB) | FET Noise Figure (dB) | Schottky-Barrier Mixer-Diode Noise Figure (dB) |
|-----------------|--------------------------------------|-----------------------|--|
| 2 | 2 | 2 | 5.3 |
| 4 | 2.8 | 2.6 | 5.0 |
| 6 | 4.2 | 3.5 | 5.5 |
| 8 | Not Available | 4.0 | 5.5 |
| 12 | Not Available | 5.0 | 5.7 |
| 16 | Not Available | Not Available | 6.0 |
| 35 | Not Available | Not Available | 7.0 |

The mixer designs are more simple than the FET amplifiers or the bipolar transistor designs because less components are used. Therefore, for beacon-transponder application at any frequency, mixer front-end designs will be considered as long as the noise-figure requirements are not less than 6 to 7 dB.

2. Forecasts on Capabilities of Solid-State Devices

From review of the various articles and publications on solid-state devices, the following future technological developments are expected in the next three years.

- Transistors (bipolar silicon) will probably achieve 1 watt capability at X-band. Silicon power transistors have generated, on a laboratory basis, more than 5 watts CW at 4 GHz. Microwave Semiconductor Corporation, New Jersey, recently announced a 4-watt CW transistor at 4 GHz. Efficiencies for power transistor oscillators and amplifiers at high S- and low C-band exceeded 30%. Also, pulse power levels of 100 watts at 1 GHz have been achieved.
- Gallium arsenide IMPATTs will be able to generate 5 watts CW at X-band with efficiencies in excess of 20%. IMPATTs have produced in excess of 4 watts CW at 5 GHz in the laboratory.
- Gunn diodes will reach the 2- or 3-watt level at X-band with efficiencies better than 10% and with superior noise characteristics. Most Gunn diodes are considered for local-oscillator or low-noise transmitter applications.
- Silicon IMPATTs will be an important factor in the millimeter range, generating up to 1 watt of power at 100 GHz, and may well rival gallium arsenide IMPATTs for X-band power applications.
- TRAPATT and Gunn devices will have significant impact on low-average-power requirements.
- The FET technology, particularly that of gallium arsenide, will seriously threaten silicon bipolar transistors for power applications at frequencies above S-band and will dominate low-noise requirements at the higher-frequency ranges (C-band and above).

- All local-oscillator and low-power transmitter requirements are being satisfied by Gunn diode sources because they have substantially less noise than IMPATT diodes. For Gunn diodes, AM noise-to-carrier levels of -135 dB in a 100-Hz band, 10 kHz off the carrier have been achieved with corresponding FM noise of 1 Hz. GaAs IMPATTs have better noise characteristics than silicon IMPATTs. Recently the BARRITT IMPATT³⁶ diode was developed. Its noise characteristics are much better. The BARRITT diode is still in an infant stage of development.

REFERENCES FOR SECTION VI

1. J.M. Early, "Speed and Semiconductor Devices," *International Convention Record* (1962)
2. B.C. DeLoach, Jr., "Avalanche Transit Time Microwave Diodes," Chap. 15, *Microwave Semiconductor Devices and Their Current Applications*, H.A. Watson, ed. (McGraw-Hill Book Co., New York, N.Y., 1969).
3. A.R. Hutson, et al., "Mechanism of the Gunn Effect from a Pressure Experiment," *Phys. Rev. Letters*, Vol. 14, pp. 639-641 (April 19, 1965).
4. J.A. Copeland, "A New Mode of Operation for Bulk Negative Resistance Oscillators," *Proc. IEEE Letters*, Vol. 54, pp. 1479-1480 (October 1966).
5. Robert S. Ying, "X-Band Silicon Double Drift IMPATT Diodes Using Multiple Epitaxy," *Proc. IEEE Letters*, Vol 60., No. 9, pp. 1104-1105 (September 1972).
6. J.C. Irvin, D.J. Coleman, Jr., W.A. Johnson, I. Tatsuguchi, D.R. Decker, and C.N. Dunn, "Fabrication and Noise Performance of High-Power GaAs IMPATTs," *Proc. IEEE*, Vol. 59, pp. 1212-1215 (August 1971).
7. A. Mircea, A. Farrayre, and B. Kramer, "X-Band GaAs Diffused IMPATT Diodes for High Efficiency," *Proc. IEEE*, Vol. 59, No. 9, pp. 1376-
8. K. Kurokawa and F.M. Magalhaes, "An X-Band 10-Watt Multiple-IMPATT Oscillator," *Proc. IEEE*, Vol. 59, No. 1, pp. 102-103 (January 1971).
9. D.H. Lee, "Ion Implanted Double-Drift IMPATT Diodes: Low Frequency Noise," paper presented at International Electron Devices Meeting, Washington, D.C., December 4-6, 1972.
10. J.D. Adams, "Capability of a Projected 1975 Airborne Solid State Phase-Array Radar," *Microwave Journal* (September 1971).
11. R.E. Brown, "High Frequency Gunn OSC," paper presented at International Electron Devices Meeting, December 4-6, 1972.
12. T.S. Saad, *Microwave Engineers Handbook*, Vol. 2, p. 168 (Artech House, Inc., Dedham, Mass., 1971).
13. Fred Sterzer, "Transferred Electron (Gunn) Amplifiers and Oscillators for Microwave Applications," *Proc. IEEE*, Vol. 59, No. 8 (August 1971).
14. A.L. Edridge and J.J. Purcell, "High Power Q-Band (26-40 GHz) Pulse Gunn Oscillator," *Proceedings of the 1971 European Microwave Conference*, Vol. 1 (1971).
15. H. Hirayama, *Microwaves* (July 1971).
16. C. Hilsum and H.D. Rees, *Electronics Letters*, p. 277 (1970).

17. B.E. Berson, "Transferred Electron Devices," *Proceedings of 1971 European Microwave Conference*, Vol. 1 (1971).
18. L.F. Eastman, "The Capabilities and State of the Art of Gunn and LSA Devices," *1969 International Microwave Symposium Digest* (May 1969).
19. L.F. Eastman, "You Can Rely on LSA Diodes," *Microwaves* (December 1972).
20. L.F. Eastman, "High Average Power Pulse GaAs LSA OSC," paper presented at International Electron Devices Meeting, December 4-6, 1972.
21. B.S. Siegal, "Schottky Diodes - Where We Stand Today," *Microwaves*, Vol. 10, No. 4 (April 1971).
22. R.P. Rafuse, "Low Noise and Dynamic Range in Symmetric Mixer Circuits," *Proc. First Cornell Biennial Conference*, Cornell University, Ithaca, New York (August 19-31, 1967).
23. T.S. Saad, *Microwave Engineers Handbook*, Vol. 2, p. 164 (Artech House Inc., Dedham, Mass., 1971).
24. H.N. Ghosh, A.S. Oberai, M.B. Vora, J.J. Chang, M.L. Joshi, and T.H. Yeh, paper presented at IEEE International Electron Devices Meeting, Washington, D.C. (1969).
25. J. Archer, paper presented at IEEE International Electron Devices Meeting, Washington, D.C. (1971).
26. S. Kakihana, "Microwave Transistors, Bipolar and Field Effect - Today and Tomorrow," *IEEE G-MTT International Microwave Symposium Digest*, pp. 170-172 (May 22-24, 1972).
27. S. Kakihana, "Exact Noise Figure Model for Ultra Low Noise Microwave Bipolar Transistors," *IEEE International Electron Devices Meeting Digest*, p. 34 (December 4-6, 1972).
28. D.R. Chen, "A New Low-Noise Bipolar C-Band Transistor," *IEEE International Electron Devices Meeting Digest*, p. 36 (December 4-6, 1972).
29. R.T. Davies, "Front End Designs - Assaulting the Old Noise Barriers," *Microwaves*, Vol. 10, No. 4, pp. 32-36 (April 1971).
30. J.D. Adams, "Capability of a Projected 1975 Airborne Solid-State Phased Array Radar," *The Microwave Journal*, Vol. 14, No. 9 (September 1971).
31. M.H. White, "Microwave Bipolar Silicon Power Transistors," *IEEE International Electron Devices Meeting Digest*, p. 34 (December 4-6, 1972).
32. E.T. Ebersson, "L-Band Transistor Amplifier Diodes at 1 kW," *Microwaves*, Vol. 11, No. 12, p. 9 (December 1972).
33. J. Archer, "State-of-the-Art Small Signal Microwave Transistor," *Microwave Journal*, pp. 48-50 (February 1972).
34. R.T. Davies, "FETs Step Up to Low-Noise Microwave Applications," *Microwaves*, Vol. 11, No. 4, pp. 34-40 (April 1972).
35. J.A. Turner and S. Arnold, "Schottky-Barrier FETs - Next Low-Noise Designs," *Microwaves*, Vol. 11, No. 4, pp. 44-49 (April 1972).
36. Staff Report, *Microwaves* (June 1972).

VII. POWER-COMBINING TECHNIQUES

A. GENERAL

Different RF-power-combining techniques for oscillators and amplifiers were investigated as part of the study in order to determine the best scheme for obtaining the maximum RF power output at a particular operating frequency. Several methods exist for combining individual semiconductor devices (transistor or diode) to increase the total output power. Basically there are two groups – nonoptical, and quasi-optical. Various articles and reports published on the combining techniques were reviewed.¹⁻⁹ A summary of our findings is given in the following subsections.

B. NONOPTICAL COMBINING TECHNIQUES

In general, four classes of circuits exist for combining active devices (transistor or diodes) either as amplifiers or as oscillators. They are as follows:

- Series or parallel combinations of individual devices in the same device package; and series, parallel, or series-parallel arrays of packaged devices. Each device is usually separated by a length of transmission line.
- Cascaded transmission amplifier/oscillator
- Weakly coupled
- Strongly coupled

Of the combining circuits listed above, only the last two have the capability for combining a large number of individual source modules. Only a small number of semiconductor devices (5 to 10) can be assembled on the same substrate in the same package. If these devices are connected in parallel, the impedance becomes too small. If they are connected in series, the breakdown voltages become excessive and heat sinking can be a problem. In addition, the finite length between individual devices becomes important at higher frequencies. These same limitations apply to an array of packaged devices, with the additional complication of spurious oscillation being possible because of the line length.¹⁰ Stabilizing networks are required to suppress these oscillations. A typical method of connecting multiple varactor diodes in high-power multipliers is shown in Figure VII-1.¹⁰ In Ref. 10., the authors have shown how to achieve a high-power varactor doubler using a series-parallel array of eight individual varactor diodes. Experimental results show that design techniques for controlling instabilities are practical. Similar array techniques can be used for other types of active devices (e.g., direct-generating diodes and transistors). The instabilities may occur, but techniques for controlling them will be different. Generally, array

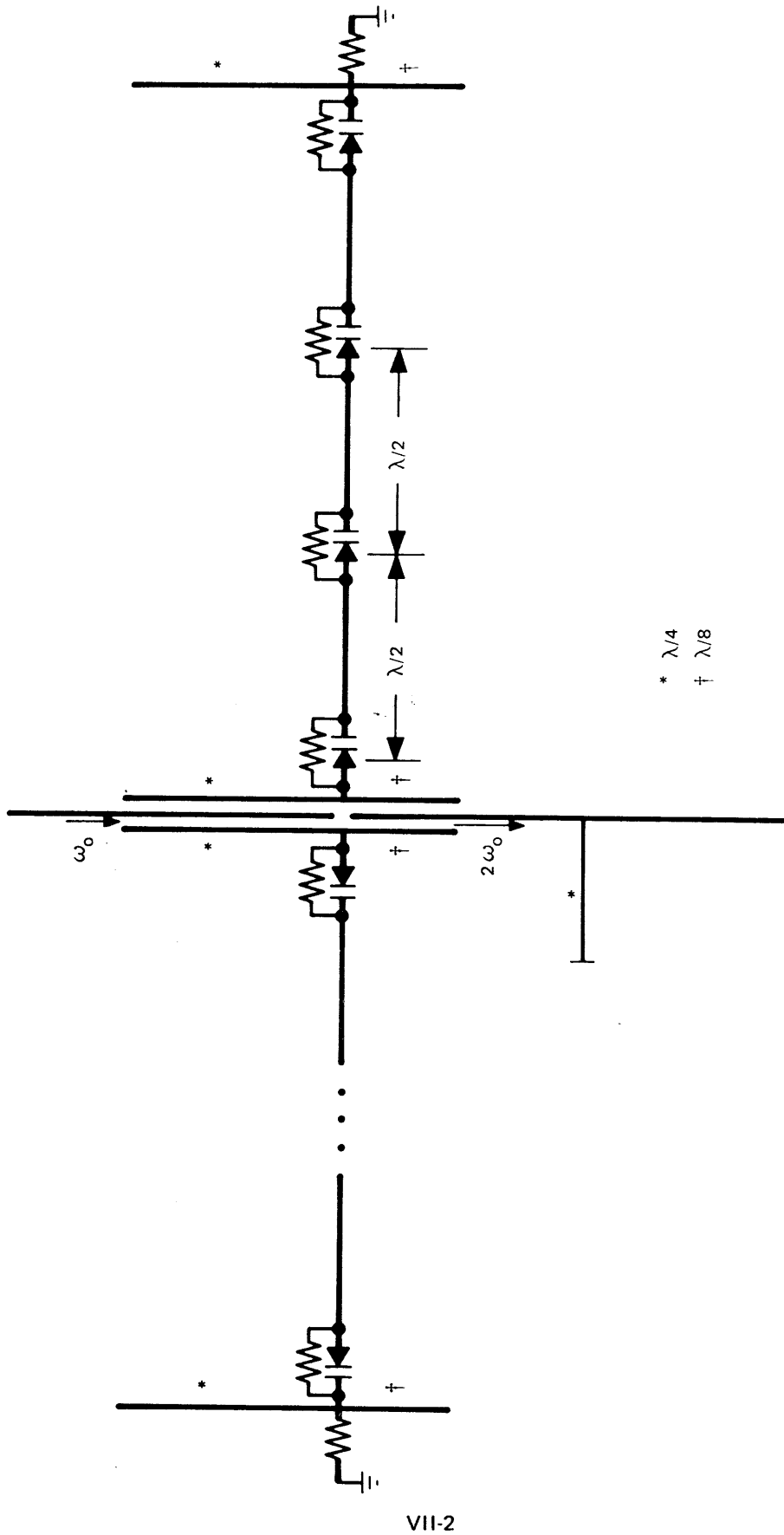

SA-1970-33

FIGURE VII-1 A SERIES-PARALLEL ARRAY OF EIGHT DIODES EACH WITH SELF-BIASING RESISTORS AND COUPLED LINE FILTERS AT THE INPUT AND OUTPUT FREQUENCIES

combining techniques are not used for direct-generating diodes, primarily because they are impractical. The reasons are as follows:*

- The efficiency of direct-generating devices (Gunn or IMPATT) is low, typically 5% to 15%, depending on the frequency of operation and circuit design. Due to this low efficiency, excessive heat is dissipated in the diode. As the number of diodes is increased, the heat dissipation is increased proportionally. Therefore heat sinking of series arrays of diodes is impractical. In comparison, varactor diodes used in the doubler circuits are capable of much higher efficiencies, typically 60% to 70% at E-band and 40% to 50% at I-band.
- An additional disadvantage of series-connected IMPATT diodes is the requirement of high voltage for biasing. A single, double-drift IMPATT diode requires 100 volts bias voltage at 14 GHz. In comparison, a small number of Gunn diodes can be connected in series, theoretically, if parasitics of the individual packages can be minimized. A single GUNN diode requires 12 volts bias voltage at 14 GHz.
- IMPATT or Gunn diodes are used practically for operation above 4 GHz (limitations are primarily due to the present material technology). The heat sinking problems can be overcome by paralleling the diodes. Paralleling large numbers of such active devices (applies to varactor diodes also) in an array can cause instabilities because of the parasitics due to the individual packages. Complex circuitry may be required to control the instabilities. To overcome this limitation, a small number of semiconductor chips are generally connected in parallel in one package. An advantage of the parallel connection of semiconductor chips is the graceful degradation of RF power when failures occur. (It is assumed that most of the failures in semiconductors cause the device to be open-circuited.)

Array combining techniques for high RF power can be used for transistors also. However, instability problems can exist due to package parasitics of a large number of parallel or series-connected transistors. To achieve high-power capability practically, multiple-emitter transistor construction is used. The maximum number of emitters in one semiconductor device is limited by the physical geometry and frequency of operation. If "n" number of devices are combined, then theoretically the maximum power output will be "n" times the power output of one device. For parallel-connected devices, graceful degradation is possible if any malfunction occurs.

1. Cascaded Transmission Amplifiers and Oscillators

The number of amplifiers or oscillators that can be cascaded before the saturation level of the individual active device is reached is small (5 to 10, typically). A typical cascaded amplifier and oscillator configuration is shown in Figures VII-2 and VII-3 respectively. As the power is increased in the individual modules, eventually a limit is reached in the power available from the active device in the last stage of the link. This limitation is due to the relationship $PXf^2 = \text{Constant}$ that all semiconductors obey. Also, the gain of the amplifier decreases as the power is increased. The semiconductor device used in the amplifier or oscillator modules can be either a transistor or a direct-generating diode. The selection of the device will depend on the frequency of operation and the power output required. The high-power cascaded source can

*Comments here apply mainly to IMPATT or Gunn diodes. TRAPATT and LSA diodes are not considered because of the complex circuitry that is required for proper operation, which is not economical for beacon transponders.

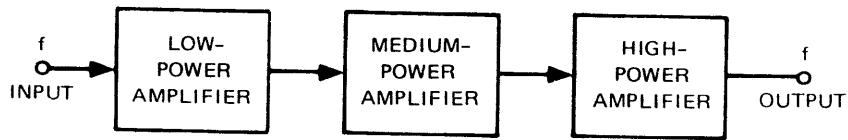

- AMPLIFIERS HAVE EITHER A DIRECT-GENERATING DIODE OR A TRANSISTOR.
- EACH AMPLIFIER CONTAINS ONE ACTIVE DEVICE.
- f IS FREQUENCY OF OPERATION.

SA-1970-21R

FIGURE VII-2 CASCADED TRANSMISSION AMPLIFIERS

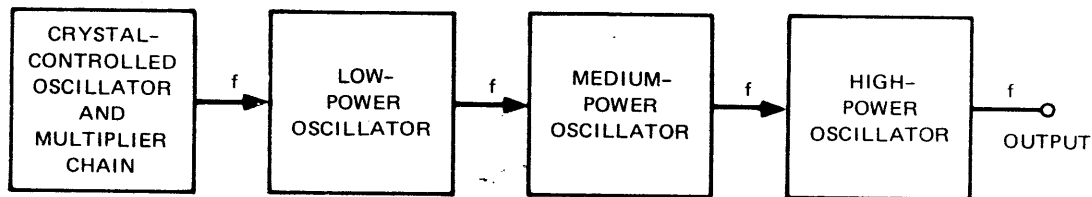

- OSCILLATORS ARE INJECTION PHASE-LOCKED.
- OSCILLATORS HAVE EITHER A DIRECT-GENERATING DIODE OR A TRANSISTOR.
- f IS FREQUENCY OF OPERATION.

SA-1970-22R

FIGURE VII-3 CASCADED TRANSMISSION OSCILLATORS

be fabricated with all the individual amplifier circuits or oscillator circuits in one module. With a large number of stages, however, instability will occur; therefore precautions have to be taken. Instabilities can be controlled in a small number of stages (5 to 10) either by proper circuit design or by the use of isolators. By taking advantage of the isolation that can be achieved with nonreciprocal properties of ferrites, Microwave Associates, Burlington, Mass., has built cascaded amplifier stages using IMPATT diodes at X-band on one ferrite substrate.⁴ Hughes Aircraft Company, on the other hand, has a periodic circuit currently under development that is a solid-state transmission amplifier. This particular amplifier uses IMPATT diodes in a coupled-cavity slow-wave structure in reduced-height waveguide. Such a structure can be designed so that each diode adds a fixed amount of power to the wave — that is, has a decreasing-gain-per-stage characteristic. This approach can permit a medium number of stages before instabilities occur, and presents a convenient way of adding power from several devices. Hughes Aircraft Company has reported theoretical and experimental results on one- and two-stage amplifiers indicating that 10% bandwidths with gains of 2.5 dB and 5.0 dB are obtainable in X-band. Increasing the number of these stages much beyond four or five is expected to be difficult because of stability problems.

2. Weakly Coupled Combining Circuit

Individual amplifiers or oscillators capable of independent operation are combined through the use of multiple-port circuits consisting of transmission lines and passive additive elements, such as couplers or hybrids (see Figure VII-4 for a typical amplifier combiner, or Figure VII-5 for a typical oscillator combiner). Nonreciprocal elements such as circulators or isolators may be incorporated for stability. This type of combiner is classed as weakly coupled. Either in-phase or quadrature hybrids can be used in the amplifier combining scheme. If quadrature hybrids are used, then the source modules have to be matched in phase and amplitude. However, for the multiple-oscillator combiner, in-phase hybrids only are used. (Quadrature-phase hybrids have a 90° phase shift.) In principle, any amount of power can be obtained in this way, but in practice the power output is limited by physical and economic factors. In particular, loss in the adders is a prime factor in limiting the power output of the systems. Because of this loss, heat is generated in each

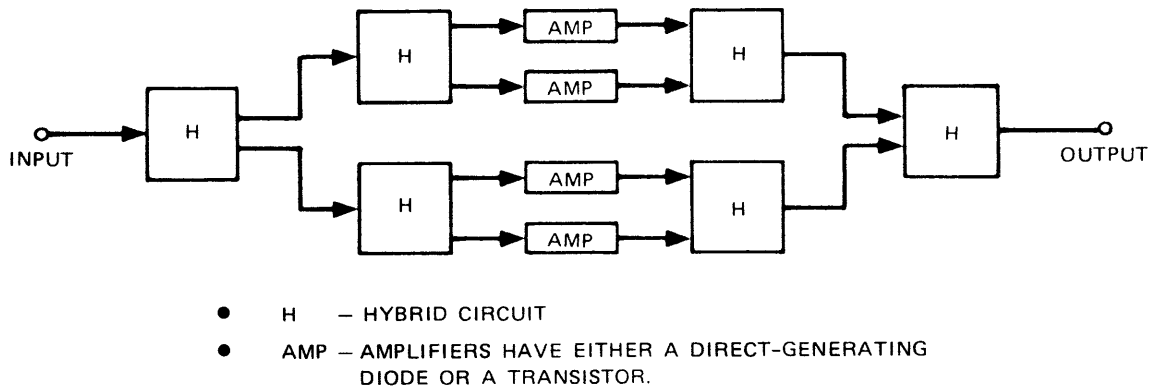

SA-1970-23R

FIGURE VII-4 POWER-COMBINER SCHEME FOR AMPLIFIERS USING HYBRIDS

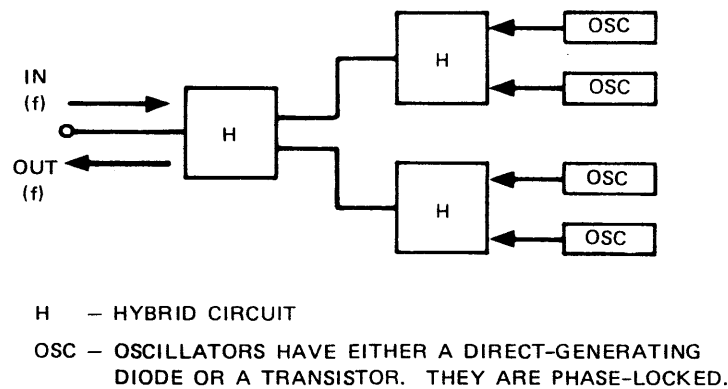

SA-1970-24R

FIGURE VII-5 POWER-COMBINER SCHEME FOR OSCILLATORS USING HYBRIDS

adder and the power output of the last stage will be limited by thermal-dissipation capabilities of that adder. Furthermore, if there is a requirement of efficiency for the system, the loss per stage limits the number of stages that can be used. If there is α dB loss in each power combiner and the minimum acceptable efficiency of the power-combining system is ϵ_{\min} , then the maximum number of stages that can be used is given by

$$n_{\max} \cdot \alpha \leq 10 \log_{10} \epsilon_{\min}$$

Figure 6 shows the theoretical value of n_{\max} as a function of α for several values of ϵ_{\min} . Power combiners are presently available with losses in the region shown in the figure. Waveguide combiners will offer the lowest loss — 0.2 dB per stage, typically — and microstrip and coaxial combiners have a loss of 0.3 dB to 0.5 dB, typically. Final values of loss will depend on the frequency of operation, mismatch loss, phase unbalance, and isolation in the hybrid. For large numbers of hybrid combiners, losses and balancing problems

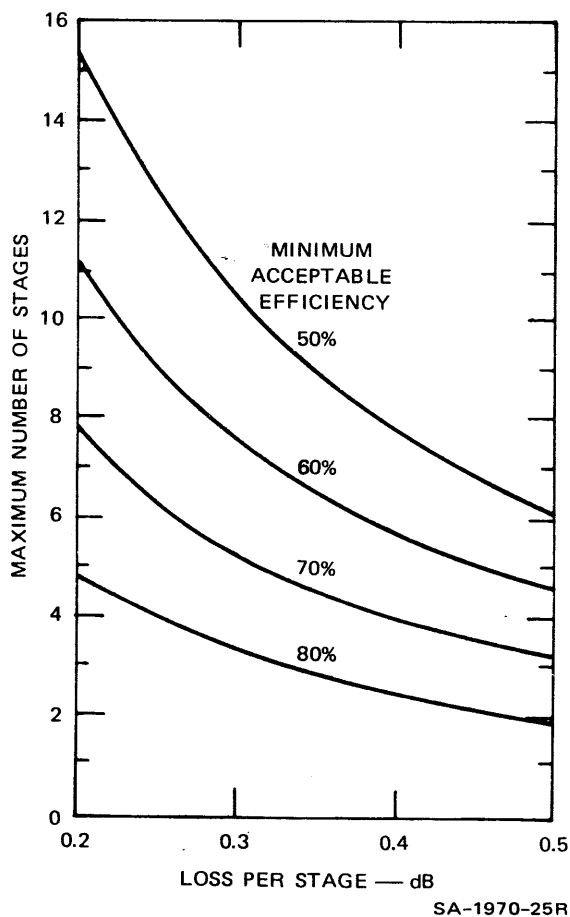

FIGURE VII-6 MAXIMUM NUMBER OF POWER-COMBINING STAGES FOR VARIOUS COMBINER LOSSES AND REQUIRED COMBINER EFFICIENCY. Source: Ref. 1.

become critical. The number of stages that can be used is shown in Figure VII-7 for a required system efficiency, as a function of device efficiency (amplifier or oscillator), of 25%, and various combiner losses. This assumes no phase unbalance or mismatch losses. Two organizations using such hybrid combining techniques have recently reported on the state of the art in high-power sources.^{11,12} The Electromagnetic Techniques Laboratory of Stanford Research Institute developed a high-power, reflection-type microwave amplifier.¹¹ This amplifier utilizes four individually matched silicon IMPATT diodes and a hybrid-circuit power-combiner scheme to achieve a CW output of 8 watts at 5.23 GHz with 6 dB gain and a power-added efficiency of over 5%. Subsequent to this work, a two-stage 15.8-watt-output 9-dB-gain amplifier was constructed which combined twelve silicon IMPATT diodes in a hybrid microstrip microwave circuit.

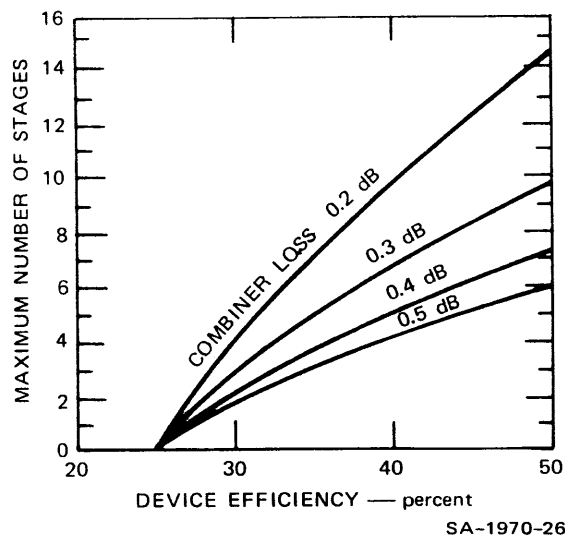

FIGURE VII-7 MAXIMUM NUMBER OF COMBINER STAGES FOR A REQUIRED SYSTEM EFFICIENCY OF 25 PERCENT. Source: Ref. 1.

Westinghouse, Baltimore, recently reported the development of an L-band transistor amplifier that is capable of 1 kW power output.¹² Using power transistors and a unique divider/combiner, they produced 1-kW/1-ms pulses at 1250 MHz in one subsystem module. Four 25-watt transistor-amplifier circuits were first combined to produce a 100-watt amplifier, then 12 of the 100-watt amplifiers were combined using hybrids to produce the full kilowatt. The 12 100-watt modules used in the amplifier are individually matched with ± 1 dB in amplitude and ± 7.5 degrees in phase.

3. Strongly Coupled Combining Circuit

In the case of the strongly coupled combiner circuit, a number of active negative-resistance elements or individual operating transistor-amplifier/oscillators are incorporated into a single amplifier or oscillator circuit. The immediate RF environment for each of the active elements is provided by the entire circuit, so that separate operation by the individual elements is not usually possible. A basic approach to strongly coupled circuits makes use of iterative power coupling in a transmission line. The principle of this

method is shown schematically in Figure VII-8 for a stripline circuit. The amplifiers or oscillators are coupled iteratively (capacitively or inductively) to the transmission lines. Stabilization of iterative amplifiers or oscillators may be accomplished externally with circulators, or internally by the use of distributed isolator elements. Such types of circuits are still in various stages in the industry.¹

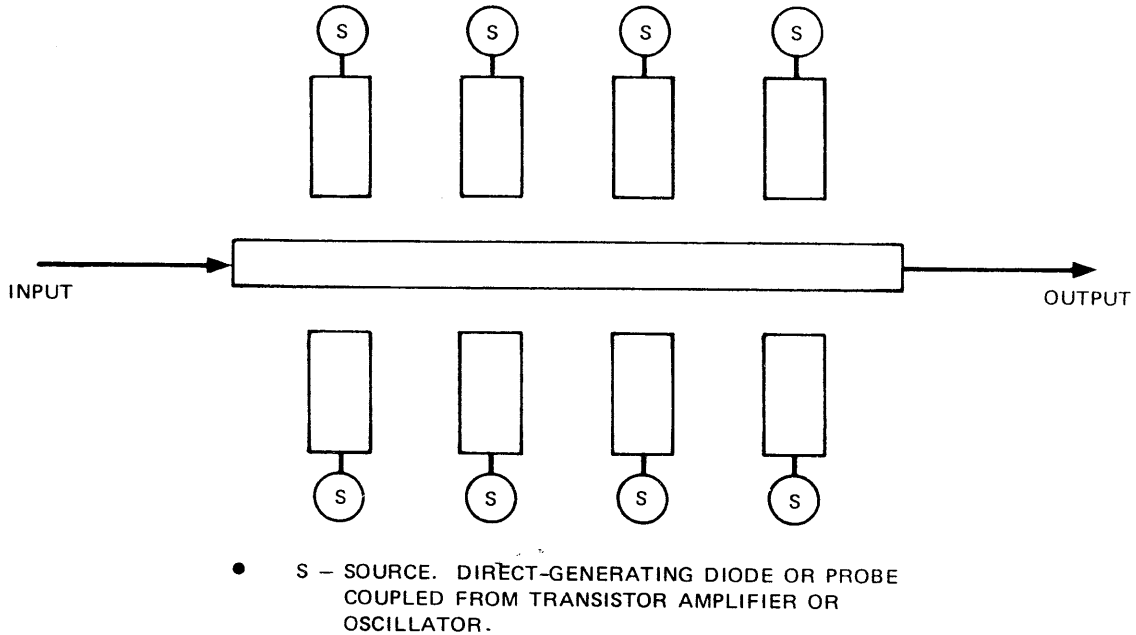

SA-1970-27

FIGURE VII-8 ITERATIVE POWER-COMBINER SCHEME FOR AMPLIFIERS AND OSCILLATORS

C. QUASI-OPTICAL COMBINING TECHNIQUES

A well-known optical technique for the accumulation of microwave power from a large number of modular sources (transistor or direct-generating diodes) is the phased-array antenna. This technique will allow combining of the largest number of sources with the smallest possible number of higher-order modes because the space combiner is not a closed volume. If mutual-coupling effects between the sources are neglected, then each source is independently coupled to the impedance of free space. By proper phasing of the inputs in the sources, power can be focused into a collecting horn or probe, some distance away. In Figure VII-9, sketches of two types of closed-volume single-cavity power combiners using the phased-array techniques are shown. However, unless the dimensions of the array are large and the source power levels are properly tapered, diffraction loss can occur. An extension of this approach would be a linear array wrapped in a circle or ellipse. This arrangement would now allow all the power sources to operate at equal levels. A circular combiner or radial-type cavity is shown in Figure VII-10 and an elliptical combiner is shown in Figure VII-11. Both these combiners have been developed at Hughes Aircraft Company.^{1,3} Recently, it was reported that 32 IMPATT diodes were combined in a radial cavity to achieve 23.4 watts of CW power at 9.3 GHz.³ The power combiner uses commercially available IMPATT diodes nominally rated at 500 mW. Each of the diodes is mounted in a coaxial module, magnetically coupled to a TM₀₂₀ microwave cavity. To accommodate the 32 diodes around the cavity, the periphery of the cavity must be made

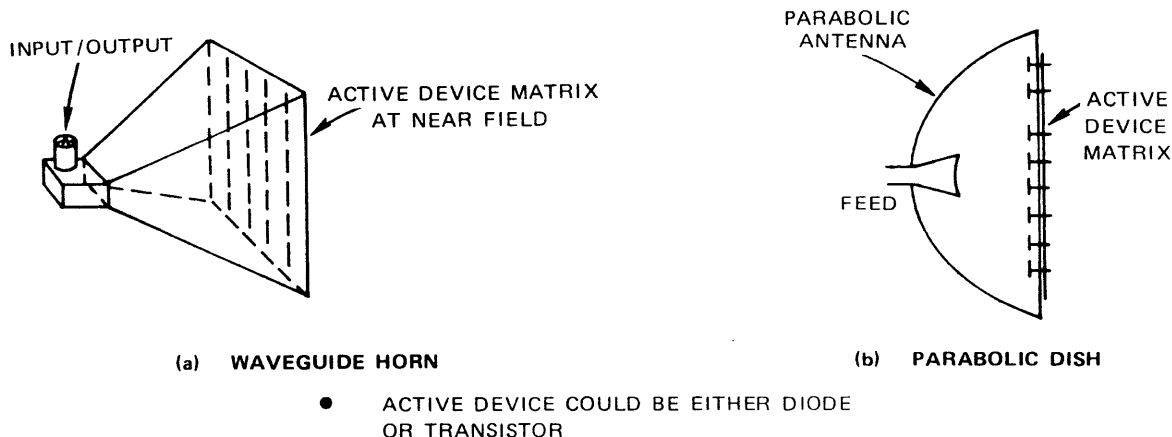

SA-1970-28

FIGURE VII-9 CLOSED-VOLUME PHASED-ARRAY COMBINER

so large that the cavity becomes over-moded. To obtain coherent operation, therefore, a mode filter is used in the cavity to suppress the unwanted modes. The combiner does not require that the diodes be spaced an integral multiple of half wavelengths. Packing density is limited only by the physical size of the packaged diode. The individual diodes are matched to the high impedance of the resonant cavity by an impedance transformer.

An L-band radial power combiner has been developed at SRI for eventually combining multiple 100-watt transistor amplifiers. Studies are being performed on bandwidth, isolation between various ports, insertion loss, and mode suppression. In this particular radial power combiner the size of the cavity was chosen to combine power from several different ports (maximum of 30) with only the fundamental mode being existent. Such a design technique is applicable for lower frequencies because the linear dimensions of the cavity are small compared to a wavelength. There is a practical and fundamental limit to the number of devices or probes that can be added in a cavity of a given size and still maintain a fundamental mode of propagation with no higher-order modes. A serious disadvantage of both the radial and ellipse combiner at high frequencies is that, since these structures are large compared to a wavelength, several radial-mode resonances would exist. These resonances can lead to potential instabilities and spurious oscillation in the combiner. Mode suppressors are required, which, without careful design, would introduce considerable loss into the dominant mode.

D. CONCLUSIONS

In the previous subsections, different types of power combiners were discussed in general. Both the nonoptical and the quasi-optical scheme were covered. This subsection summarizes the types of combiners and active devices that could be used to fabricate low-cost beacon transponders for target-enhancement purposes at various power levels.

After a review of all the types of combiner schemes that exist, the following were found to be practical and feasible:

- Series or parallel, or a combination of both types
- Weakly coupled or hybrid circuits
- Cascaded transmission amplifier/oscillator
- Radial.

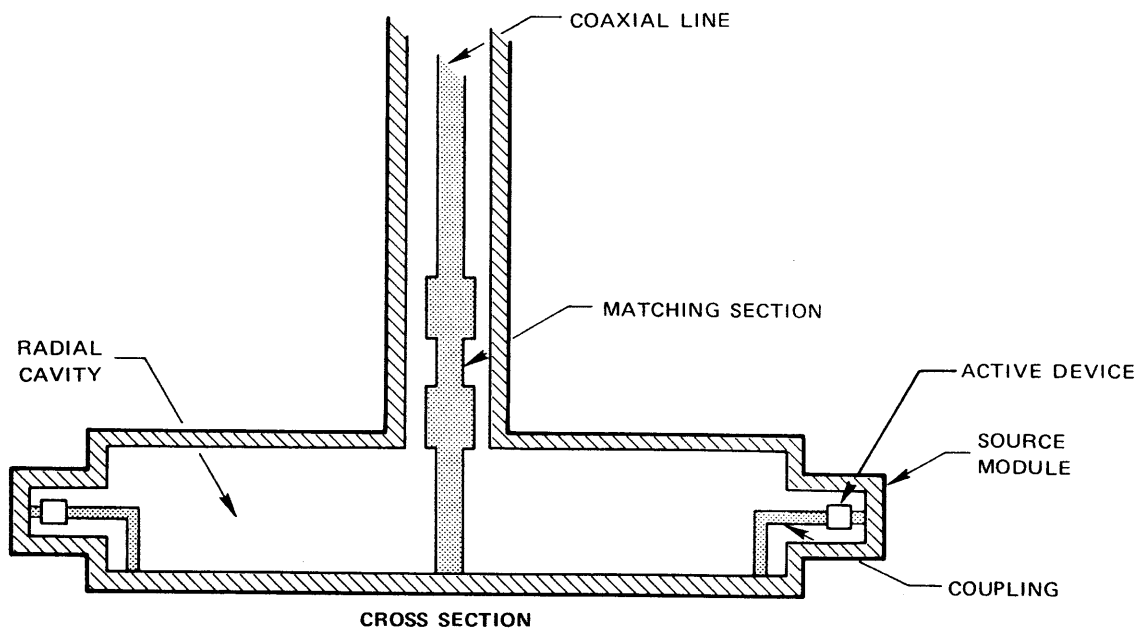
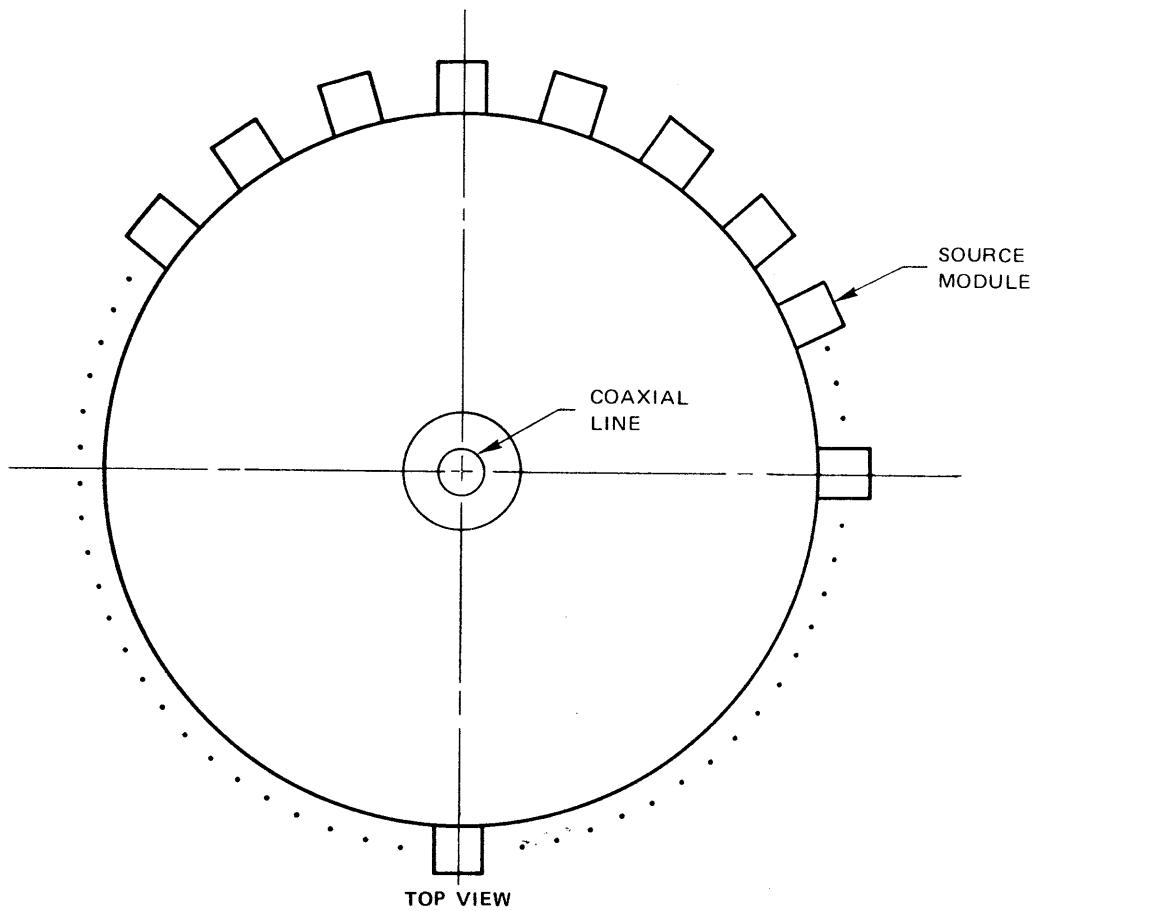

- ACTIVE DEVICE COULD BE EITHER DIODE OR TRANSISTOR

TA-651583-200

FIGURE VII-10 RADIAL-CAVITY COMBINER

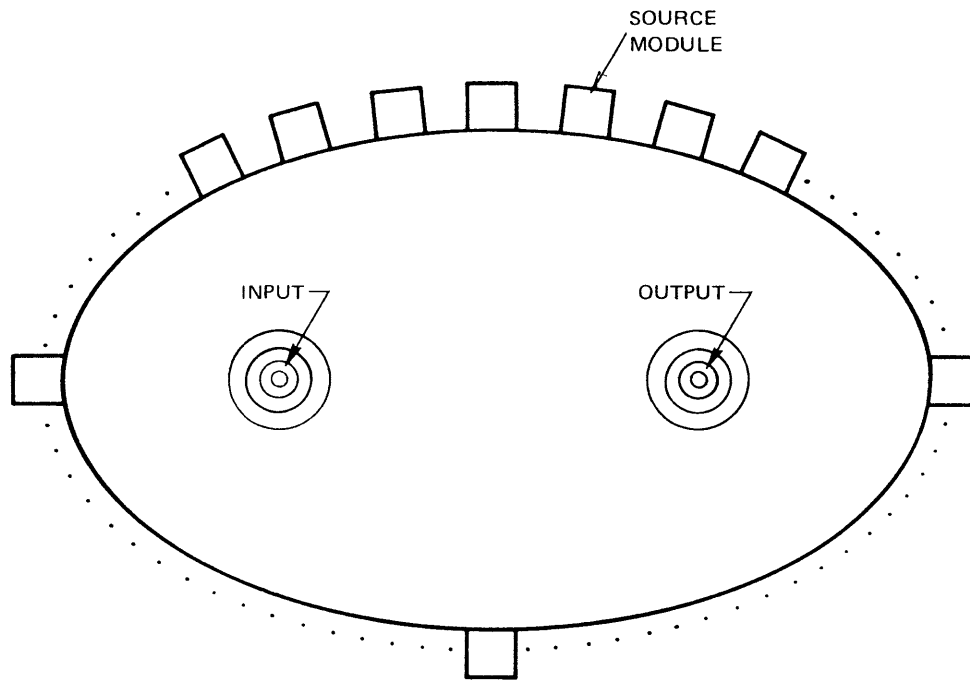

TOP VIEW

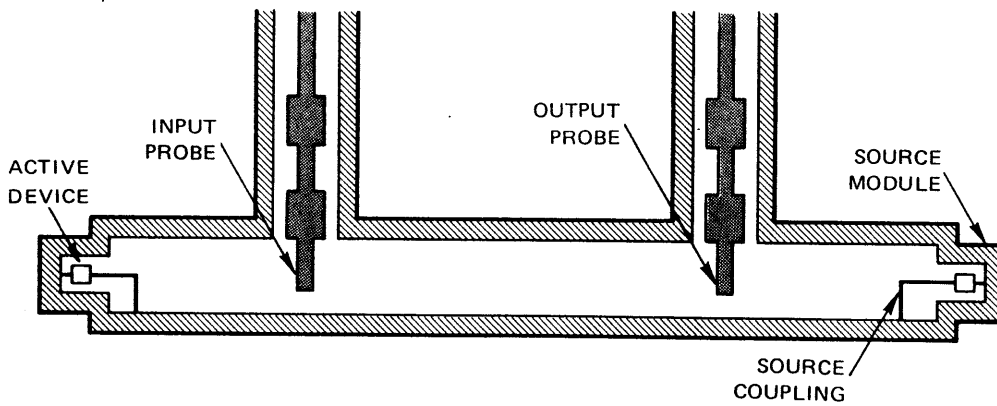

CROSS SECTION

- ACTIVE DEVICE IS DIRECT-GENERATING DIODE

TA-651583-201

FIGURE VII-11 ELLIPTICAL-CAVITY COMBINER

The other types are still in the early stages of development and therefore are not applicable for low-cost construction. A summary appraisal of all the combining techniques and their present status is given in Table VII-1.

Table VII-1. Summary of Power-Combining Techniques
For High-Power Beacon-Transponder Application

| Technique | Appraisal | Status |
|--|--|--|
| Nonoptical Series or parallel combination of active devices | Very complex for large numbers. For 2 to 4 devices, this technique can be applied. Broad bandwidths can be achieved with proper circuitry. Matching problems become difficult beyond I-band (8–10 GHz). Offers graceful degradation only for parallel technique. (This is true only if the device is open circuit on failure.) | Practically feasible for low- and medium-power levels – i.e., 2 to 4 times power of single device can be achieved. Applicable for D, E, G, I, J, and K bands at medium cost. |
| Cascaded transmission amplifiers/oscillators | Saturation limit depends on the power output of the last stage. Spurious oscillations become a problem beyond G-band (4–6 GHz). Development presently is only for narrow bandwidth. Offers no graceful degradation. | Practically feasible for low- and medium-power levels. Applicable for D, E, G, I, J, and K bands at medium cost. |
| Weakly Coupled | Very complex for large number of sources. Losses and balancing problems become critical for large number of sources. Octave bandwidths are feasible. Offers no graceful degradation. | Practically feasible for low- and medium-power levels – i.e., 5 to 10 times power of single device can be achieved. Applicable for D, E, G, I, J, K bands at low cost. |
| Strongly coupled | Either coupling or impedance, or both, must be tapered to prevent saturation at low levels. Stabilization is difficult. Technique suitable for large number of stages. High power can be achieved. Offers graceful degradation. | In early development phase. Applicable for D, E, G, I, J, and K bands at high cost. Premature to judge the overall capability of the technique. |
| Quasi-Optical Radial | Promising approach. Large number of devices can be combined. Spurious modes can exist. High power can be achieved. N-times single-device power is possible. Offers graceful degradation. | In early development phase. Applicable for D, E, G, I, J, and K bands at medium cost. Size will be large at D and E bands. |

Table VII-1. Summary of Power-Combining Techniques
For High-Power Beacon-Transponder Application (continued)

| Technique | Appraisal | Status |
|---------------------------------|---|---|
| Ellipse | Promising approach. Large number of devices can be combined. Spurious modes can exist. Stabilization could be more difficult than for radial. High power can be achieved. N-times single-device power is possible. Offers graceful degradation. | More research and development is required. Applicable for D, E, G, I, J, and K bands at medium cost. Size will be large at D and E bands. Premature to judge overall capability of the technique. |
| Phased array (closed volume) | Promising approach. Large number of devices can be combined. Spurious modes can exist. Stabilization could be more difficult than for radial. High power can be achieved. N-times single-device power is possible. Offers graceful degradation. | More research and development is required. Applicable for D, E, G, I, J, and K bands at medium cost. Size will be large at D and E bands. Premature to judge overall capability of the technique. |

Our discussion in Section VII-B and VII-C covered both oscillator and amplifier combiners. However, for the higher-power beacon-transponder designs considered on this contract, amplifier-combiner schemes are more suitable because pulse-modulated RF signals are to be transmitted. High-power oscillator designs using multiple active devices cannot presently be modulated easily for narrow pulsewidth because the frequency of oscillation of each active device may be different during the rise and fall time and will require some settling time. Since pulsewidths being considered are in the range of 20 to 100 ns, coherent frequency of transmission will not occur without complex circuitry and synchronization of pulse voltage to each active device.

Three different types of low-cost beacon-transponder designs recommended for target enhancement are shown in Figures VII-12, VII-13, and VII-14 for low-, medium-, and high-power application. The transponder is referred to as a low-power type when one high-power active device is used; as a medium-power type when a few high-power active devices are used in one circuit; and as a high-power type when multiple high-power active devices are used in a combiner circuit. In the case of medium-power application, a pulse oscillator is followed by a switch that is used for obtaining fast rise- and fall-time pulse response. For higher-power applications the medium-power circuit is used, followed by a high-power amplifier. This technique avoids the use of a high-power switch that would be required if a high-power oscillator were used. Table VII-2 summarizes the different types of practical combiner circuits recommended for use in the transponders for low-, medium-, and high-power applications. A comparison of transponders for different frequency bands is also considered in the same table. It has been assumed that transistor circuits will be used in the transmitter for D and E frequency bands, and IMPATT diode circuits will be used for G, I, J, and K bands.

A review was made of the various active devices that could be used in the transponder design. Based on the design goals (i.e., cost, size, efficiency, and availability of state-of-the-art devices), it appears that transistor and IMPATT diodes are most suitable for this application. All the active devices are summarized in Table VII-3.

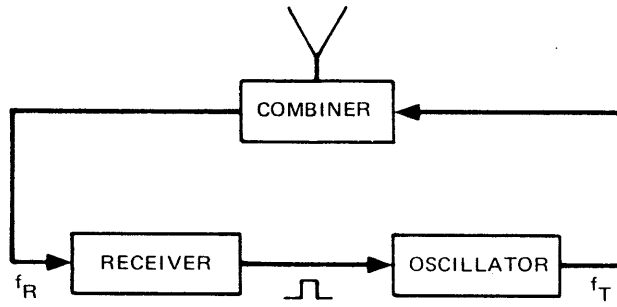

SA-1970-29

FIGURE VII-12 LOW-POWER BEACON TRANSPONDER

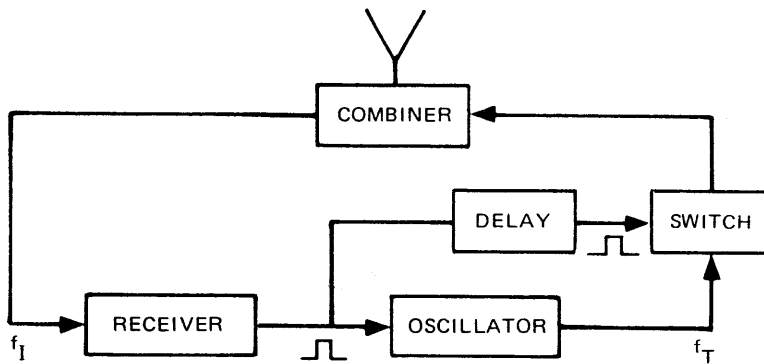

SA-1970-30

FIGURE VII-13 MEDIUM-POWER BEACON TRANSPONDER

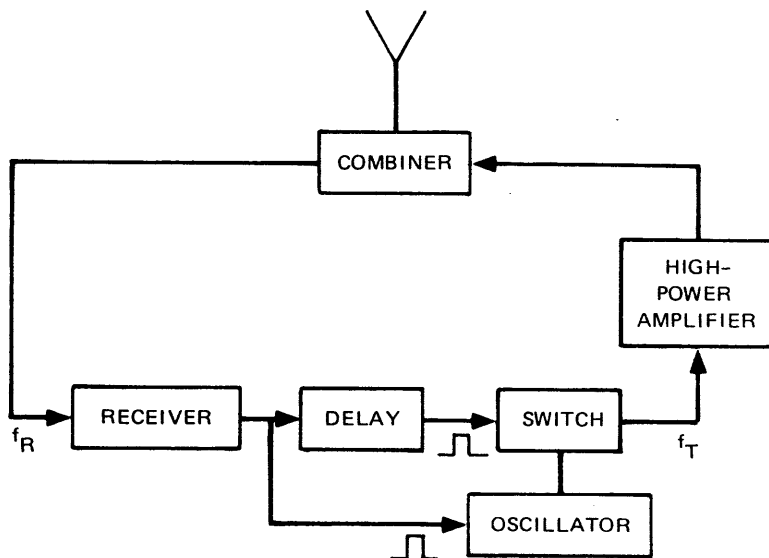

SA-1970-31

FIGURE VII-14 HIGH-POWER BEACON TRANSPONDER

Table VII-2. Practical Combiner Techniques for Beacon Transponder

| Frequency Bands | Output Power | | |
|-----------------|---|---|---------------------------|
| | Low | Medium | High |
| D (1–2 GHz) | High-power transistor or cascaded transmission stages | Series or parallel, or combination of series and parallel transistors | Hybrid combiner or radial |
| E (2–3 GHz) | High-power transistor or cascaded transmission stages | Series or parallel, or combination of series and parallel transistors | Hybrid combiner or radial |
| G (4–6 GHz) | High-power IMPATT or cascaded transmission stage | (a) Parallel, combination of IMPATTs* (b) Hybrid combiner | Hybrid combiner or radial |
| I (8–10 GHz) | High-Power IMPATT or cascaded transmission stage | (a) Parallel, combination of IMPATTs* (b) Hybrid combiner | Hybrid combiner or radial |
| J (10–20 GHz) | High-power IMPATT or cascaded transmission stage | (a) Parallel, combination of IMPATTs* (b) Hybrid combiner | Radial combiner |
| K (20–40 GHz) | High-power IMPATT or cascaded transmission stage | (a) Parallel, combination of IMPATTs* (b) Hybrid combiner | Radial combiner |

*Parallel combination may be done in one package or by separating the individual diodes by a half wavelength. Heat-sinking requirements will determine the practical selection.

Table VII-3. Review of Solid-State Devices for High-Power Combiners Used in Beacon Transponders

| Device | Appraisal |
|---|---|
| Transistors | Presently suitable up to 4 GHz. As technology advances, higher-frequency operation will be feasible. Small-size low-cost circuitry is feasible for beacon transponders. |
| IMPATT diode | Suitable for frequencies above 4 GHz. High-peak-power capability is feasible. Very suitable for beacon-transponder application. Efficiency is low (5%–15%). However, eventually higher efficiency is feasible. Small-size low-cost circuitry is feasible. |
| TRAPATT diode | Most promising device. High efficiency and peak power levels near 100 watts expected at X-band. The circuitry is complex. Unsuitable for a low-cost beacon transponder application at the present. |
| Harmonic generator (varactor diode multipliers) | Low-power complex circuitry. Unsuitable for low-cost beacon transponder. Useful for crystal-controlled sources. |
| GUNN diode | Modest efficiency, low power, about 1 watt CW at X-band. Useful for beacon-transponder application as low-power-level oscillator. Small-size low-cost circuitry is feasible. |
| LSA | High power, but very limited duty factors. The circuitry is complex. Unsuitable for low-cost beacon-transponder application at present. |

REFERENCES FOR SECTION VII

1. "Final Engineering Report for Super-Power Solid State X-Band Source Study," Report No. P70-99, HAC Reference No. B9415, Hughes Aircraft Company, Culver City, Calif. (March 1970).
2. "Interim Development Report for 11 kW Peak-Power Solid-State I-Band Amplifier," Contract No. N00039-72-C-0207, Project No. XF-52545011, Sperry Rand Corp. (September 1972).
3. R.S. Harp and H.L. Stover, "Power Combining of X-Band IMPATT Circuit Modules," *International Solid-State Circuits Conference Digest of Technical Papers*, pp. 118-119 (February 15, 1973).
4. R.N. Wallace and M.E. Hines, "Distributed Unidirectional Microwave Amplification," *Digest of Papers, International Microwave Symposium*, pp. 88-89 (May 1971).
5. V. Kaneko et al., "Multi-Parallel Operation of Gunn Diodes for High RF Power," *Digest of Papers, International Microwave Symposium*, pp. 156-157 (May 1971).
6. C.T. Rucker, "A Multiple Diode High-Average-Power Avalanche Diode Oscillator," *IEEE Trans., MTT-17*, No. 12, pp. 1156-1158 (December 1969).
7. K. Kurokawa, "An Analysis of Rucker's Multiple-Device Symmetrical Oscillator," *IEEE Trans., MTT-18*, No. 11, pp. 967-969 (November 1970).
8. K. Kurokawa and F.M. Magalhaes, "An X-Band 10-Watt Multiple IMPATT Oscillator," *IEEE Proc. Letters*, Vol. 59, No. 1, p. 102 (January 1971).
9. K. Kurokawa, "The Single-Cavity Multiple Device Oscillator," *IEEE Trans., MTT-19*, No. 10, pp. 793-801 (October 1971).
10. D. Parker and A.I. Grayzel, "A Stable Frequency Doubler Using a Series Parallel Array of Eight Diodes," *Proc. IEEE*, Vol. 58, No. 3, pp. 481-482 (March 1970).
11. R.E. Lee, D. Parker, and U. Gysel, "A High Power, C-Band Multiple IMPATT Diode Amplifier," presented at 1973 IEEE-GMTT International Microwave Symposium, University of Colorado, Boulder, Colo., June 4, 5, 6, 1973.
12. E.T. Ebersol, "L-Band Transistor Amplifier Dishes out 1 kW," *Microwaves*, Vol. 11, No. 12, p. 9 (December 1972).

VIII. PRODUCTION COSTS OF COOPERATIVE BEACON TRANSPONDERS

A. GENERAL

Two conceptual schemes of the cooperative beacon transponder at Ku-band (14.5 GHz) were considered for detailed production cost analysis. Preliminary cost analysis was also performed for the transponder at 24 GHz. One of the schemes is based on the design concepts discussed in Section V. Refer to Figure V-1 for details. In this concept, the diode detector was used in the receiver. The diode-detector sensitivity is limited and cannot be used for a range of 5 miles in 16 mm/hr rain when an ASD (T.I.) radar is being used. The second scheme is similar to the first scheme except that a more sensitive receiver is used. The latter scheme will achieve the required range of 5 miles in 16 mm/hr rainfall with an SNR of 13.8 dB when used with the ASD (T.I.) radar. A mixer pumped with a Gunn diode oscillator was used in the front of the receiver for down-conversion. Details of this scheme are shown in Figure VIII-1. In both schemes the power-supply system is an integral part of the overall design concept and is considered in the cost analysis. An RF switch at the output of the IMPATT diode oscillator is shown in both block diagrams. These switches may be necessary if fast-switching IMPATT diode oscillators with pulsewidths of 40 ns are not practically feasible and if high efficiency is not obtainable. Further extensive design and developments in the IMPATT diode oscillator and current modulator are necessary before a decision on the final technique can be made.

A pre-production design, development, and testing program is necessary before either of the two schemes is ready for final low-cost production. Also, field tests with ASD radar, environmental tests, temperature tests, and failure analysis must be performed before production can be started.

It is expected that after the nonrecurring preproduction design, development, and testing is fully performed, low-cost production techniques will be possible and could be applied in assembling the beacon transponder. Microwave integrated circuits will be used for all the microwave components where low-Q circuits are required. If high-Q circuits are required, coaxial or waveguide techniques may be used. By proper design techniques, it may be possible to use planar techniques for low cost. Hybrid integrated circuits will be used for all the IF, video, current-controller, and power-supply subsystems. Standard low-cost digital-logic-circuit techniques will be used in constructing and assembling the signal-processing system. Printed-circuit-board techniques will be used for all low-frequency circuits to reduce assembly and testing costs to the minimum.

Assuming that the production designs of the beacon transponder utilize planar techniques for both RF and low-frequency circuits, then the present-day production budget estimates are as given below.

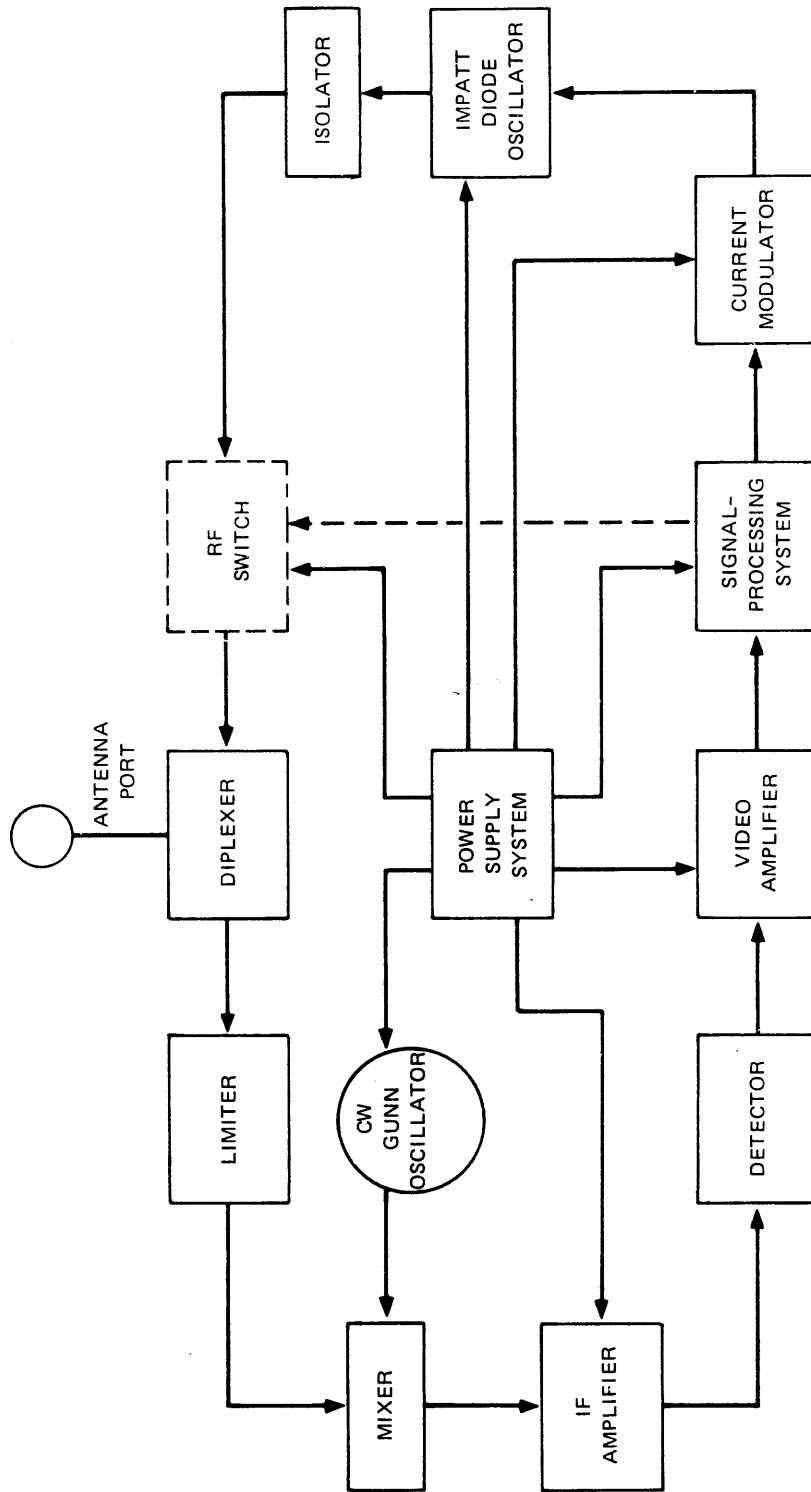

● DASHED BLOCK INDICATES A COMPONENT THAT MAY BE REQUIRED. FINAL DECISION WOULD DEPEND ON PREPRODUCTION DEVELOPMENT OF IMPATT DIODE OSCILLATOR.

SA-1970-46

FIGURE VIII-1 PROPOSED CONCEPTUAL BLOCK DIAGRAM OF HIGH-SENSITIVITY COOPERATIVE BEACON TRANSPONDER USED IN PRODUCTION QUANTITIES

B. SMALL-QUANTITY PRODUCTION-COST BUDGET

1. Ku-Band Beacon-Transponder Scheme using a detector front end

Labor and material costs for the Ku-band beacon-transponder scheme shown in Figure V-1 are as follows:

● Labor Costs (each unit)

| | | |
|--|-----------|-------|
| Total assembly (bonding, wiring, layout, etching, soldering), 16 hrs at \$5/hr | \$ 80 | |
| Testing, 4 hrs at \$6/hr | 24 | |
| Shipping, potting, and painting, 4 hrs at \$4/hr | <u>16</u> | |
| | \$120 | |
| Overhead (1.30 X actual cost) | | \$156 |

● Material Costs (each unit)

| | | |
|-----------------------------|-----------|--|
| Detector diode (1) | \$ 6 | |
| Limiter diode (1) | 5 | |
| Switching diodes (2) | 8 | |
| Switching-diode drivers (1) | 25 | |
| IMPATT diode (1) | 200 | |
| Isolator (plug-in type) (1) | 50 | |
| Low-frequency diodes | 4 | |
| Transistors | 5 | |
| Capacitors | 5 | |
| Resistors | 4 | |
| Digital integrated circuits | 5 | |
| Feedthrough | 3 | |
| Sundry | 3 | |
| Raw materials | 2 | |
| Mechanical box | <u>25</u> | |
| | \$350 | |

- Total Costs

- Labor Costs

- Direct \$120.00

- Overhead 156.00

- Material Costs 350.00

- Total \$626.00

- G and A costs at 25% 156.50

- Total \$782.50

- Profit at 10% 78.25

- Total Selling Price by Manufacturer \$860.75

The overall selling price will be lower by approximately \$100 if the RF switch is not used at the output of the IMPATT diode oscillator.

2. Ku-Band Beacon-Transponder Scheme using a mixer front end

This scheme, shown in Figure VIII-1, is similar to the scheme described above except for the additional mixer, Gunn diode oscillator, and IF amplifier in the circuit. Labor cost for production is not expected to increase much; however, the material costs will be increased due to the use of state-of-the-art semiconductors.

Total loaded cost increases are expected to be \$150. Therefore, the overall selling price in small quantities will be \$1,010.75 each. The overall selling price will be lower by approximately \$100 if the RF switch is not used at the output of the IMPATT diode oscillator.

C. LARGE-QUANTITY PRODUCTION-COST BUDGET ESTIMATES

1. Ku-Band Beacon-Transponder Scheme using a detector front end

The large-quantity production costs of the Ku-band beacon-transponder schemes shown in Figure V-1 are as follows:

| <u>Cost per Unit</u> | <u>Quantity</u> |
|----------------------|-----------------|
| \$700 | 100-199 |
| 575 | 200-499 |
| 500 | 500-999 |
| 450 | 1000-4999 |
| 400 | ≥ 5000 |

2. Ku-Band Beacon-Transponder Scheme using a mixer front end

The large-quantity production costs of the Ku-band beacon-transponder scheme shown in Figure VIII-1 are as follows:

| <u>Cost per Unit</u> | <u>Quantity</u> |
|----------------------|-----------------|
| \$800 | 100–199 |
| 625 | 200–499 |
| 550 | 500–999 |
| 500 | 1000–4999 |
| 450 | ≥ 5000 |

D. CONCLUSIONS

From the above cost analysis it can be concluded that the materials costs are high primarily because of the use of presently high-priced state-of-the-art IMPATT diodes and other microwave devices. As the technology advances and the supply of the microwave components increases, eventually prices will drop considerably. It is expected that Ku-band IMPATT diode prices will drop by \$100 or more for small-quantity purchases within the next year. This decrease will reduce the cost estimate by about \$135 per unit when ordered in small quantities, for the two schemes.

The above cost estimates can also be used in evaluating costs estimates for the 24-GHz cooperative transponder. It is expected that the materials cost for the microwave components at 24 GHz will be higher than at Ku-band. Also, the testing and assembly procedures will be more critical and time-consuming. Assuming for purposes of discussion and evaluation that a single IMPATT diode oscillator delivering 2 to 3 watts at 24 GHz is sufficient for target enhancement, it can be shown that the cost increase in fabricating a 24-GHz beacon transponder is expected to be 15% to 20% (in small quantities) above the cost of the Ku-band beacon transponder discussed. These results were based on preliminary calculations. A further detailed analysis is required to estimate the production costs and conceptual designs on the 24-GHz beacon transponders.

IX. RECOMMENDATIONS FOR FUTURE STUDIES AND DEVELOPMENTS

A complete consideration of the system aspects of using ASD radar enhancement techniques was beyond the scope of this contract. It is highly recommended that future detailed studies be performed on the practical implementation of target-enhancement techniques to achieve a fail-safe detection system at the airports that can be used to identify small or large airplanes, vehicles, runways, and stationary buildings. Also, studies should be performed on techniques to reduce the ground clutter by frequency-discrimination techniques.

In specific terms, the following topics on ASD radar systems are recommended for future investigations:

- Sidelobe-suppression techniques.
- Multipath propagation effects in airport or terrestrial environments.
- Reduction in clutter due to ground and rain.
- Encoding and decoding in beacon transponders used for target-enhancement purposes. Discrete address system.
- Foliage effects.
- Low-elevation-angle effects of ASD radar antenna for a range of 5 miles.

Under this contract a Ku-band (14.5 GHz) cooperative beacon transponder was also developed and tested in the laboratory to show the unique feature of a solid-state active target-enhancement technique. Further detailed studies and developments are recommended on the cooperative beacon transponder. These are as follows:

- Perform field tests with an existing ASD (T.I.) radar at Los Angeles International Airport (LAX), California using a modified version of the breadboard cooperative beacon transponder developed under this contract. Additional development and field-test costs are expected to be \$15,000. Compare performance results of the active target-enhancement techniques with those of the passive corner reflectors that exist at LAX. These results would be beneficial for future detection-system studies at the airports.
- Develop a cooperative beacon transponder at 24 GHz similar to the one for Ku-band developed on this contract, that could be used with existing ASDE II (AIL) radars for target-enhancement purposes. There are presently far more ASDE II (AIL) radars around the world than ASD (T.I.) radars.
- Design, develop, and test a low-cost preproduction model of high-sensitivity Ku-band or any other cooperative beacon transponder. Develop a low-cost, high-efficiency miniature power supply that could be used in beacon transponders. Add features for encoding and decoding that could be used in conjunction with discrete-address systems.

- Field-test a low-cost preproduction model of Ku-band or any other cooperative beacon transponder for tracking of personnel, vehicles, and material in a dense-foliage environment over a limited range of 5 miles.

X. FINAL CONCLUSIONS

The results of the investigations performed in Sections II through IX showed that a new class of state-of-the-art solid-state cooperative beacon transponders are practical as target-enhancers for use with certain types of airport surface detection (ASD) or tracking radars. Such beacon transponders also lend themselves to use in physically small, low-cost, low-energy-consuming electronic markers.

In the studies reported here, all the objectives of the program outlined in Section I were satisfied. The following are the main conclusions derived from the investigation:

- Better techniques are needed for detection of small aircraft and vehicles and air traffic control on the ground for Category III conditions as outlined by FAA for future requirements (See Appendix A).
- Based on the review made of the published literature, only three types of ASD radars were found to exist that can be used for surface detection or tracking. These radar are ASD (T.I.) at 16.5 GHz (14.3 GHz exists now), ASDE II (AIL) at 24 GHz, and ASMII (Decca Radar) at 35 GHz.
- Frequencies allocated by FCC for surface detection and air traffic control are 14–14.3 GHz, 24.25–25.25 GHz, and 31.8–33.4 GHz.
- As the rate of rainfall increases, atmospheric propagation losses increase. Maximum rainfall considered in the study was 16 mm/hr.
- Target-enhancement requirements are reduced as the noise figure of the radar receiver is reduced. Lowest target-enhancement requirements, for a given system SNR of 13.8 dB, were for the ASD (T.I.) radar at 16.5 GHz with a receiver noise figure of 4.5 dB. To achieve a range of 5 miles in 16-mm/hr rainfall only 3.3 watts of output power is required from the beacon transponder. For the same operating conditions and receiver noise figure a power output of 12 watts is required from the beacon transponder at 24 GHz when ASDE II (AIL) radar is used.
- The ground clutter and the multipath effects could affect the operation of the ASD radar. To reduce such effects, frequency-discriminating enhancement devices or multiple ASD radars should be used.
- Cooperative-beacon-transponder techniques are desirable and practical for target-enhancement purposes, whereas active or passive reflector techniques are impractical.
- To obtain a low-cost cooperative beacon transponder, hybrid thin-film fabrication techniques should be used. All RF designs recommended in this report could be fabricated using planar techniques, such as MIC or stripline. The low-frequency circuit design could be fabricated using either existing integrated digital logic or hybrid printed-circuit-board techniques.
- A 14.5-GHz cooperative beacon transponder was fabricated using a pulsed low-Q coaxial IMPATT diode oscillator in the transmitter and a diode detector in the receiver. The breadboard

contained features of a low-cost beacon transponder. Measured output power was 2.4 watts (the power output from IMPATT diode oscillator was 4.8 watts at 7% efficiency). The measured receiver sensitivity was -42 dBm.

- Review of the various receiver concepts in the beacon transponder showed that diode detectors can be used for short-range applications (1–2 miles) and mixers pumped with a local oscillator can be used for long range (2–5 miles). Active devices in both the concepts were Schottky-barrier diodes.
- Review of the various transmitter concepts for the beacon transponder showed that a single IMPATT diode or transistor oscillator can be used for low-power applications. Two to three IMPATT diodes or transistor oscillators or amplifiers can be used for medium-power applications, and multiple IMPATT diodes or transistor oscillators or amplifiers can be used for high-power applications. Selection of the active device depends on the frequency of operation.
- Based on the review of the various state-of-the-art receiving and transmitting active devices, the following are some recommendations that were derived for beacon transponder applications:
 - Transmitting Devices: Use IMPATT diodes singly or in combining circuits for frequencies greater than 4 GHz (combining circuits are used for medium- or high-power requirements). Use transistors singly or in combining circuits for frequencies less than 4 GHz (combining circuits are used for medium- or high-power requirements).
 - Receiving Devices: Use Schottky-barrier diodes, bipolar transistors, or field-effect transistors for frequencies less than 8 GHz. Use Schottky-barrier diodes for frequencies greater than 8 GHz.

APPENDIX A

**NEEDS FOR BETTER DETECTION TECHNIQUES
AND AIR TRAFFIC CONTROL ON THE GROUND**

APPENDIX A

NEEDS FOR BETTER DETECTION TECHNIQUES AND AIR TRAFFIC CONTROL ON THE GROUND

A number of ASDE surface-detection radars were installed at about ten major U.S. airports in the early 1960s. No additional installations have been made since then in the United States, but a number of more recent installations employing advanced radar were made at European airports. The current U.S. operational ASDEs are considered obsolete in terms of what can be achieved with today's technology.

The aviation community is making progress toward all-weather landing capability. Improved versions of the ILS system employing solid-state components have been installed at a number of U.S. airports, and category IIIA capability exists at Dulles airport and planned for others. However, the major effort to obtain an improved landing guidance capability has been through developing a satisfactory microwave landing guidance system (MLS). Over a relatively brief period of intensive effort, the RTCA SC117 committee has developed the broad specifications for such a system. Based on these guidelines, the FAA's MLS program is currently at the Phase II level of flight-testing with the prototype equipment of four contractors. Improvements in landing guidance capability is creating the need for better airport surface traffic control. At most of the larger airports, runways may be as much as 2 nmi distance from the tower. Thus it is obvious that even under Category I conditions (200-ft decision height, ½-mile visibility) tower and ground traffic controllers will have difficulty seeing the extremities of the airport and cannot provide an adequate level of guidance to aircraft on the runways and taxiways unless extensively aided by pilot position reports. For Category II and III conditions (lower decision height, less visibility), ground traffic control is even more difficult for controllers and pilots alike when guidance and control is limited to traditional techniques. The recent ground collision at Chicago O'Hare between a taxiing jet and one taking off pointed up the need for better airport surface surveillance tools.

The sophistication of the surveillance and control system required to complement adequately the expected level of increased all-weather operation at major airports will depend upon the traffic level and the demand to conduct such operations. A total system approach is needed to achieve efficient and safe restrictive visibility operations on an airport's runway/taxiing structure; the AGTC study recently awarded by TSC will be addressing many facets of the total problem.

Texas Instruments (T.I.) has been working since the late 1960s on an advanced surface detection radar that T.I. calls the ASD. A prototype system is being tested at LAX airport. The operation of this radar was observed by SRI personnel on 27 November 1973. We noted that although large aircraft in motion could be easily detected, there was considerable clutter on the display, which would appear to make the rapid detection of stationary aircraft and vehicles difficult, if not impossible, unless the display is continuously monitored by a dedicated operator. The boundaries of runways and taxiways were not clear. In order to delineate the boundaries of a high-speed turnoff of RW24R, FAA and airport personnel deployed a number of corner reflectors. These returns, as well as the returns of runway lights associated with RW24R, appeared as large dots on the display comparable in size to what one might expect from a

small aircraft or a vehicle. However, use of corner reflectors is limited for large ranges, as the investigation in this report will show.

We understand that T.I. will incorporate a video mapper as an improvement of the current display. If registered properly, video outlines would practically eliminate the need for corner reflectors or active enhancers to define taxiways, etc. for short ranges. Yet there still may be objectionable clutter within runway/taxiway areas that may be confused with an aircraft or vehicle being controlled, or that could hide a vehicle. Every effort, of course, should be made to repave or condition runway/taxiway areas so that they provide minimum clutter and thus enhance the detectability of targets in these areas.

It is recommended that an active enhancement device should be carried by all ground vehicles permitted to operate on runways and taxiways during restricted visibility conditions. Such targets can be enhanced by the beacon transponder; alternatively, an identity (code) offset from the radar frequency can be obtained from the vehicle. Such a feature would enhance the control of these vehicles.

It is well known that owners and operators of aircraft want to minimize the acquisition of additional "black boxes." However, to engage in Category II and particularly Category III operations, aircraft have to be equipped with highly reliable navigation/autopilot systems, and pilots must be rated for specific aircraft. The design and testing of the Lockheed L-1011 aircraft systems (including power distribution) — navigation and autopilot systems to permit automatic Category IIIA — took some years to demonstrate an acceptable level of operational reliability. The point we wish to make is that Category II and III landings offer serious problems; thus we believe that the equipping of aircraft engaged in such operations with special beacons to enhance detectability and provide identification and enhance automatic control while on the surface of an airport would be a part of the system solution to obtaining all-weather, high-density operations at major hub airports.

APPENDIX B

AIRBORNE BEACON TRANSPONDER

APPENDIX B

AIRBORNE BEACON TRANSPONDER

The specifications of a typical airborne beacon transponder used by commercial airlines is as follows:

- AVQ-95 System Description – Built by RCA

The AVQ-95 ATC Transponder System is a compact, solid-state radar beacon system consisting of three major units: the transponder, the control unit, and the antenna. The AVQ-95 performs the airborne portion of the functions of the Air Traffic Control Secondary Surveillance Radar (ATCSSR) system. The purpose of the ATCSSR is to provide faster, safer, more positive means of air traffic control. Essentially, the AVQ-95 functions as the airborne portion of a two-way communications link; it receives interrogations on one frequency and transmits replies on another. This reply of the transponder serves two basic purposes: it provides a strong, interference-free signal to the ATC ground radar, and it provides a means of conveying specific information about the aircraft itself. These capabilities of the transponder serve to increase the aircraft-handling capacity and precision of the ATC centers in four ways: it allows ATC controllers to quickly locate and identify individual aircraft within their ranges; it reduces the need for voice communication; it eliminates the need for identifying maneuvers by the aircraft; and it extends the coverage of ground radar up to 200 nmi.

The AVQ-95 operates in the L-band of radar frequencies. Primary power supply for the system is the aircraft 27.5-Vdc power source. Its basic purpose could be said to “cooperate” with the ATC ground radar. Normally, a radar detects an aircraft by virtue of skin echoes reflected back to the receiver portion of the radar system. It frequently happens, however, that the desired skin return is either attenuated by distance or lost among the ground clutter on the radar display. The airborne transponder (or radar-beacon) overcomes this problem by first detecting that the aircraft is being scanned by a radar beam, and second, by transmitting a pulsed reply much like an “amplified” return on the radar receiving frequency, which is 60-MHz removed from the interrogation frequency. The radar receives this amplified return just as it would its own echo and displays it as a brighter blip readily distinguished from the other returns. To a radar-beacon such as the AVQ-95, the scan of a radar beam acts as an interrogation to which the AVQ-95 must transmit a reply. It is from this cooperative response transmission that the transponder receives its name. Although this, in simplified form, is the basic purpose of the radar beacon, the modern-day transponder embodies a host of refinements that vastly extend the utility of the radar beacon and that have provided ATC controllers with a much more positive means of traffic control.

The AVQ-95 cooperates with the FAA-operated ATC Radar-Beacon System (RBS) which was specifically developed as a secondary surveillance radar (SSR) system to provide reliable ground control of air traffic by means of radar. The SSR is as much a communications system as it is a radar system. The antenna of the secondary system is frequently mounted on the antenna of the

primary system so that the two antennas rotate in unison. This permits the transponder's amplified returns to be displayed as bright (blooming) blips in the proper azimuth and range relationship with the primary radar display. The AVQ-95, which operates in the L-band radar frequency, receives interrogation from the ATCRBS at 1030 MHz and replies at 1090 MHz. Owing to the high frequencies used, the signals are clear and interference-free. As these signals are a line-of-sight transmission, the further the airplane is from the ground radar, the higher the airplane must be to provide useful communications.

- Performance and Characteristics of the AVQ-95 ATC Transponder

- General

Range: 200 nmi

Operating altitude: up to 45,000 ft

Solid-state design: only one tube

Power requirements: 1.25 A at 27.5 Vdc (nominal)

Reply-pulse-spacing tolerance: 0.1 μ s, measured from first pulse to any other pulse in the reply group

Interrogation Modes: mode spacings chosen from 8 μ s (Mode A) and 21 μ s (Mode C)

Sidelobe suppression: 3-pulse

FAA TSO: C74b, CAT. AAJAAAEXXXXX Class 1

FCC type acceptance

System weight: 7.5 pounds

- Receiver/Transmitter

Transmitter power output: 400 W

Transmitter frequency stability: \pm 2.5 MHz

Transmitter frequency: 1090 MHz

Transmitter frequency control: cavity oscillator

Receiver sensitivity: -74 dBm

Receiver selectivity: less than 3 dB attenuation at \pm 3.0 MHz; greater than 60 dB attenuation at \pm 25 MHz and beyond

Receiver frequency stability: \pm 100 kHz

Receiver frequency: centered at 1030 MHz

Receiver frequency control: crystal controlled

Overall delay: 3.0 \pm 0.5 μ s

Number of reply codes: 4096 pilot-selected codes, expandable to 8192 on Mode A; Mode C automatic altitude reporting from -1000 ft to 126,750 ft

Self-test: both Modes A and A/C

Interrogation modes: A & C (in keeping with new FAA ATC system planning)

Size: dwarf short 3/8 ATR

Mounting: hard mounting on 0.45-pound tray

Weight: 6.3 pounds

- Control Panel

Code Indication: 4-digit readout

Controls: IDENT; modes A, A/C, STBY, OFF; TEST, MONitor, DIM; interrogation reply light; thumbwheel code selectros; optical dual system transfer switch

Illumination: 5 Vac or dc aviation white

Panel Colors: gray or black

Size: 2-7/16" X 2-7/8" X 2-3/4"

Weight: 0.45 pound

— Antenna

L-band blade-type antenna suitable for DME or transponder

Weight: 0.3 pound.

From the above description of RCA's AVQ-95, it can be concluded that present ATC transponders are required to perform more than their one main basic function — i.e., target enhancement. As a result, the designs are complex and costs are high. Therefore designs of ATC transponders and ASD transponders should not be compared on a one-to-one basis. They may have similarities in the basic concept and system techniques, but present requirements for ASD beacon transponders for a distance of five miles are not nearly as complex. Further system studies on airport surveillance detection are necessary to determine whether sidelobe-suppression techniques have to be incorporated in the ASD beacon transponder or in the ground radar. Such studies are beyond the scope of this project and should be considered for follow-up programs.

APPENDIX C

CHARACTERISTICS OF TEXAS INSTRUMENTS ASD RADAR

APPENDIX C

CHARACTERISTICS OF TEXAS INSTRUMENTS ASD RADAR

The characteristics of the T.I. ASD radar that is installed at Los Angeles International are shown in Table C-1. The T.I. ASD characteristics considered for this study were somewhat different, and all the theoretical work was done at 16.5 GHz. However, few of the previous conclusions are affected, primarily because all the operational specifications of the ASD radar are essentially the same. By decreasing the frequency to 14.1 GHz, less atmospheric attenuation exists and therefore target-enhancement problems are reduced.

Table C-1. Characteristics of Texas Instruments ASD Radar at LAX

| | Functional | Measured at LAX Airport |
|---------------------|----------------|------------------------------------|
| Transmitter | | |
| Frequency | 14.1–14.3 GHz | Ch A 14.167 GHz Ch B 14.045 GHz |
| Pulsewidth | 35 ns ±5 ns | Ch A 31 ns Ch B 34 ns |
| Average power | | Ch A 12.5 W Ch B 13.1 W |
| Peak power | 24 kW min | Ch A 27 kW Ch B 28 kW |
| PRF | 15 ± 0.5 kHz | Ch A 15.1 kHz Ch B 14.9 kHz |
| Receiver | | |
| IF center frequency | 60 MHz | |
| Sensitivity | -85 dBm | Ch A -96 dBm Ch B -92 dBm |
| Bandwidth | 30 MHz | Ch A 42 MHz Ch B 55 MHz |
| Noise figure | 11 dB max | |
| Dynamic range | | Ch A 32.3 dB Ch B 30.6 dB |
| Antenna | | |
| Scan rate | 150 rpm ± 20 | |
| Tilt | 0° to -3° | 0° |
| VSWR | | |
| Bandwidth | | |
| Horizontal | 0.3° | |
| Vertical | 10° | |
| Gain | 33 dB | |

| REPORT DOCUMENTATION PAGE | | READ INSTRUCTIONS BEFORE COMPLETING FORM | |
|--|---|--|-----------------------------|
| 1. REPORT NUMBER | 2. GOVT ACCESSION NO. | 3. RECIPIENT'S CATALOG NUMBER | |
| 4. TITLE (and Subtitle) DIODE BEACON TECHNIQUES | | 5. TYPE OF REPORT & PERIOD COVERED Final Report 31 May 1972 to 30 September 1973 | |
| 7. AUTHOR(s) Ashok K. Gorwara | | 6. PERFORMING ORG. REPORT NUMBER SRI Project 1970 | |
| 9. PERFORMING ORGANIZATION NAME AND ADDRESS Stanford Research Institute Menlo Park, California 94025 | | 8. CONTRACT OR GRANT NUMBER(s) Contract F30602-72-C-0444 | |
| 11. CONTROLLING OFFICE NAME AND ADDRESS Rome Air Development Center Griffiss Air Force Base Rome, New York 13440 | | 10. PROGRAM ELEMENT, PROJECT, TASK AREA & WORK UNIT NUMBERS | |
| 14. MONITORING AGENCY NAME & ADDRESS (if diff. from Controlling Office) | | 12. REPORT DATE January 1974 | 13. NO. OF PAGES 158 |
| | | 15. SECURITY CLASS. (of this report) Unclassified | |
| | | 15a. DECLASSIFICATION/DOWNGRADING SCHEDULE | |
| 16. DISTRIBUTION STATEMENT (of this report) | | | |
| 17. DISTRIBUTION STATEMENT (of the abstract entered in Block 20, if different from report) | | | |
| 18. SUPPLEMENTARY NOTES | | | |
| 19. KEY WORDS (Continue on reverse side if necessary and identify by block number) | | | |
| Air traffic control | Target-enhancement techniques | Receiver concepts | |
| Cooperative beacon transponder | Clutter and multipath propagation effects | Transmitter concepts | |
| Beacon transponders | IMPATT diode oscillator | Markers -- electronic | |
| Transponders | Microwave power-combining techniques | | |
| Airport surface detection radars | Solid-state devices | | |
| 20. ABSTRACT (Continue on reverse side if necessary and identify by block number) | | | |
| <p>In recent years, there has been a great interest in physically small, low-cost, low-energy-consuming electronic markers for tagging materials and vehicles, for air traffic control on the ground, and for surveillance or tracking of personnel over a limited area. The purpose of the study reported here was to investigate the state of the art in low-cost beacon components that will provide a target-like signal for a maximum range of 5 miles in various weather conditions when they are illuminated by search, tracking, or surface-detection radars. Although cooperative beacon transponders are, in general, used for operational functions such as IFF (identification, friend or foe), airborne traffic control, and weapon control and delivery systems, the requirements and frequency of operation for ground-controlled electronic markers are different. In this study, new approaches to providing beacon signals</p> | | | |

19. KEY WORDS (Continued)

20 ABSTRACT (Continued)

using state-of-the art devices and circuit techniques were investigated.

The characteristics and specifications of the only three existing types of airport surface detection (ASD) radars, operating at 16.5 GHz (14.3 GHz for a later model), 24 GHz, and 35 GHz, were investigated for use with the three types of target-enhancement techniques — namely, passive reflectors, active reflectors, and cooperative beacon transponders. Target-enhancement requirements were evaluated for these techniques at various ranges up to a maximum of 5 miles for different weather conditions.

General ground clutter and multipath propagation effects on the operation of ASD radars were reviewed briefly and a few procedures were suggested for reduction of the effects.

Performance specifications of the cooperative beacon transponder operating at a range up to 5 miles were determined for the 16.5 GHz, 24 GHz, and 35 GHz frequency bands. General design goals, frequency-independent design techniques, and design concepts were investigated in detail for low-cost, low-energy-consuming and efficient, instantaneous or delay-type cooperative beacon transponders.

A 14.5-GHz solid-state cooperative beacon transponder was designed, fabricated, and tested. Low-cost digital logic techniques were used instead of analog techniques for isolation of receiver and transmitter, and for signal processing. A pulsed, low-Q, coaxial IMPATT diode oscillator was used in the transmitter, and a diode detector was used in the receiver. The power output measured from the IMPATT diode oscillator was 4.8 watts peak, the duty cycle was 0.7%, the pulsewidth was 450 ns, and the dc-to-RF efficiency was 7%. Output power measured from the beacon transponder was 2.4 watts and the minimum detectable signal at the receiver was -42 dBm.

The performance and capability of state of the art active devices were investigated over a wide frequency spectrum. The devices were IMPATT, TRAPATT, Gunn, LSA, p-n junction, point contact, and Schottky-barrier diodes, and bipolar and field-effect transistors.

Different nonoptical and quasi-optical power-combining techniques for oscillators and amplifiers using either direct-generating devices or transistors were investigated for application in medium- or high-power beacon transponders.

Finally, production costs were estimated for small and large quantities of a particular type of beacon transponder operating at 14.5 GHz and 24 GHz.